

# ANTON

## *Sprint* v2

**Multi-function flue gas analyser**



# User Manual





























**M09999**

July 2006  
Issue 1

**TELEGAN**  
gas monitoring



## Summary of Screen Icons

	Select, pick or action
	Up item or entry
	Down item or entry
	Left field
	Right field
	Zero pressure
	Start (Pressure & CO Room Safety tests)
	Stop (Pressure & CO Room Safety tests)
	Restart (Pressure & CO room tests)
	Yes, pass or done
	No or fail or cancel
	Purge icon
	Hold / pause readings
	Select temp 1 (flow) (Differential Temperature test)
	Select temp 2 (return) (Differential Temperature test)
	Save log
	Print
	Send XML report to Bluetooth
	Serial communications with PC in progress – please wait
	Delete
	Darker contrast
	Lighter contrast
	Restore default contrast
	Edit value
	Increment value
	Decrement value
	Decrement through character list (String edit)
	Increment through character list (String edit)

## Safety information:

- Read and understand all instructions in the operation section of this manual before use.
- Do not substitute components as this may impair safety and invalidate warranty.
- Observe all warnings and instructions marked on the unit and within this manual.
- If this product is not working properly, read the troubleshooting guide or call Anton.
- Ensure qualified service personnel change sensors and provide maintenance and calibration.

## Additional information:

Sprint is designed to support the working practices defined in British Standard BS7967 and the Design Standards EN50379, BS7927 for flue gas analysers. It is highly recommended that users are fully conversant with BS7967 when using a flue gas analyser for servicing or installing a boiler system.

Sprint offers a timed let-by/tightness test in accordance with the UK's Institute of Gas Engineers' procedure IGE/11/UP/1B.

## Performing CO measurements

When performing any CO measurements **ensure the unit is zeroed in clean air** in accordance with British Standard BS7967. A suitable location for sampling clean air will be outside of the building where the boiler system is installed.

1. Repair of this equipment and gas sensor replacement shall be carried out by the manufacturer or certified service centre in accordance with the applicable code of practice.
2. If the equipment is likely to come into contact with aggressive substances, then it is the responsibility of the user to take suitable precautions that prevent it from being adversely affected.
3. The equipment is only certified for use in ambient temperatures in the range -10°C to +50°C and should not be used outside this range
4. Use only charger(s) supplied by Telegan/Anton.
5. Use only the appropriate Telegan/Anton supplied cables for connection to the sockets on the instrument.

---

# Contents

---

Sprint V2 Multi-function Flue Gas Analyser .....	2
Unpacking.....	2
Overview.....	3
Probe connections.....	4
Quickstart Guide.....	5
I. Operation .....	13
1.1 Menu and operator button overview .....	13
II. Setting Up .....	15
2.1 Configuration Options .....	15
III. Battery Charging .....	17
Charging the batteries.....	17
IV. Maintenance and calibration .....	18
4.1 Unit.....	18
4.2 Water trap.....	18
V. Specification .....	19
X. Accessories and spare parts .....	21
VI. Logging .....	22
VII. Printing.....	23
VIII. Troubleshooting guide.....	24
Appendix I: Carbon Monoxide Room Safety Tests .....	26

---

# Sprint V2

## Multi-function Flue Gas Analyser

---

Thank you for purchasing the *Sprint V2 Multi-function Flue Gas Analyser*. Sprint has redefined flue gas analysis and will give you years of unparalleled service and reliability.

Please read the instructions carefully before use. Keep the manual for future reference.

### Unpacking

**Important: ensure unit is fully charged.**

Remove the Sprint unit from the packaging. The Sprint accessories will be located in the carry case. Check the contents are complete, you should have:

- Carry case;
- Sprint unit;
- Mains battery charger power supply;
- Rubber boot;
- Flue probe, including water trap;
- A5 user guide;
- User manual on CD;
- Certificate of calibration;
- 2 x 1 m tubes for pressure (Natural gas or LPG).

Options to include:

- Gas leak probe;
- Additional thermocouple probes;
- In-car charger;
- Infra red printer.

#### **Warning:**

Do not attempt to use any other charger power supply, with this unit except the one(s) supplied. Failure to comply could invalidate the warranty and may result in permanent damage to the unit.

# Overview

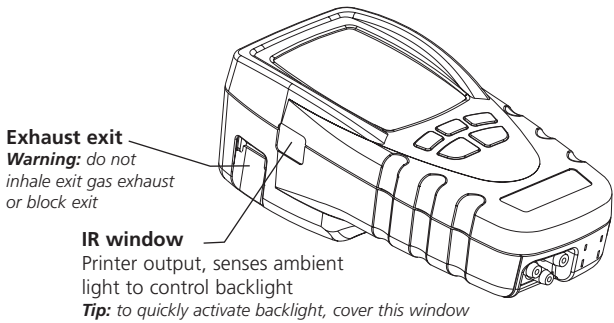
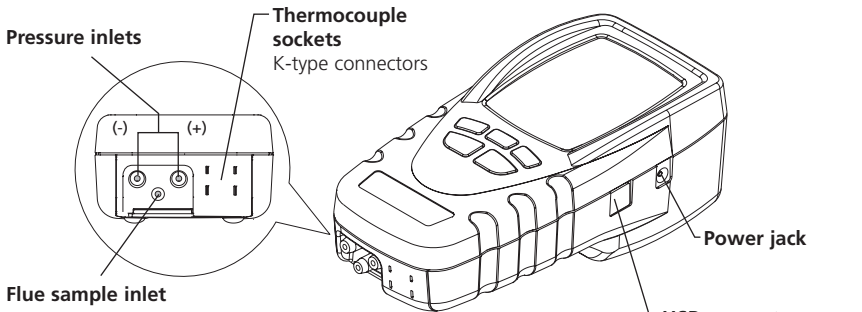
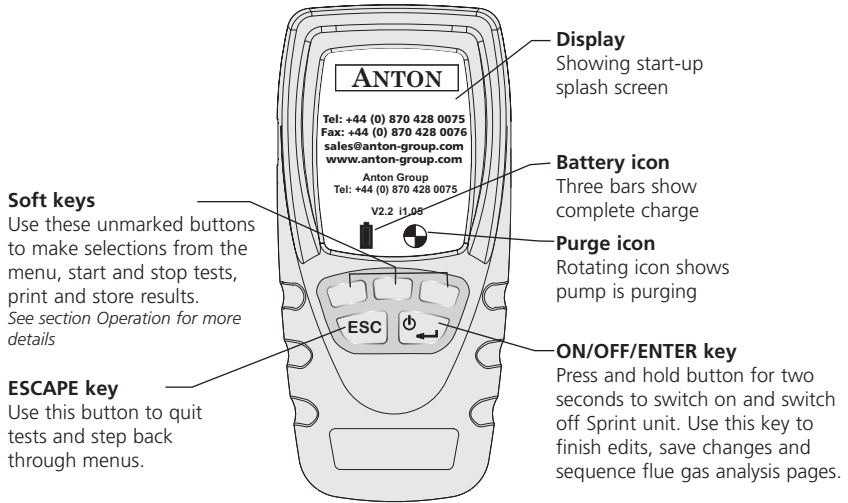

## Probe connections

**Tip:** see label underneath unit for details of probe connections

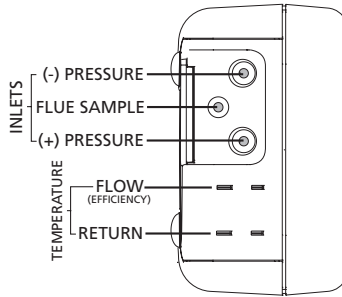

### Flue gas analysis

Connect the flue probe to the flue sample inlet and the thermocouple to the k-connector marked FLOW (Efficiency).

### Differential pressure, let-by and tightness test

Connect tubing to pressure inlet(s). Sprint will display a warning if the tubes are connected incorrectly.

### Differential temperature test

Connect one or two thermocouple probes to the k-type connectors. When using one probe, Sprint will display a soft key option to switch between T1 and T2 snapshot measuring points.

### Room CO safety test

Connect CO room safety test probe (optional), where suitable, to the flue sample inlet.

### Gas escape test

Connect gas leak probe to the USB connector.

*Note:* The pump will operate at different speeds or switch off depending on the test being performed. This will vary the pitch of the sound from the pump and does not indicate the pump is performing incorrectly.

## Accessories

Sprint is supplied with a rubber boot for protection of your Sprint unit. A magnet on the reverse of the rubber boot can be used to place the Sprint unit in location on the boiler system for easy hands-free operation.

# Quickstart Guide

## Switch On

**Important: please connect flue probe first before switching on your Sprint unit, ensure the water trap is empty and is fitted in the right direction. Do not insert probe in flue till after auto zero. Always start in clean air.**

Press and hold the ON/OFF/ENTER key for two seconds. Sprint will emit a few rising beeps, performs a screen test and starts the pump to purge any residual gas from the unit. Ensure the gas exhaust outlet is not blocked.

The welcoming splash screen is displayed for approximately 30 seconds and will automatically go to the Auto zero screen. When Auto zero is complete the display will change to the *Test* menu. Warm-up should be extended if sensor needs to recover from previous gas exposure.

**Tip:** see soft key icon list on the inside front cover of this manual

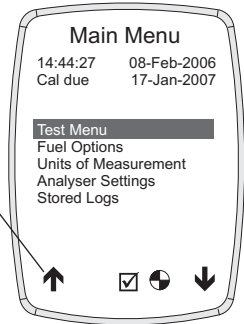

## Auto zero

When Sprint has completed warm-up the auto zero screen will be displayed. **Ensure you are in clean air before proceeding.**

**Tip:** auto zero Sprint outside of the building or well away from the heating appliance to avoid any potential gases in the vicinity affecting the auto zero process.

Ensure the sensor reading is stable, press the proceed ✓ key to begin auto zero. After a successful auto zero Sprint will display the *Test* menu screen and switch off the pump.

*Note: Sprint will switch off the pump when not performing tests or purging.*

**Tip:** check sensor reading is stable. Otherwise Sprint will display 'Not stable' and arrow will tilt up or down

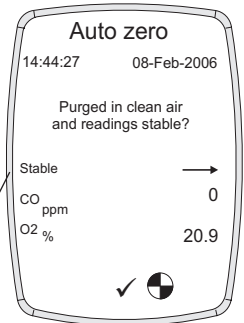

## Using the menu

Press the ESC key to display the *Main* menu. Use the soft keys to scroll, select and edit menu items (see icon list - inside front cover). Press accept  to make change or the ESC key to cancel. Press the ESC key to return to the *Main* menu.

### Changing fuel, units and efficiency options

From the *Main* menu select *Fuel Options* or *Units of Measurement*.

*Fuel Options*: select one of the following options: natural gas, LPG, heavy oil, light oil, coal, wood, coke, Biomass and BAGASSE.

*Units of Measurement*: select one of the following options:

*Pressure units*: mbar, Pa, hPa, kPa, PSI, inWG, mmWG, inHG or mmHG

*Temperature scale*: Centigrade or Fahrenheit

*Efficiency*: Net or Gross (Net efficiency may be used for condensing boilers)

See section II. *Setting up* for more details.

### Changing display and key pad settings

From the *Main* menu select *Analyser Settings* and one of the following options:

*Display contrast*: use the soft keys to adjust the contrast level.

*Auto off timeout*: use the soft keys to adjust or disable the timeout period.

*Back light*: use the soft keys to select one of the following options: off, dim, bright or controlled.

*Key click*: use the soft keys to enable or disable audible key click.

### Changing date & time, report header and password

From the *Main* menu select *Analyser Settings*>*Supervisor settings*: (if the password has been set, enter the password now) select one of the following options:

*Set date & time*: use the soft keys – and + to change units of date and time and → to select hours, minutes, day, month and year. Press ESC to save.

*Edit report header*: use the soft keys ↑ and ↓ to select header text one or two and ± to edit text. Use the ⏪ and ⏩ keys to scroll through character lists and character values. Press → to move on to the next letter in the header text. Press ON/OFF/ENTER to delete all characters to the right. Press → to move the cursor to the end of the text and  to accept change and return to Edit report header screen. Press ESC to exit edit without saving changes.

*Change password:* press the soft key **±** to edit password. Use the **qz** and **qz** keys to scroll through character lists and character values. Press **→** to move on to the next letter in the password. Press **→** to move the cursor to the end of the text and **☑** to accept change and return to Password screen. Press ENTER to store the change.

## Retrieving stored logs

From the *Main* menu select *Stored logs* and one of the following options:

*Select a log:* use the soft keys to scroll and select log.

*Find a log by number:* use the soft keys to scroll up and down the numbered logs database.

*Delete all logs:* this option will delete all stored logs. Press accept **☑** 'Are you sure?' to clear logs or press ESC to cancel.

## Switch off

Turn off unit in clean air and ensure any gas is purged from sensors. Press and hold the ON/OFF/ENTER button for approximately two seconds. The power off screen will be displayed and the pump will run to purge the sensors. The pump will run for up to 30 seconds to purge unit if gas is present. Sprint will normally switch off in 10 seconds. Press the ESC key to cancel the switch off sequence.

## Charging battery

Plug the supplied charger into the charger socket. The batteries will recharge in six hours from flat. You may leave the unit on charge for longer periods, e.g. overnight, without damaging the unit. A fully charged unit will give up to nine hours of operation. A shorter charge time can be applied, such as 1/2 hour, to allow a more limited length of operation.

# Performing tests

From the *Main* menu select *Test Menu*. Refer to section III *Operation* for more details.

**Warning:** During testing, ensure the combined filter and water trap is not blocked or full. Failure to do so may result in an error message.

## 1. Flue gas analysis

Before performing the flue gas analysis test, check the water trap is clean and is upright (arrow should point upwards). To begin test, select *Flue gas analysis* from the *Test* menu. Sprint will switch on the pump and begin making measurements. Check the fuel type displayed on the screen is correct. Use the soft keys to log or print the results.

Press the ON/OFF/ENTER button to display the three screens available:

Screen 1: CO, CO2, CO/CO2 ratio and pressure.

Screen 2: O2, excess air, temperature and efficiency.

Screen 3 combines both screen 1 and screen 2.

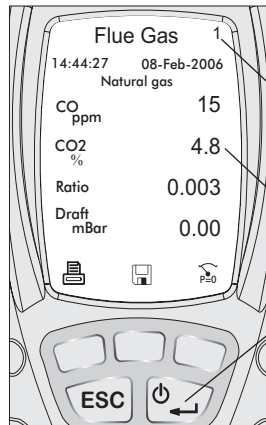

**Tip:** The screen number is displayed here.

**Tip:** If # symbol is displayed - flue probe is not in flue or not connected.

**Tip:** Press the ON/OFF/ENTER button to cycle through the screens.

To perform a pressure zero, use the soft key marked P<sub>0</sub>

To end test press the ESC key.

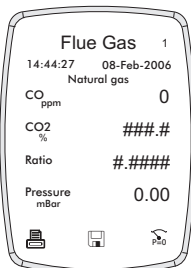

Screen 1

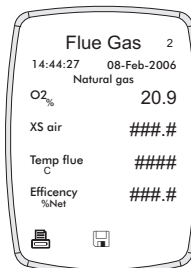

Screen 2

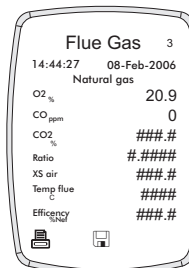

Screen 3

*Note: for personal safety a carbon monoxide alarm will activate at 90ppm CO. This will deactivate when CO levels drop below 45ppm. This is to protect the user from potential hazardous exhaust gas levels.*

## 2. Let-by and Tightness test

### Let-by test

Before carrying out the test, the pressure must be zeroed with the tube connected to the instrument but not the pressure source. Note: in these tests 'Diff press' is the difference between start and finish pressures.

1. Select *Pressure Menu* from the *Test* menu. From the *Press* menu select *Let-by / Tightness*.
2. Connect tube to positive pressure inlet but not pressure source.
3. Zero pressure, use the soft key marked  $\overline{p_{50}}$ .
4. Connect tube to pressure source to begin pressure test. Sprint will give a warning if the pressure points are the wrong way round.
5. Press the soft key  $\blacktriangleright$  to start test. Sprint displays the duration time on the screen.
6. To stop test press the soft key  $\blacksquare$ .
7. Press the soft key  $\checkmark$  to pass test and proceed to Tightness test. You may fail the test by pressing the key  $\times$  to indicate test has failed (you can print the results).

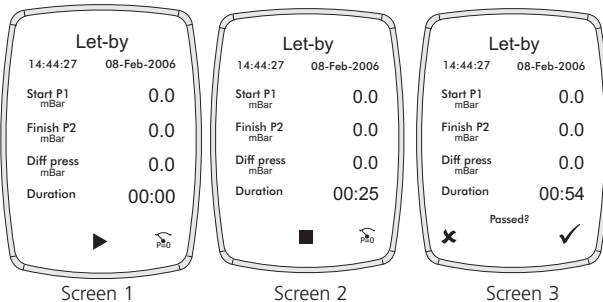

### Tightness Test

1. Connect tube to positive pressure inlet but not pressure source.
2. Zero pressure, use the soft key marked  $\overline{p_{50}}$ .
3. Connect tube to pressure source to begin pressure test. Sprint will give a warning if the pressure points are the wrong way round.
4. Press the soft key  $\blacktriangleright$  to start test. Sprint displays the duration time on the screen.
5. To stop test press the soft key  $\blacksquare$ .
6. Press the soft key  $\checkmark$  to pass test. You may fail the test by pressing the key  $\times$  to indicate test has failed.

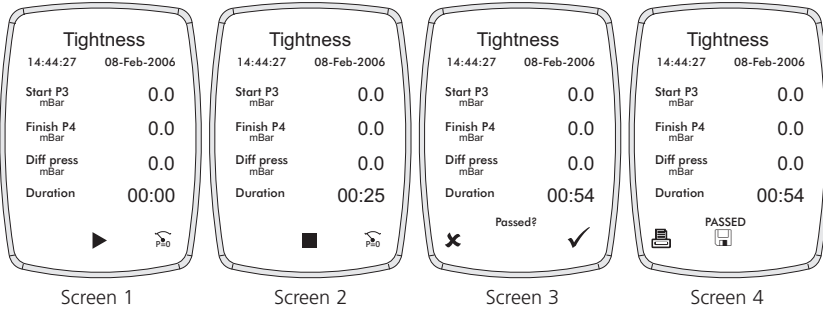

At the end of the tightness test you can log or print the results. Press the ESC key to return to *Press* menu.

Press ESC again to return to *Test* menu.

### 3. Pressure and Differential pressure tests

Before carrying out the test the pressure must be zeroed with the tubes connected to the instrument but not the pressure source. A thermocouple may be connected to provide temperature readings in these tests.

1. Select *Pressure Menu* from the *Test* menu. From the *Press* menu select *Pressure* or *Diff Pressure*.
2. Connect tube(s) to pressure inlet(s).
3. Zero pressure, use the soft key marked  $\overset{p50}{\curvearrowright}$ .
4. Connect tube(s) to pressure source(s) to begin pressure test. Sprint will give a warning if the pressure points are the wrong way round.
5. There is an option to time this test, Sprint displays the duration time on the screen. Press the soft key  $\blacktriangleright$  to start test and timer.
6. To stop timed test press the soft key  $\blacksquare$ .
7. To restart test press the soft key  $\lll$ .  
To re-zero the unit, press  $\overset{p50}{\curvearrowright}$ .

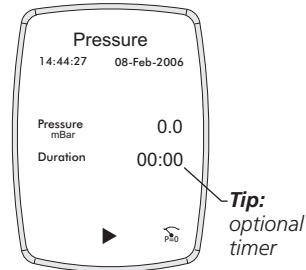

Press the ESC key to return to the *Press* menu screen. To perform the Differential Pressure test repeat steps 2 to 7 above.

Press ESC to return to the *Test* menu.

## 4. Differential temperature test

Sprint can perform a differential temperature test with one or two thermocouple probes. To begin test, select *Diff Temperature* from the *Test* menu. Check the units displayed are the correct temperature scale. If no probes are connected Sprint will display #####.

### Two probe test



Connect both probes to the k-type connectors. See label on back of unit for FLOW and RETURN. Place probes in position. The screen will display the temperature of probe 1 and probe 2, and the differential temperature.

Use the soft keys to log or print the results.

To end test press the ESC key.

### Single probe test

When only a single probe is available, Sprint will display an additional icon on the screen to represent the first and second reading.

1. Place probe in position to make measurement T1.
2. Press the soft key icon  to take a snapshot reading of T1. (Do not remove probe until this snapshot is taken.)
3. Move the probe into position to take second reading T2. The screen will display the icon  to show temperature reading T2 is being taken.  
The screen will display the snapshot temperature, the live probe temperature, and the differential temperature.

Use the soft keys to log or print the results.

To end test press the ESC key.

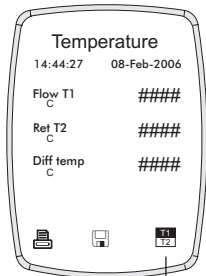

**Tip:** these icons will appear when only one probe is available.

## 5. Room CO safety test

**Ensure the unit has been zeroed in clean air during switch on before performing this test.**

**Note:** For further details on performing Room CO Safety Tests, see Appendix I.

1. Select *CO Room safety* from the *Test* menu. Sprint will display the *Appliance* menu. Select the appliance from the list.  
The appliance will be displayed on the screen during the room CO safety test.

2. Connect probe if required to the Sprint unit and place at the recommended height. Refer to British Standard BS7967 if necessary.
3. The pump will switch on in readiness for test. **NB.** The sound of the pump operating does not indicate the test has begun. Press the ▶ soft key to start test. During the test the screen will display the CO reading, peak CO reading, duration of test and maximum allowed CO for the test.

The test will run for the required duration by appliance according to BS7967. Sprint will emit an alarm if 30ppm (or 90ppm) threshold is exceeded. Sprint is programmed with pass/fail criteria for this test. Refer to British Standard BS7967 for further details on performing room CO safety tests.

Once test can be complete press ■ soft key to finish.

To stop test at any time, press the ESC key. Use the soft keys ✓ or ✕ to select 'Quit test?'. Use the soft keys to log or print the results.

When printing Room CO safety test results Sprint will also provide data showing for how long the recommended level of CO was exceeded. This is expressed as hh:mm > allowed.

## 6. Gas escape test

*Note: Battery power will be used at a higher rate under this test.*

Select *Gas escape* from the *Test* menu. Connect the Gas leak probe to the USB connector, the light will illuminate on the probe. Sprint will display a warning if the probe is not connected.

Sprint will display 'sensor stabilising' for approximately 30 seconds. When the sensor is stable the unit will ask 'in clean air?' before zeroing. Press ✓ to zero the unit. Sprint will display a bar graph on the screen as gas levels are monitored.

Place the probe in the area of inspection for several seconds before moving it to other locations.

Sprint will emit continuous clicks like a Geiger counter. If higher gas levels are detected the bar graph will increase in readings and the sounder will increase in pitch.

Press ESC to quit the test.

# I. Operation

Before using the Sprint flue gas analyser on any heating appliance installation, ensure you are familiar with the working practices defined in the BS7967 which details how to perform certain tests and safety issues to consider.

## *Auto zero setting*

Allow the Sprint unit to auto zero during switch on in clean air before performing any of the following tests: flue gas analysis and room CO safety test. Ensure all tubes and probes are connected before switch on and zero outside in clean air.

## *Pump*

Sprint runs the internal pump during purge at switch on and switch off, and during some tests. A rotating purge icon will appear on the screen  when purging. The speed and therefore the sound emitted by the pump, will vary depending on the test being conducted. To save on the battery life, Sprint will turn off the pump when it is not required.

When the pump is running ensure the exit gas exhaust is not blocked and do not breath in the exhaust gases.

## 1.1 Menu and operator button overview

Sprint provides a large graphic LCD with blue backlight. Navigation and functions are provided by three soft key buttons which change according to what you are doing.

Use the soft keys to navigate menus, select, start and end tests, change options and select actions. such as print, log or zero

Use the escape key to exit menus, exit tests and step back through screens

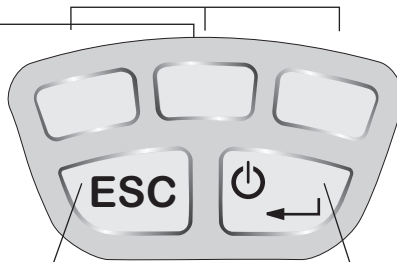

ON/OFF/ENTER switch and Flue gas step through screen

After your Sprint unit has been switched on and performed an auto zero the display will show the *Test* menu screen ready for use. To display the *Main* menu press the ESC key.

To enter a menu item, use the soft keys below the  $\uparrow$  and  $\downarrow$  screen icons to scroll the menu list and press the soft key underneath the  $\square$  screen icon to select. Some menus have their own submenu.

Press the ESC key to exit a menu, press ESC twice to return to the *Main* menu from a submenu.

The soft keys control the function displayed above them on the screen. These will change depending on the test or menu, or if the ESC key is pressed.

The menu structure is shown below:

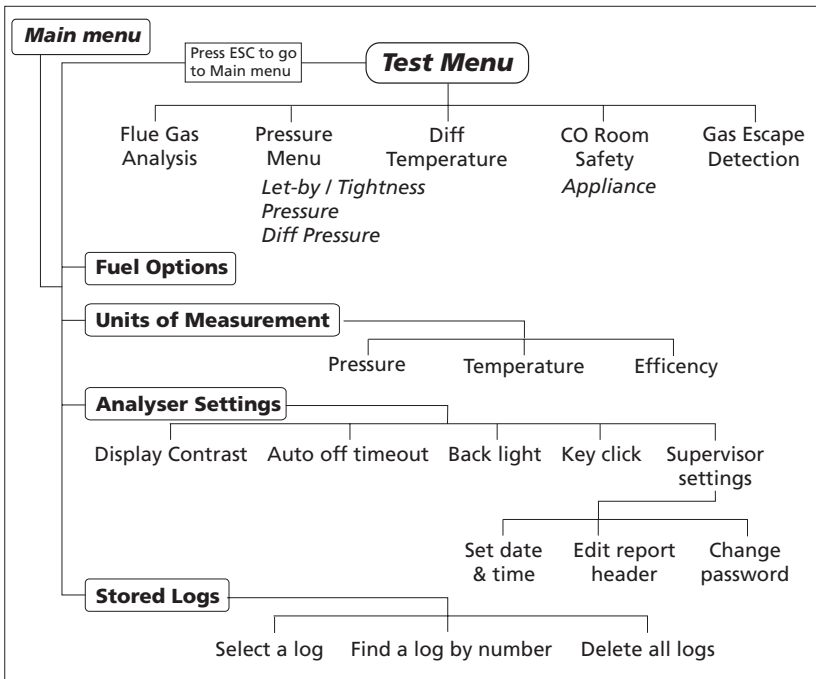

## How to display unit serial number, identity and software version

Press the ESC key from the *Main* menu

---

## II. Setting Up

---

### 2.1 Configuration Options

#### **Fuel Options:**

Sprint displays the current fuel option on the screen. To change the fuel option press the ESC key to enter the *Main* menu and select *Fuel Options*. Use the soft keys to scroll and select the desired fuel using ✓. The new fuel option will be displayed on the test screens.

Fuel options available are: natural gas, LPG, heavy oil, light oil, coal, wood, coke, Biomass and BAGASSE.

#### **Units of measurement:**

To change the units of pressure, temperature or efficiency press the ESC key to enter the *Main* menu and select *Units of Measurement*. Use the soft keys to select the submenu and units for *Pressure*, *Temperature* or *Efficiency*.

Temperature units are: degrees Celsius (°C) or degrees Fahrenheit (°F).

Pressure units are: mBar, Pa, hPa, kPa, PSI, inWG, mmWG, inHG and mmHG.

Efficiency units are: Net or Gross

#### **Analyser settings:**

The Analyser settings menu allows you to alter the settings for the display, auto off timeout, back light, key pad and Supervisor settings. To change any of these settings press the ESC key to enter the *Main* menu and select *Analyser Settings*. Use the soft keys to select the submenus.

#### **Display contrast**

On the display contrast screen a bar graph is displayed showing the level of contrast. Use the soft keys < and > to reduce or increase the level of contrast. Press the  key to accept the change or ESC to cancel.

#### **Auto off timeout**

On the auto off timeout screen the number of minutes at which the unit will automatically switch off is shown. Use the soft keys – and + to reduce or increase the number of minutes. Press the  key to accept the change or ESC to cancel. To disable Auto off timeout press – key until 'disabled' is displayed.

#### **Back light**

The back light can be set to four options: off, dim, bright or controlled. Use the soft keys to scroll and select the option desired. Press the  key to accept the change or ESC to cancel.

Back light options are:

*Off*: switches the backlight off

*Dim*: lowers the light intensity

*Bright*: increases the light intensity

*Controlled*: Sprint monitors the ambient light level and adjusts the light intensity accordingly.

### Key click

The Key click settings allows you to enable or disable the key pad from making audible 'clicks' when pressed. Use the soft keys to select 'enabled' or 'disabled' from the submenu. Press the  key to accept the change or ESC to cancel.

### Supervisor settings

#### Set date & time

On the Time & Date screen the current time and date are shown. Use the soft keys – and + to alter the values of hours, minutes, day, month and year. Use the → key to select each unit. Press the ESC key to accept the change.

#### Edit report header

Use the soft keys ↑ and ↓ to select the report header text line one or two. Press  key to edit text. The screen displays the character lists and highlights the current list in use. Use the ⏪ and ⏩ keys to scroll through character values in each list and → to move on to the next letter in the header text. The character lists are shown below.

Press ON/OFF/ENTER to delete characters to the right. Press → to move the cursor to the end of the text and  to accept change and return to Edit report header screen.

#### Change password

Press the soft key  to edit password. Use the ⏪ and ⏩ keys to edit or create a password as described above in *Edit report header*. Press  to accept change and return to Password screen. Press ON/OFF/ENTER to store the change.

When a password has been created, Sprint will display the Supervisor password screen on entering *Supervisor settings*.

! .. /	!"#\$%&'()*+,-_ /
0 .. 9	0123456789
:.. @	: ; < = > ? @
A .. Z	Uppercase alphabet
a .. z	Lowercase alphabet
Space	

---

## III. Battery Charging

---

The Sprint has a lithium-ion rechargeable battery and will operate for up to 9 hours when fully charged, depending on the type of test used.

### Low battery

When the battery is low, Sprint will display a low battery icon. If the battery gets too low, then Sprint will give further warning before switching off.

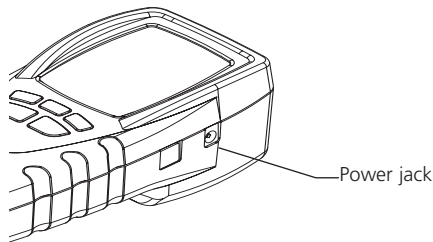

### Use of the charger as a power adaptor

The Sprint charger can be used to power the unit and will continue to charge whilst operating the unit.

### Automatic battery saver

The Sprint unit will automatically power down if left unused (unless *Auto off* disabled). The auto off timeout can be set in *Analyser settings*.

## Charging the batteries

### **Warning:**

*Do not attempt to use any other charger with this unit except the one(s) supplied. Failure to comply could invalidate the warranty and may result in permanent damage to the unit.*

1. Plug the charger into a mains socket.
2. Connect the charger to the Sprint using the power jack on the side of the unit.

Switch on the power at the mains socket. The unit would normally be left switched off for charging. The display will show the battery charging/mains connection icon. When the battery is full both icons will flash.

## IV. Maintenance and calibration

### General

To keep the display panel and operator buttons free from dirt build-up, regularly wipe over your Sprint unit with a slightly damp cloth.

### Protective boot

To protect Sprint from dirt and knocks a rubber boot is supplied. This boot is supplied with concealed magnetics in the rear.

### 4.1 Unit

The Sprint should be calibrated once a year. Your Sprint unit will also display the calibration due date at switch on and will warn you when calibration due date is drawing near. If the calibration due date has passed, the Sprint unit will display a message 'Calibration overdue'.

### 4.2 Water trap

The combined filter and watertrap is used in-line between the probe and the unit. Before performing any tests, check that the filter is clean and there is no water inside the trap.

#### Filter

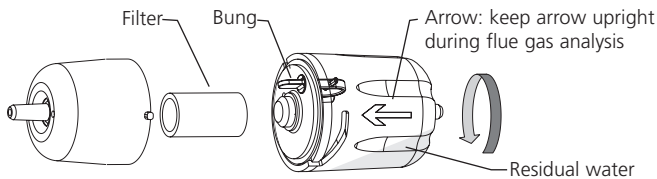

The filter element should be changed if the filter has become contaminated or dirty. If the filter has become soaked with water, remove from trap and leave to dry before reusing. Ensure 'O' ring remains in place.

**Warning:** Filters must be used at all times. Failure to do so may invalidate the warranty.

#### To change the filter

Unscrew the filter-housing, remove the old filter and replace.

#### Water

To empty the water trap, unscrew the filter-housing, remove the bung and empty. Replace bung after emptying.

## V. Specification

### Instrument

Operating temperature range	-10°C to 50°C (14°F to 122°F)
Battery	Lithium-Ion. Life up to 9 hours dependant on test used. 15% left warning.
Recharge time	Minimum 6 hours from flat.
Charger input voltage	230 V; 50 Hz AC
Standard Fuels	Natural gas, LPG, heavy oil, light oil, coal, wood, coke, Biomass and BAGASSE
Display	Blue back lit graphic LCD
Menu	Intuitive structure, tab selection on screen
Dimensions	75 x 168 x 65 mm
Function buttons/key pad	5 button keypad
Weight	440 g (0.97lbs)
Pump	Flow fail indication, SmartPurge
Enclosure	Integrated robust protective case
Standards	BS7927, EN50379, BS7967
Data Logging Reports	Up to 200 reports, depending on type

### Probes

#### Standard Efficiency Flue Probe

Insertion length	250 mm (9.9") with adjustable depth gauge
Maximum temperature	800°C (1472°F)
Construction	Ergonomic pistol grip with stainless steel shaft, in-built with thermocouple, in-line water trap/filter
K-type thermocouple	Accuracy $\pm 1^{\circ}\text{C}$ or $\pm 0.3\%$ of reading, whichever is best Protective shaft for thermocouple
Hose length	2500 mm (8.2')

#### Gas Leak Sensor Probe

Gas Leak Sensor:	0-10,000ppm natural gas
------------------	-------------------------

## Gases

	Range	Display Resolution	Accuracy	Detection limit	Response time (t90)	Recovery time	Diagnostics
Oxygen	0-25%	0.1%	± 0.2%	0.3% v/v	50 sec	30 sec	✓
Carbon monoxide	0-10,000ppm (H <sub>2</sub> compensated, optional)	1ppm	<20ppm; ±3ppm >20ppm; ±3%	1ppm	90 sec	60 sec	✓
Carbon dioxide (Calculated)	0-25%	0.1%	±0.2% v/v	0.2% v/v	50 sec	30 sec	
CO/CO <sub>2</sub> ratio	0 to 0.9999	0.0001					

## Other Measurements

Measurement	Range
Temperature (selectable °C or °F)	-50° to 1100°C (-58° to 2012°F)
Efficiency	0-100% (net or gross selectable)
XSAir	0-100%

## Draught/Pressure Measurement

Let-by/Tightness Test	Dedicated test and report/print structure for combined test to IGE/11/UP/1B
-----------------------	---

## Pressure Scale

Range	-150 mbar to +150 mbar
Resolution	0.1 mbar
Accuracy	±0.5% of reading calibration at +50 mbar (equivalent to ±0.5 mbar)
Equivalent scales	Pa, hPa, kPa, PSI, inWG, mmWG, inHG, mmHG

## Communications

IR Port  
USB

## X. Accessories and spare parts

### Accessory list

Telegan part number	Description
------------------------	-------------



#### General Spares

CAS29002	SPRINT V CARRY CASE
SFW29001	SPRINT V CD ROM
PRB29002	SPRINT V LEAK PROBE
PRB29000	SPRINT V MAIN PROBE INC WATER TRAP WITH FILTER
TUB29000	SPRINT V Neoprene Tube - 1/4"ID x 3/8" OD (6.35 mm x 9.53 mm)
ENC29001	SPRINT V PROTECTIVE BOOT WITH MAGNETS
CHG29001	SPRINT V UK CHARGER
FIL29001	SPRINT V WATER TRAP INC. FILTER
INS29602	SPRINT V2 INSTRUCTION CARD A5
FIL99008	FILTER ELEMENT
C01296	CHARGING LEAD FOR VEHICLE LIGHTER SOCKET

---

## VI. Logging

---

Sprint provides the option to log the results of tests. When a test is complete, use the soft key  to log the results. The display will show the *Create log* screen detailing the log number, log title, date and time. Press the accept key  to 'Store log?'. The log details recorded are then displayed on the screen. Press the  key to continue or the soft keys to print or delete the log.

### Recalling logs

To recall a log, use the ESC key to display the *Main* menu. Logs can be recalled either by viewing and selecting from the log list or by entering the log number. The log list displays the log number, test title and date. Use the soft keys to choose *Select a log* or *Find a log by number*.



When the log has been selected, Sprint will display the log on the screen. Use the soft key options to *Print* or *delete* the log. Use the ESC key to exit the log list and Stored logs menu.

### Printing logs

Logs can be printed instantly from the test screen or from Stored logs or directly after a log has been recorded and the log is displayed on the screen. Press the *Print* soft key  to send the log file to the printer.

### Deleting logs

**Single logs** can be deleted either from the Stored logs menu or directly after a log has been recorded and the log is displayed on the screen. From the *Stored logs* menu choose *Select a log* or *Find a log by number* to find the log you wish to delete. Delete the log using the  soft icon.

**All logs** can be deleted from the *Stored logs* menu. Scroll and select *Delete all logs* and press the  soft key. Press the yes  key 'Are you sure?' to delete all logs or press ESC to cancel. Deleting all logs resets next log number to one.

---

## VII. Printing

---

Ensure your selected printer is switched on with paper roll installed and ready for use.

Ensure that the IR window on Sprint is aligned with the IR window on the printer. The printer may be up to 1 m away from the Sprint unit. If a report can be printed, a printer icon will appear on the screen. Press the soft key under the icon for an instant print. Ensure printer is set to PC (or suitable) mode.

## VIII. Troubleshooting guide

Sprint will provide on-screen messages which advise clear actions. Contact Anton if unsure on how to proceed.

Symptom	Cause	Recommended User Action:
Instrument will not turn on when on/off button is pressed and held for 2 seconds.	Battery flat	Connect charger and retry. Battery may be flat. The instrument is designed to prevent deep discharge occurring and will turn it self off when battery level gets too low.
Instrument will not turn on and charger symbol is not displayed when charger is connected.	Battery flattened beyond standard charging point.	Ensure charger is correct type. If so, plug-in and leave connected. Check to see if charging symbol appears every 4-6 hours. If it does not and unit does not switch on, return both unit and charger for service.
Pump sometimes stays on at a faster rate, particularly when exiting the Flue Gas Analysis or CO Room Test.	Smart purge is operating. CO sensor is recovering from exposure to gas.	Remove probe from flue. Continue to use the instrument as normal.
Pump flow fail alert	Filter/water trap or sample line blocked.	Empty and clean filter/water trap. Ensure sample line is free from blockage.
Printer does not respond or report contains odd characters.	Printer may be off, faulty, out of range, incorrectly set-up, have a low battery or not facing Sprint.	Ensure printer is charged up and turned on, working, set-up correctly with 'PC' protocol, within physical range (usually 1m) and with the IR window facing the IR window on Sprint. (Other IR sources such as a PC or sunlight may give odd character print-out)

<b>Symptom</b>	<b>Cause</b>	<b>Recommended User Action:</b>
Auto-zero failed	Sensors exposed to gas or faulty.	Switch off and on, ensuring you zero in clean air and sensors are purged. If unit continues to fail auto-zero, return for service.
Alarm activates in CO Room safety test	CO is reading greater than 30ppm.	Dependant on safety procedures.
Cannot remember the supervisor password.	Forgotten	Supervisor password prevents alteration of report header which identifies owner of the instrument. This provides security against theft. So there is no method to remotely unlock the instrument. Return for reset
During auto zero the CO reading does not stabilise.	CO sensor faulty or recovering from high CO exposure	Return for service ASAP or ensure unit is purged and allow sensor to recover.
Sometimes negative CO readings are displayed.	High CO exposure zeroed in auto zero sequence	Turn off and on and repeat auto zero in clean outside air, allowing time for the CO sensor to recover and stabilise.
Sometimes “!>” or “!<” is displayed in place of a number.	Sensor is out of range.	Contact support for advice. Return for service if problem persists or other failures are observed.
Cal due date has changed.	Time/date has been amended.	Check current date and time is correct. If the cal due date is set to more than a year's time then return for service ASAP.

# Appendix I: Carbon Monoxide Room Safety Tests

Sprint V instruments are designed to assist heating engineers to work to the BS 7967:2005 specification for carbon monoxide room safety testing. You should refer to BS7967, which defines the requirements, details the methods as well as the pass and fail criteria for various types of appliances.

CO Room Safety Test in the Sprint V instruments is designed to measure the build up of carbon monoxide levels in a room where a gas appliance is in use and record those values each minute for the duration of the test. In addition at the end of the test it assists the engineer (in an advisory capacity only) to determine whether the test has passed or failed or if the results are invalid. In certain circumstances, where the results are borderline or open to interpretation, the instrument will ask the operator to decide if the test has passed or failed, and will record the operators decision.

**Please note:** ultimately it is the responsibility of the operator to ensure that the test is correctly performed to the BS 7967:2005 specification. If the data does not support the result or the operator suspects it is not reliable due to local conditions (such as carbon monoxide level changes due to cigarette smoke or vehicle traffic) or incorrect, then either the test should be repeated or the operator should seek expert advice.

## CO Room Test Pass and Fail Test Specifications

	Type C: Room sealed appliance	Type B: Boiler (open flue)	Type A: Cooker (flueless)	Type A: Water heater (flueless)	Type A: Space heater (flueless)
Max Allowed CO:	10 ppm	10 ppm	30 ppm	10 ppm	10 ppm
Max Peak Duration exceeding Max Allowed CO:	60 secs	60 secs	20 mins	30 secs	60 secs
CO Alarm Level:	30 ppm	30 ppm	90 ppm	30 ppm	30 ppm
Min Test Duration:	15 mins	15 mins	20 mins	5 mins	30 mins
Max Test Duration:	30 mins	30 mins	30 mins	10 mins	30 mins

## Result Codes

The pass or fail result is displayed when the test completes and is printed on the report as well as recorded in the log. If the test fails a code number is also displayed, printed on the report and recorded in the log. This fail code identifies the way in which the test failed and can help identify the cause. Also when

the test completes a short text message associated to this code is displayed in a pop-up prompt dialog screen, to explain the reason for failure.

The result codes and associated prompt dialogue messages are as follows:

<b>RESULT &amp; CODE</b>	<b>POP-UP PROMPT ON-SCREEN</b>
"PASSED"	None
ANY "FAILED"	"Warning - CO Room Safety test failed."
"FAILED (1)"	CO levels did not fall or unstable.
"FAILED (2)"	CO unacceptably high (for too long).
"FAILED (3)"	CO dangerously high.
"FAILED (4)"	Unacceptable or incomplete.
	<b>"Press ESC key to continue."</b>

## Pass Cases

### Normal Acceptable Peak of CO

Normally for a test to pass, the CO levels must peak without exceeding the maximum allowed CO level and then fall (by at least 0.5 ppm) below the peak value before the end of the test. Note that it is not necessary for the CO level to reach or be close to zero at the end of the test, so long as it remains below the maximum allowed CO level.

The result code is: **PASSED**

### Very Low Levels of CO

If the CO levels remain below 2.5 ppm (ie: close to clean air or background noise levels) for the duration of the test, then the test is considered to have passed.

The result code is: **PASSED**

## Failure Cases

### Excessive Levels of CO

If the CO level exceeds the CO alarm level then the test is considered to have failed and should be immediately aborted. The CO alarm may be triggered at any stage (before, during and after completion of the test) and continues to announce until the CO level returns to a safe level.

The result code is: **FAILED (3)**

**NB:** The alarm should prompt the operator to take appropriate action according to BS7967 and safety procedures. The sensors in the instrument should be purged with clean air and allowed to recover.

### **Unacceptable Levels of CO**

A peak duration timer records whenever the CO level exceeds the maximum allowed CO level during the test. If the total peak duration time exceeds the max peak duration allowed then the test failed due to unacceptable levels of CO.

The result code is: **FAILED (2)**

### **Acceptable Levels of CO with no Peak**

If there is no peak in CO level even though it remains below the maximum allowed CO level, then the test is failed.

The result code is: **FAILED (1)**

### **Operator Pass/Fail Cases**

The following results are considered to be operator determined whether the test passes or fails:

#### **CO Level Exceeds Max Allowable Level for a Short Duration**

For some appliances (eg: cooker) a peak exceeding the maximum allowed CO level may be acceptable, provided the CO level falls back below this level within the max peak duration time. It is up to the operator to determine if the result is acceptable or not.

If the operator chooses to fail the test, the result code is: **FAILED (4)**

Otherwise the result code is: **PASSED**

### **Other Cases**

When a test is not performed correctly, the results are inconclusive or there is insufficient or unreliable data Sprint V attempts to interpret the readings detected and fail the test. It is possible for the results of a test to appear to be valid when it was performed incorrectly or the data collected was unreliable in some way. Please refer to BS7967:2005 and ensure tests are carried out correctly. Sprint V tries to reject incorrectly taken test readings but should not be relied on to instruct engineers on correct working practice.

### **Multiple Peaks of CO**

The overall peak CO reading recorded will be the latest peak CO reading that was higher than any previous. The peak duration recorded will be the total time the CO readings exceeded the maximum allowed CO level. The pass / fail criteria are applied as before based on this information. Sprint V does not expect to record multiple peaks of CO where the reading goes up and down more than once.

### **Unstable or Rising Levels of CO**

If the CO level in the last minute of the test is not lower than the overall peak CO reading then Sprint V assumes that the CO level has not fallen so the test will fail. The test will also fail if there is a significant build up of CO levels at the end of the test and levels are still rising or the CO level in the last minute of the test is not lower than the overall peak CO reading.

The result code is: **FAILED (1)**

### **CO Level Exceeds Max Allowable Level and Peaks for Unknown Duration**

If the CO level exceeds the maximum allowed too close to the end of the test then the test is failed. This can occur if there is a build up of CO levels towards the end of the test or the appliance fires up late on in the test or the test is stopped too early. The test should be repeated if this occurs.

The result code is: **FAILED (2)**

### **CO Level Does Not Start Close to Zero**

It is important that the instrument is zeroed in clean air at switch-on. Failure to do so will invalidate the test result. BS 7967-2:2005 also requires that the room is well ventilated prior to starting the test. However it is possible that there may be a residual background CO level (eg: due to traffic fumes). The instrument will display a pop-up box prior to starting the test if the CO level is more than 2.5 ppm.

# ANTON

*Technical helpline: Tel: +44 (0)870 428 0075*

**Manufactured by:**

Telegas Gas Monitoring  
A division of Crowcon Detection  
Instruments Ltd  
2 Blacklands Way,  
Abingdon Business Park  
Abingdon  
Oxfordshire OX14 1DY  
United Kingdom  
Tel: +44 (0)1235 557700  
Fax: +44 (0)1235 557749  
Email: [sales@telegangas.co.uk](mailto:sales@telegangas.co.uk)  
Web site: [www.telegangas.co.uk](http://www.telegangas.co.uk)

**Exclusive UK Distributor:**

Anton Industrial Services Ltd  
Unit 6 Park House  
15/23 Greenhill Crescent  
Watford Business Park  
Watford.  
Hertfordshire WD18 8PH  
United Kingdom  
Tel: +44 (0)870 428 0075  
Fax: +44 (0)870 428 0076  
E-mail: [sales@anton-group.com](mailto:sales@anton-group.com)  
web: [www.anton-group.com](http://www.anton-group.com)

