

HILTI

PS 38



Bedienungsanleitung	de
Operating instructions	en
Mode d'emploi	fr
Istruzioni d'uso	it
Manual de instrucciones	es
Manual de instruções	pt
Gebruiksaanwijzing	nl
Brugsanvisning	da
Bruksanvisning	sv
Bruksanvisning	no
Käyttöohje	fi
Οδηγίες χρήσεως	el
Használati utasítás	hu
Instrukcja obsługi	pl
Инструкция по эксплуатации	ru
Návod k obsluze	cs
Návod na obsluhu	sk
Upute za uporabu	hr
Navodila za uporabo	sl
Ръководство за обслужване	bg
Kullanma Talimatı	tr
Lietošanas pamācība	lv
Instrukcija	lt
Kasutusjuhend	et
ІНСТРУКЦІЯ З ЕКСПЛУАТАЦІЇ	uk

CE

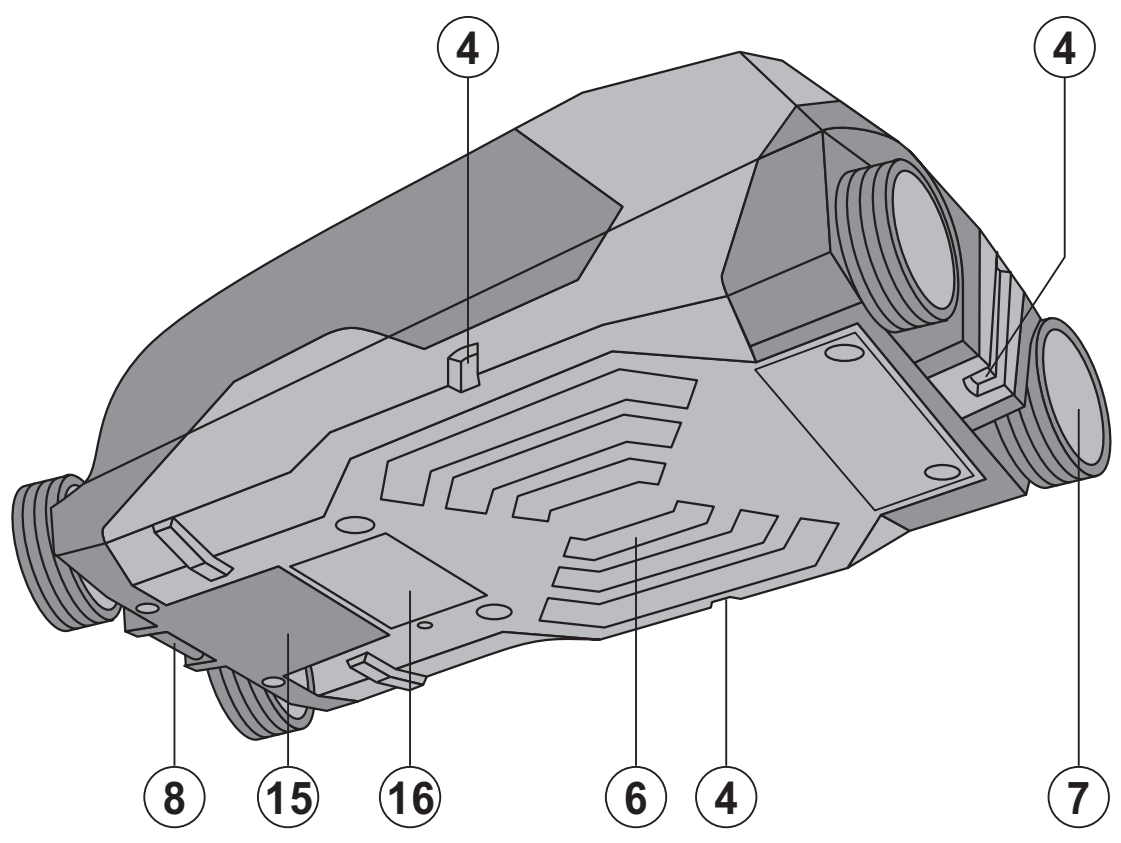
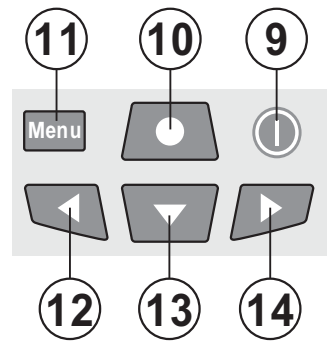
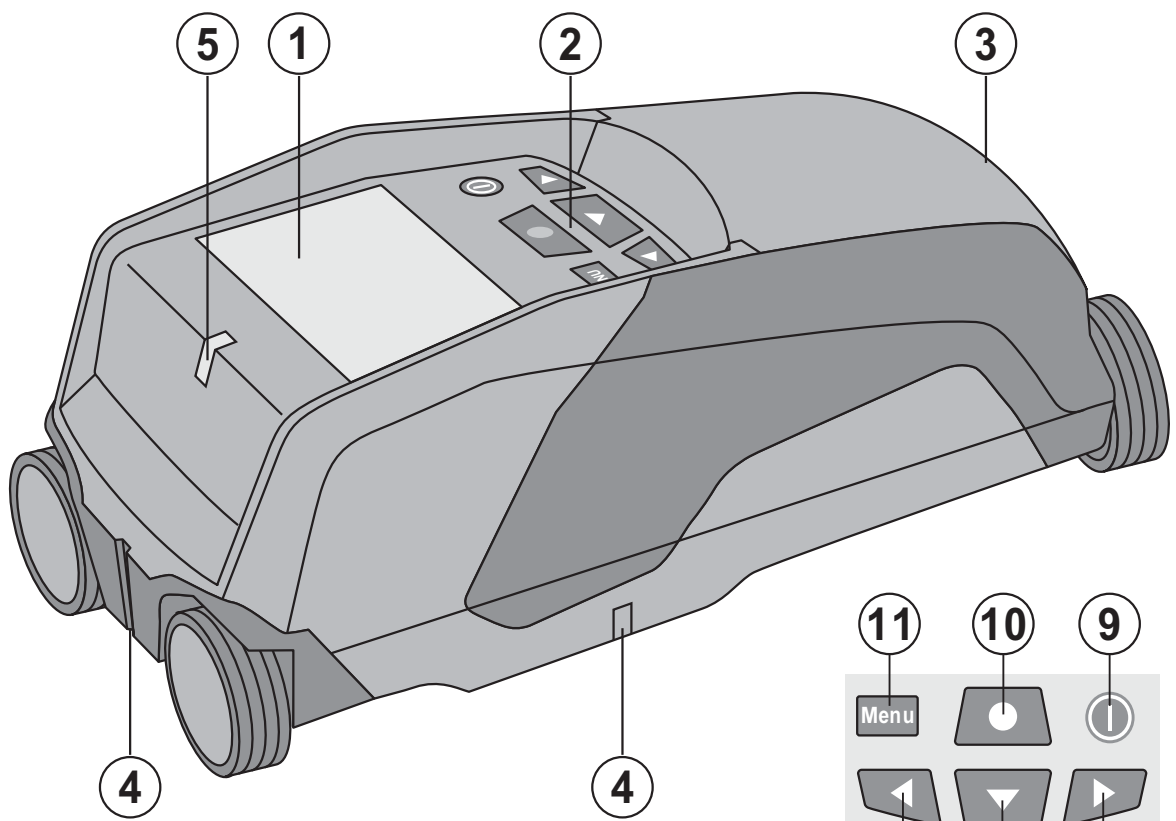

2

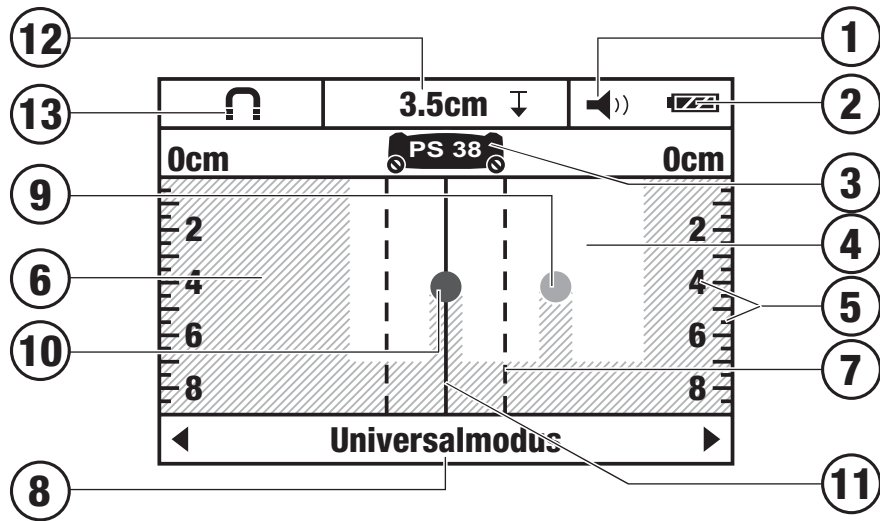

3

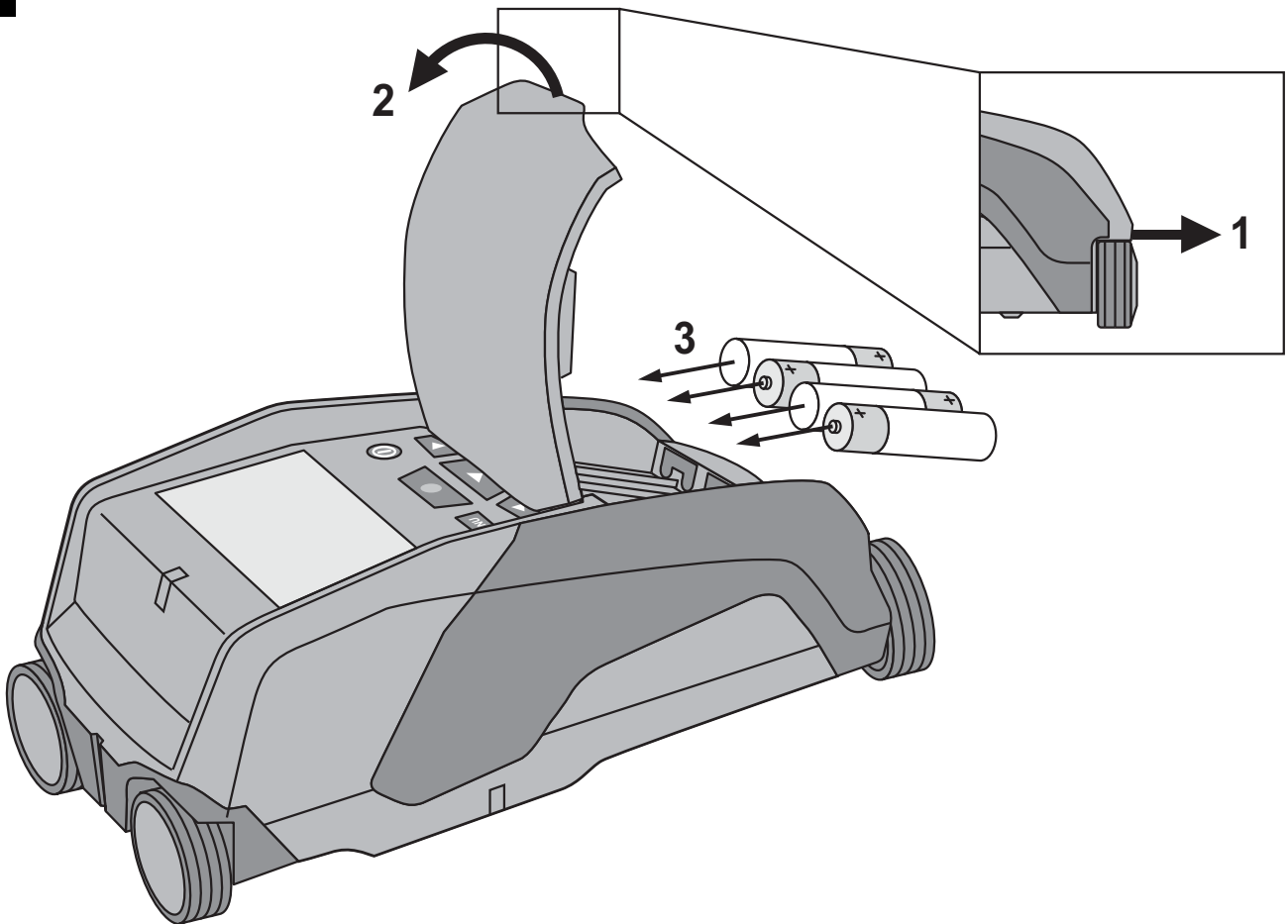

4

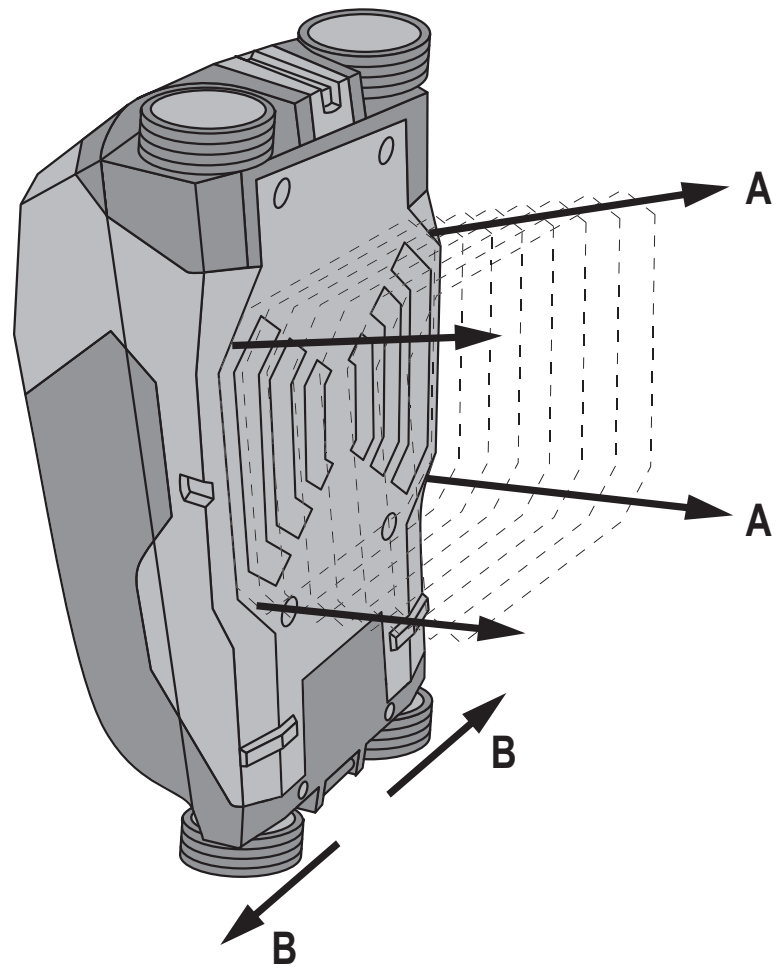

5

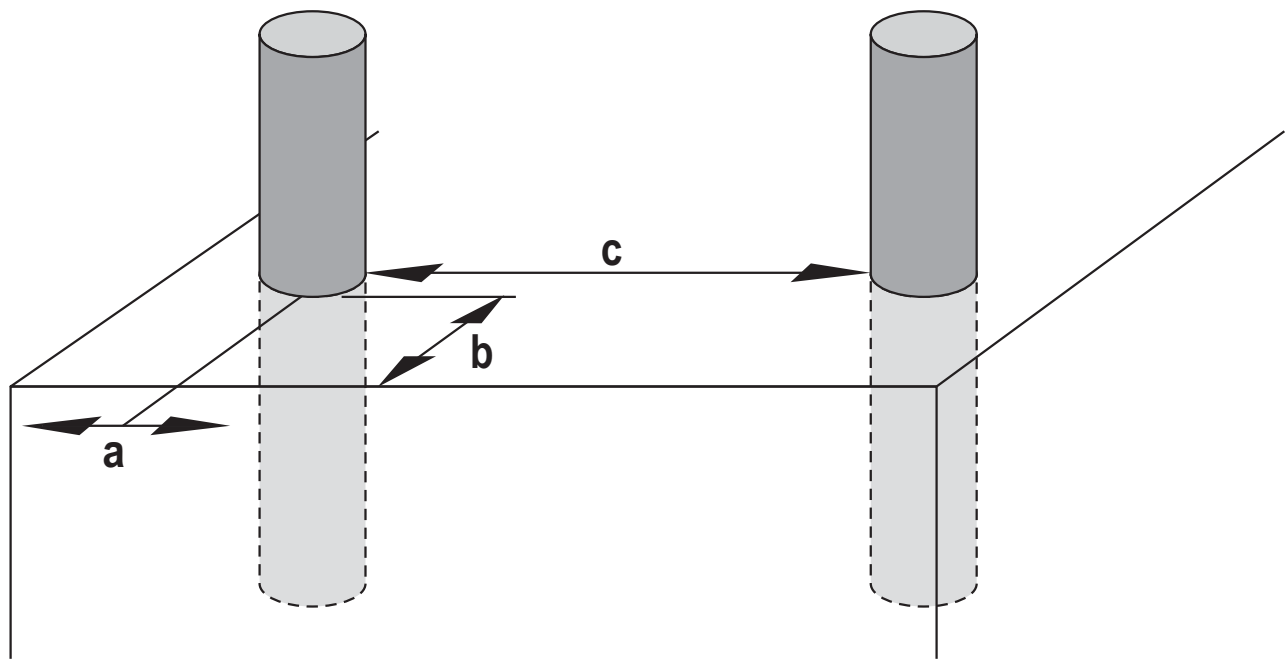

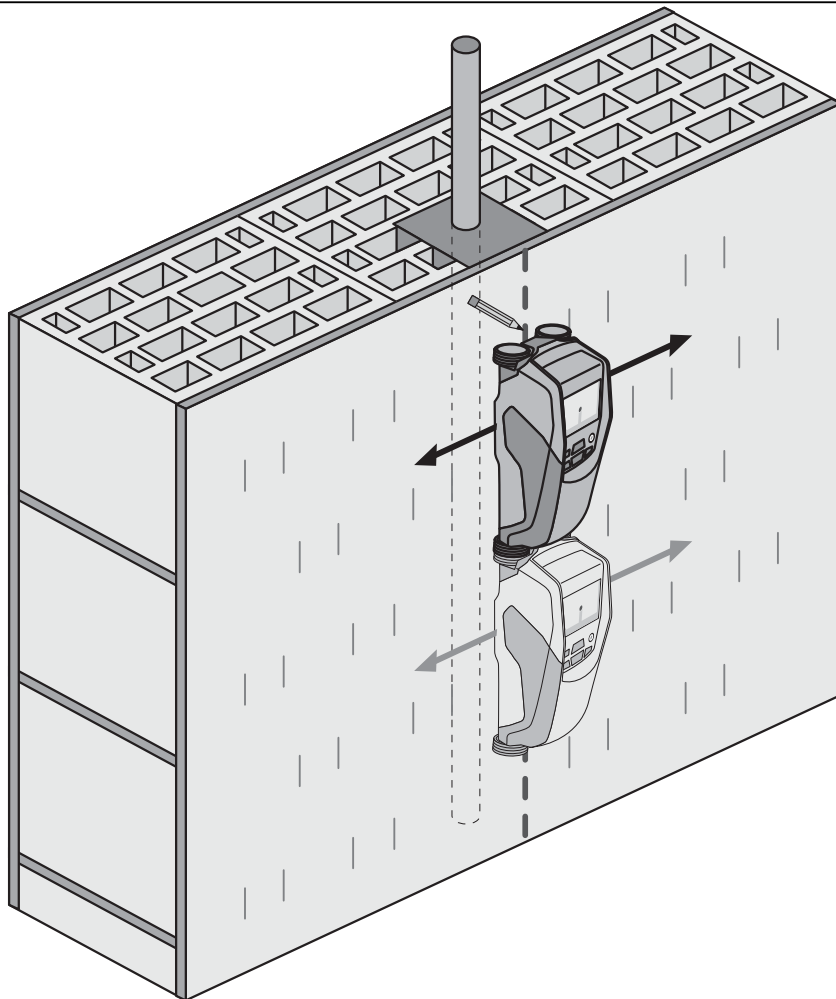

ORIGINAL OPERATING INSTRUCTIONS

PS 38 multidetector

It is essential that the operating instructions are read before the tool is operated for the first time.

Always keep these operating instructions together with the tool.

Ensure that the operating instructions are with the tool when it is given to other persons.

Contents	Page
1. General information	16
2. Description	16
3. Technical data	18
4. Safety instructions	18
5. Before use	20
6. Operation	22
7. Care and maintenance	25
8. Troubleshooting	25
9. Disposal	26
10. Manufacturer's warranty	27
11. EC declaration of conformity	27

1 These numbers refer to the corresponding illustrations. The illustrations can be found on the fold-out cover pages. Keep these pages open while studying the operating instructions.

In these operating instructions, the designation "the tool" always refers to the PS 38 Multidetector.

Parts and operating controls **1**

- 1 Display
- 2 Control panel
- 3 Battery compartment
- 4 Marking notches
- 5 Status LED (red / green)
- 6 Sensor area
- 7 Wheel
- 8 Wrist strap attachment point
- 9 On/off button
- 10 Measure button
- 11 Menu button
- 12 "Left" button
- 13 "Down" button
- 14 "Right" button
- 15 Service cover
- 16 Type identification plate

Display **2**

- 1 Signal tone indicator
- 2 Battery status indicator
- 3 Sensor area indicator
- 4 Already scanned area
- 5 Scale showing approximate depth of the object
- 6 Unscanned area
- 7 Position of outside edge (for marking a detected object at one of the lateral marking notches)
- 8 Scanning mode indicator
- 9 Gray: detected object is outside the sensor area
- 10 Black: detected object is inside the sensor area
- 11 The middle line corresponds with the upper marking notch
- 12 Approximate depth of the object
- 13 Object category or live cable indicator

en

1. General information

1.1 Safety notices and their meaning

DANGER

Draws attention to imminent danger that could lead to serious bodily injury or fatality.

en

WARNING

Draws attention to a potentially dangerous situation that could lead to serious personal injury or fatality.

CAUTION

Draws attention to a potentially dangerous situation that could lead to slight personal injury or damage to the equipment or other property.

NOTE

Draws attention to an instruction or other useful information.

1.2 Explanation of the pictograms and other information

Warning signs



General warning

Symbols



Read the operating instructions before use.



Return waste material for recycling.

Location of identification data on the tool

The type designation and serial number can be found on the type identification plate on the tool. Make a note of this data in your operating instructions and always refer to it when making an enquiry to your Hilti representative or service department.

Type: _____

Generation: 01 _____

Serial no.: _____

2. Description

2.1 Use of the product as directed

The PS 38 Multidetector is designed to detect objects such as ferrous metals (rebars), non-ferrous metals (copper and aluminium), wood beams, plastic pipes, electric cables in dry materials.

Further information and examples of applications can be found at www.hilti.com/detection





The tool and its ancillary equipment may present hazards when used incorrectly by untrained personnel or when used not as directed.

Observe the information printed in the operating instructions concerning operation, care and maintenance.

Take the influences of the surrounding area into account. Do not use the appliance where there is a risk of fire or explosion.

Modification of the tool is not permissible.

2.2 Displaying object categories

Symbol	Ferrous metal
	
Symbol	Non-ferrous metal
	
Symbol	Plastic / wood
	
Symbol	Live electric cable
	
Symbol	Unknown object
	

en

2.3 Detectable objects

- Steel reinforcing bars
- Metal pipes (e.g. steel, copper, aluminium)
- Plastic pipes (e.g. plastic pipes containing water, e.g. floor or wall heating, etc.)
- Cavities
- Wood beams
- Electric cables (irrespective of whether the cables are live or not)
- Three-phase electric cables (e.g. for electric cookers)
- Low-voltage cables (e.g. for doorbells or telephones)

2.4 Materials suitable for scanning

- Concrete / steel reinforced concrete
- Masonry (brick, cellular concrete, expanded concrete, pumice concrete, sand-lime block)
- Materials beneath surfaces such as plaster, tiles, wallpaper, parquet, carpet
- Wood, plasterboard / gypsum board

2.5 Scanning limitations

- Due to the scanning principle employed, certain unfavorable circumstances may negatively affect the result:
- Multiple layers on walls or floors
 - Empty plastic pipes in hollow brick, wood beams in cavities and in drywall partitions
 - Objects that run through the wall at an angle
 - Metal surfaces and damp areas; under certain circumstances, these may be detected as objects in the material being scanned
 - Cavities in the material being scanned; these may be detected as objects
 - Proximity to appliances that emit powerful magnetic or electromagnetic fields, e.g. mobile or cordless phone base stations and generators

2.6 Items supplied

- 1 The tool
- 1 Hand strap
- 4 Batteries
- 1 Operating instructions
- 1 Manufacturer's certificate
- 1 Soft pouch
- 1 Set of marking pens
- 1 Hilti toolbox

3. Technical data

Right of technical changes reserved.

NOTE

¹⁾ Depends on scanning mode, the size and type of the object and on the condition and type of material to be scanned (see fig. 5 on the cover pages).

PS 38

Maximum detection range for locating objects ¹⁾	12 cm (4.7 in)
Location accuracy (to the middle of the object) a ¹⁾	± 5 mm (± 0.2 in)
Depth measurement accuracy b ¹⁾	± 10 mm (± 0.4 in)
Minimum distance between two objects c ¹⁾	4 cm (1.57 in)
Operating temperature range	-10...+50°C (14 °F ... 122 °F)
Storage temperature range	-20...+70°C (-4 °F ... 158 °F)
Batteries	4 x 1.5 V LR06 (AA)
Batteries	4 x 1.2 V HR06, KR06 (AA)
Battery life (alkaline batteries)	5 h
Battery life (with 2500 mAh batteries)	7 h
Protection class	IP 54 (protection against dust and water spray)
Weight in accordance with EPTA procedure 01/2003	0.7 kg (1.5 lb)
Dimensions (L x W x H)	195 mm x 90 mm x 75 mm (7.7 in x 3.5 in x 3.0 in)

4. Safety instructions

In addition to the information relevant to safety given in each of the sections of these operating instructions, the following points must be strictly observed at all times.

4.1 Basic information concerning safety

- a) **Keep children away from the tool.**
- b) **Check the display after switching the tool on.** The display should show the Hilti logo and the name of the tool. The display then shows the current settings or the settings previously saved.

- c) **Operation of the tool in the proximity of persons with a cardiac pacemaker is not permissible.**
- d) **Operation of the tool in the proximity of pregnant women is not permissible.**
- e) Rapidly changing detection conditions may lead to inaccurate readings.
- f) **Do not use the tool in the proximity of medical instruments and appliances.**
- g) **Do not drill at positions where the tool has located an object.**

- h) The warnings shown in the display must always be observed.
- i) Due to the scanning principle employed, the results of the scan may be negatively affected by certain ambient conditions. These include, e.g. proximity to appliances that generate powerful magnetic or electromagnetic fields, dampness, construction materials containing metal, aluminium foil-backed insulation, multiple layers, materials with cavities or electrically conductive wall coverings or tiles. Accordingly, other sources of information (e.g. plans of the building) should also be consulted before beginning drilling, sawing or grinding in the area scanned.
- j) Take the influences of the surrounding area into account. Do not use the tool where there is a risk of fire or explosion.
- k) Make sure that the display area can be easily read (e.g. do not touch the display area with the fingers, keep the display area clean).
- l) Do not use the tool if it is defective.
- m) Always keep the detection area clean.
- n) Always check how the tool is set before using it.
- o) Operation of the tool in the proximity of military installations, airports or astronomical facilities is not permissible unless prior permission has been obtained.

4.2 Proper organization of the workplace

- a) Avoid unfavorable body positions when working from ladders. Make sure you work from a safe stance and stay in balance at all times.
- b) When the tool is brought into a warm environment from very cold conditions, or vice-versa, allow it to become acclimatized before use.
- c) Use the tool only within its specified limits.
- d) Observe the accident prevention regulations applicable in your country.

4.3 Electromagnetic compatibility

The tool complies with the requirements of EN 302435. Accordingly, permission must be obtained prior to operating this tool, for example, in hospitals, atomic power stations or in the proximity of airports or mobile phone relay stations.

4.4 General safety instructions

- a) Check the condition of the tool before use. If the tool is found to be damaged, have it repaired at a Hilti service center.
- b) Keep the tool clean and dry at all times.
- c) Do not apply stickers or adhesive plates at the sensor area on the underside of the tool. Metal plates, in particular, will affect scanning results.
- d) Take care to ensure that the service cover on the tool is always securely closed. The service cover may be opened only at a Hilti Service Center.
- e) The user must check the accuracy of the tool after it has been dropped or subjected to other mechanical stresses.
- f) Although the tool is designed for the tough conditions of jobsite use, as with other measuring instruments it should be treated with care.
- g) Although the tool is protected to prevent entry of dampness, it should be wiped dry each time before being put away in its transport container.
- h) Check the accuracy of the tool before using it for detection or measurement.

en

4.5 Electrical safety

- a) Keep the batteries out of reach of children.
- b) Remove the batteries from the tool if it is to remain unused for some time. The batteries will self-discharge and may begin to corrode if stored for a long period.
- c) Always replace all batteries at the same time. Use only batteries of the same capacity and from the same manufacturer.
- d) Do not allow the batteries to overheat and do not expose them to fire. The batteries may explode or release toxic substances.
- e) Do not charge the batteries.
- f) Do not solder the batteries into the tool.
- g) Do not discharge the batteries by short-circuiting. This may cause them to overheat and present a risk of personal injury (burns).
- h) Do not attempt to open the batteries and do not subject them to excessive mechanical stress.

4.6 Transport

Always remove the batteries before shipping the tool.

5. Before use



en

5.1 Inserting the batteries 3

CAUTION

Do not use damaged batteries.

CAUTION

Always replace the complete set of batteries.

CAUTION

Do not mix old and new batteries. Do not mix batteries of different makes or types.

1. Release the catch on the underside of the tool and open the battery compartment cover.
2. Insert the batteries in the tool. Close the cover and check that it engages in the closed position.

NOTE Take care to observe correct polarity (see symbols in battery compartment).

The battery status indicator in the display on the tool shows the charge status of the batteries.

3. Check to ensure that the battery compartment cover is closed correctly.

5.2 Switching the tool on / off

1. Switch the tool on by pressing the on/off button. The status LED lights green and the display shows the start-up screen.

2. When the tool is already switched on, press the on/off button: The tool switches off.

NOTE When the warning "Please change the batteries" appears in the display, the settings will be saved and the tool will switch itself off.

NOTE If no scan is made or no button is pressed, the tool will switch itself off automatically after 5 minutes. The cut-off time can be set in menu mode (see section 5.5.4 "Cut-off time")

5.3 Changing the scanning mode

The "Left" and "Right" buttons can be used to scroll through the various scanning modes. By changing the scanning mode the tool can be adjusted to achieve optimum results on various materials and, where necessary, detection of undesired objects can be

suppressed (e.g. cavities in bricks). The currently active setting is shown in the lower area of the display.

5.3.1 Universal mode (default setting)

The scanning mode for most applications in solid masonry or concrete is "Universal mode". In this mode, metal or plastic objects and electric cables are detected. Cavities in brick or empty plastic pipes with a diameter of less than 2 cm (0.8 in) will probably not be detected. The maximum detection depth is 8 cm (3.2 in).

5.3.2 Concrete

The "Concrete" scanning mode is particularly suitable for use on concrete. In this mode, steel reinforcing bars, plastic or metal pipes and electric cables are detected. The maximum detection depth is 12 cm (4.7 in).

"Universal mode" should be selected in order to avoid scanning errors when the tool is used on thin concrete walls.

5.3.3 Floor heating

The "Floor heating" scanning mode is particularly suitable for detecting metal, metal composite and water-filled plastic pipes or electric cables under a layer of screed. The maximum detection depth is 8 cm (3.2 in).

NOTE

Empty plastic pipes will not be found.

5.3.4 Drywall

The "Drywall" scanning mode can be used to find wood beams, metal framing parts, pipes containing water and electric cables in drywall partitions. The maximum detection depth is 8 cm (3.2 in).

NOTE

Empty plastic pipes will not be found.

5.3.5 Hollow brick

"Hollow brick" mode is suitable for use on masonry containing a large number of cavities. In this mode, metal objects, water-filled plastic pipes and live electric cables will be detected. The maximum detection depth is 8 cm (3.2 in).

NOTE

Empty plastic pipes and electric cables carrying no electric power will not be detected.

5.4 Changing the display mode

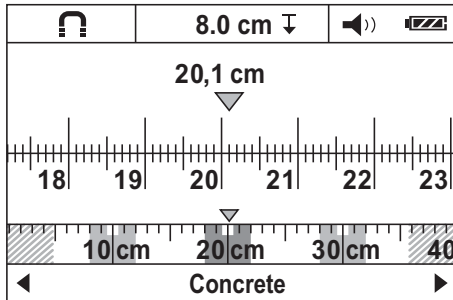

The display mode can be changed in all scanning modes. This function changes only the display mode, not the scanning mode.

To change from the standard display to distance measurement mode, press the “Left” or “Right” button for more than 2 seconds. The display mode can be changed again by pressing one of these buttons.

NOTE

Distance measurement mode can be used to measure the distance between objects. In the illustration shown, three equally spaced metal objects have been detected (see section 6.3.1 “Example showing re-bars”).

The distance scanned (from the starting point of the scan) is shown in the display below the approximate depth of the object, e.g. 20.1 cm (7.9 in), as shown in the example. The three objects detected, which are each a distance of 10 cm (3.9 in) apart, are shown as small rectangles above the scanning mode.

5.5 “Settings” menu

To enter the “Settings” menu, press the “Menu” button.

To leave the “Settings” menu, press the “Menu” button again.

The settings selected up to this point will be saved and the tool then returns to the standard display screen.

5.5.1 Navigating in the menu

1. To access the menu items, press the “Down” button.

The selected menu item is highlighted in gray.

2. Press the “Left” or “Right” button to change the selected menu item.

5.5.2 Brightness

The brightness of the display can be adjusted in the “Brightness” menu. The default setting is “Max” (maximum brightness).

5.5.3 Signal tones

In the “Signal tones” menu you can choose whether or not an audible signal is emitted when an object is detected. In the default setting, the signal tone is active.

5.5.4 Cut-off time

The time interval before the tool switches itself off automatically when no scan is made or when no button is pressed can be set in the “Cut-off time” menu. The default setting is “5 min.”.

5.5.5 Default mode

The mode to be used as standard after the tool is switched on can be set in the “Default mode” menu. “Universal mode” is the default setting.

5.5.6 Language

The language used in the display and in the menus can be changed in the “Language” menu. “English” is the default setting.

5.5.7 Units

Use this menu to select metric or imperial units of measure. The default setting is “metric”.

5.6 “Extended settings” menu

To access the “Extended settings” menu, press the “Menu” button and the “On/off” button simultaneously while the tool is switched off.

To leave the menu, press the “Measure” button.

NOTE

The submenus can be used to display information about the tool or to restore the default settings.

en

6. Operation



en

6.1 Using the tool 4

The tool scans in direction “A” to the depth indicated in the display. Scanning takes place only while the tool is being moved in direction “B” and so long as the tool is moved a distance of at least 10 cm (3.9 in). Always move the tool in a straight line over the area to be scanned, applying light and even pressure so that the wheels remain securely in contact with the surface. Objects that differ from the material being scanned will be detected. The display shows the position of the object, its approximate depth and, when possible, the object category. Optimum results will be achieved when the scan has a length of at least 40 cm (15.7 in) and the tool is moved slowly over the surface to be scanned. Due to the operating principle employed, the upper edges of objects that lie transversely to the scanning direction will be reliably detected.

Accordingly, always scan the area crosswise (i.e. in two scans perpendicular to each other) in order to avoid errors due to scanning along the length of an object.

NOTE

When several objects are positioned one above the other in the material being scanned, the object closest to the surface will be shown in the display. The image of the object shown in the display may differ from the actual characteristics of the object concerned. In particular, very thin objects will be shown thicker than they actually are. Large, cylindrical objects (e.g. plastic objects or water pipes) shown in the display may appear narrower than they actually are.

6.2 Scanning

1. Switch the tool on.
The display shows the standard screen.
Select the scanning mode that suits the material to be scanned.

2. Place the tool on the surface to be scanned and move it in the required direction (see section 6.1 “Using the tool”).

The result of the scan will be shown in the display after the tool has been moved a distance of at least 10 cm (3.9 in).

3. In order to obtain correct results, move the tool slowly over the area to be scanned.

NOTE If the tool is lifted away from the surface while making the scan, the most recent reading is shown in the display. The word “Hold” appears in the sensor area of the display. The scan restarts when the tool is brought back into contact with surface and moved again or the “Measure” button is pressed.

NOTE The approximate depth and the object material category shown in the display refer to the object shown in black in the sensor area of the screen.

The status LED lights red when an object is within the sensor area and lights green when no object is detected. When the status LED blinks red, a live cable is very probably within the sensor area.

If an object is present below the sensor it is shown in the sensor area of the display. Depending on the size and depth of the object detected, the object category may also be shown. The approximate depth to the upper edge of the object detected is shown in the status line or can be read from the scale at the side of the display.

6.2.1 Locating objects

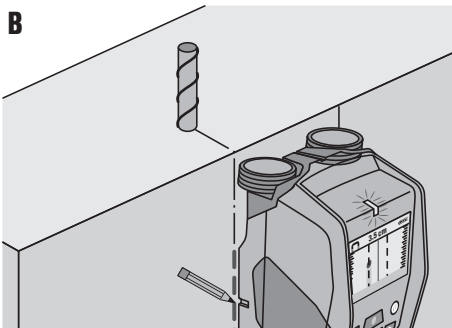
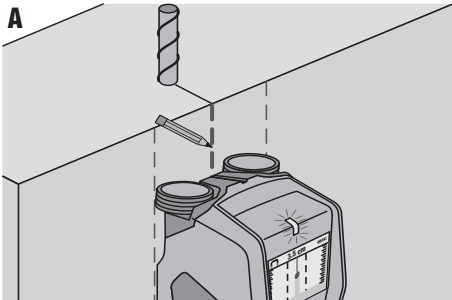

1. A single scan of the area is sufficient for initial location of an object.
2. If no object is found, repeat the scan at right angles to the direction of the original scan (see section 6.1 "Using the tool").
3. If you wish to locate an object exactly and mark its position, simply move the tool in the reverse direction back across the area already scanned.
4. If an object appears in the display immediately below the center line, as shown in illustration A, the position of the object can be marked on the surface at the upper marking notch.
NOTE However, this mark will be accurate only when the object runs exactly perpendicular to the direction of scan as the sensor area lies slightly below the marking notch.
5. To mark the position more exactly, move the tool to the left or right until the object detected is shown at the edge of the display.
6. Mark the position of the detected object by making a mark beside the right or left marking notch (see illustration B).

NOTE The object detected lies at the point of intersection of the upper and side marking notches.

6.3 Examples of scan results

NOTE

In the following examples, the signal tone is switched on.

6.3.1 Steel reinforcing bars

A steel object, e.g. a steel rebar, is present in the sensor area. To the left and right of this are other objects which are outside the sensor area. The depth of the object is approx. 8 cm (3.1 in). The tool emits a signal tone.

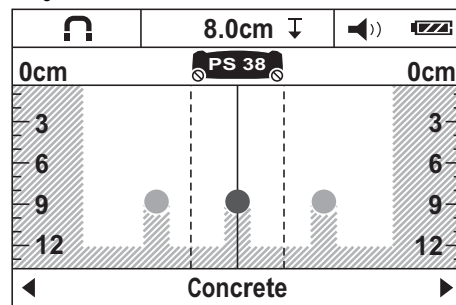

NOTE

Best scanning results will be obtained when the tool is moved at right angles to the longitudinal rebars, as described above. Mark the positions of the rebars found and then shift the tool to the adjoining area above or below and repeat the scan in order to verify the position of the rebars and the direction in which they run. To locate the transverse rebars, pivot the tool through 90° and scan between the already detected longitudinal rebars in order to avoid scanning along a longitudinal rebar.

6.3.2 Copper pipes

A non-ferrous metal object, e.g. a copper pipe, is within the sensor area. It lies at a depth of approx. 4 cm (1.6 in). The tool emits a signal tone.

en

en

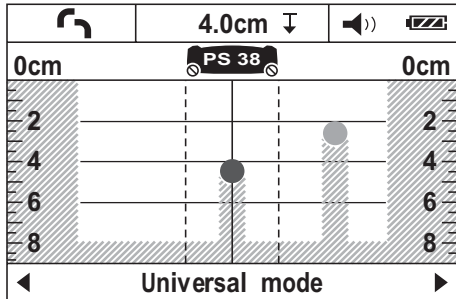

6.3.3 Plastic or wooden objects

A non-metallic object is within the sensor area. The object is made of plastic or wood (or is a cavity) and lies close to the surface. The tool emits a signal tone.

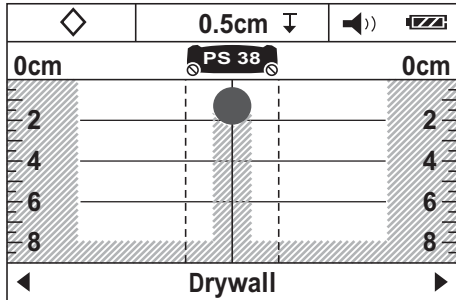

6.3.4 Live electric cables

NOTE

Depending on the size and depth of the object, it is not always possible to determine without doubt whether it is live (i.e. carrying electricity).

NOTE

When scanning, do not lay your hands on the surface of the material.

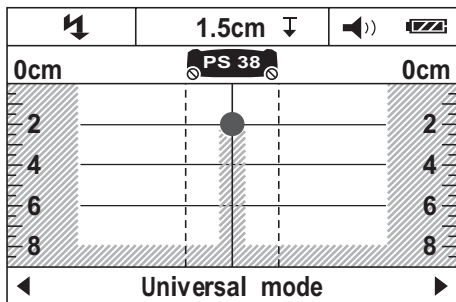

A live metallic object, e.g. an electric cable, is within the sensor area. It lies at a depth of approx. 1.5 cm (0.6 in). The tool emits a warning signal tone for “live cables” as soon as the electric cable is detected by the sensor.

6.3.5 Objects with a large surface area

A metal object with a large surface area, e.g. a metal plate, is within the sensor area. It lies at a depth of approx. 2 cm (0.8 in). The tool emits a signal tone.

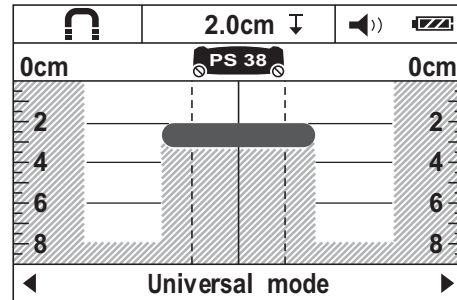

6.3.6 Unclear signals

If a large number of objects are indicated in the standard display area, there can be two reasons for this.

1. The wall probably contains a large number of cavities (hollow brick).

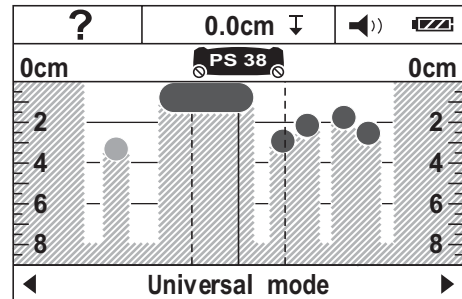

Switch to “Hollow brick” mode. Most of the cavities will then no longer be shown in the display.

If too many objects are still shown, several scans must be made at different heights and the position of the objects detected marked on the wall.

Offset marks tend to indicate cavities while marks in a line tend to indicate an object.

2. The scan has been made longitudinally, i.e. along the length of an object. In this case, move the tool up or down and repeat the scan (see fig. 6 on the cover pages).

7. Care and maintenance

7.1 Cleaning and drying

1. Use only a clean, soft cloth for cleaning. If necessary, moisten the cloth slightly with pure alcohol or a little water.

NOTE Do not use any other liquids as these may damage the plastic components.

2. The temperature limits for storage of your equipment must be observed, especially in winter / summer.

7.2 Storage

Put the tool into storage only when dry. Please observe the applicable temperature limits when storing the tool.

Check the accuracy of the equipment before it is used after a long period of storage.

Remove the batteries from the tool before storing it for a long period. Leaking batteries may damage the tool.

7.3 Transport

Use the Hilti toolbox or equivalent packaging when transporting the tool.

CAUTION

Always remove the batteries before shipping the tool.

7.4 Hilti Calibration Service

We recommend that the tool is checked by the Hilti Calibration Service at regular intervals in order to verify its reliability in accordance with standards and legal requirements.

Use can be made of the Hilti Calibration Service at any time, but checking at least once a year is recommended.

The Calibration Service provides confirmation that the tool is in conformance, on the day it is tested, with the specifications given in the operating instructions. After checking, a calibration sticker applied to the tool and a calibration certificate provide written verification that the tool is operating in accordance with the manufacturer's specification.

Calibration certificates are always required by companies certified according to ISO 900x.





Your local Hilti Center or representative will be pleased to provide further information.

en

8. Troubleshooting

Fault	Possible cause	Remedy
The tool can't be switched on.	The batteries are exhausted.	Replace the batteries.
	Incorrect battery polarity.	Insert the batteries correctly and close the battery compartment cover.
The tool is switched on but doesn't react.	System error.	Remove and reinsert the batteries.
The tool is too cold or too hot.	The tool is too cold or too hot.	Wait until it is within the permissible temperature range.
"Slipping wheel" is shown in the display.	A wheel lost contact with the wall.	Press the "Measure" button. Take care to ensure that the wheels remain in contact with the surface when moving the tool. On uneven surfaces, place a sheet of thin cardboard between the wheels and the wall.
"Too fast" is shown in the display.	The tool was moved too quickly.	Press the "Measure" button. Move the tool slowly over the wall.

en

Fault	Possible cause	Remedy
<p>"Out of temperature range" is shown in the display.</p> 	Temperature above permissible range.	Wait until within the permissible temperature range.
<p>"Out of temperature range" is shown in the display.</p> 	Temperature below permissible range.	Wait until within the permissible temperature range.
<p>The display shows "Tool temperature"</p> 	The temperature inside the tool has changed too quickly.	Switch the tool on again.
<p>"Strong radio signal detected" is shown in the display.</p> 	Interference caused by radio signal. The tool switches itself off automatically.	If possible, eliminate the radio signal (e.g. WLAN, UMTS, aircraft radar, transmitter mast or microwave device) and switch the tool back on.

9. Disposal



Most of the materials from which Hilti tools or appliances are manufactured can be recycled. The materials must be correctly separated before they can be recycled. In many countries, Hilti has already made arrangements for taking back old tools or appliances for recycling. Ask Hilti Customer Service or your Hilti representative for further information.



For EC countries only

Disposal of electrical appliances together with household waste is not permissible.

In observance of European Directive 2002/96/EC on waste electrical and electronic equipment and its implementation in accordance with national law, electrical appliances that have reached the end of their life must be collected separately and returned to an environmentally compatible recycling facility.

10. Manufacturer's warranty

Hilti warrants that the tool supplied is free of defects in material and workmanship. This warranty is valid so long as the tool is operated and handled correctly, cleaned and serviced properly and in accordance with the Hilti Operating Instructions, and the technical system is maintained. This means that only original Hilti consumables, components and spare parts may be used in the tool.

This warranty provides the free-of-charge repair or replacement of defective parts only over the entire lifespan of the tool. Parts requiring repair or replacement as a result of normal wear and tear are not covered by this warranty.

Additional claims are excluded, unless stringent national rules prohibit such exclusion. In particular, Hilti is not obligated for direct, indirect, incidental or consequential damages, losses or expenses in connection with, or by reason of, the use of, or inability to use the tool for any purpose. Implied warranties of merchantability or fitness for a particular purpose are specifically excluded.

en

For repair or replacement, send the tool or related parts immediately upon discovery of the defect to the address of the local Hilti marketing organization provided.

This constitutes Hilti's entire obligation with regard to warranty and supersedes all prior or contemporaneous comments and oral or written agreements concerning warranties.

11. EC declaration of conformity

Designation:	Multidetector
Type:	PS 38
Year of design:	2009

We declare, on our sole responsibility, that this product complies with the following directives and standards: 1999/5/EC, 2004/108/EC, EN 55022, EN 55024, EN 61010-1, EN 302435-1, EN 302435-2.

Hilti Corporation



Dietmar Sartor
Head of BA Quality and Process
Management
Business Area Electric Tools & Accessories
02 2010



Tassilo Deinzer
Head BU Measuring Systems

BU Measuring Systems

02 2010



en



HILTI

Hilti Corporation

LI-9494 Schaan

Tel.: +423/234 21 11

Fax: +423/234 29 65

www.hilti.com



419205