

EUROPE'S LARGEST SELECTION OF TEST & MEASUREMENT EQUIPMENT FOR HIRE

INLEC.COM

DATA-SHEET



Nationwide Low Call
0333 6000 600

WHY BUY
WHEN YOU CAN HIRE

Getting Started Guide

The DSX CableAnalyzer modules attach to Versiv™ main and remote units to make rugged, hand-held testers that let you certify, troubleshoot, and document twisted pair network cabling.

DSX-5000 modules certify twisted pair cabling to Cat 7_A/Class F_A limits (1000 MHz) in 15 seconds.





DSX-8000 modules certify twisted pair cabling to Cat 8/Class I/II limits (2000 MHz) in less than 16 seconds.

Accessing the Product Manuals

This guide provides basic information to help you get started using the tester. For more detailed information, see the latest versions of the *Versiv Users Manual* and the *Versiv Technical Reference Handbook* provided on the Fluke Networks website.

To download manuals, go to www.flukenetworks.com/support.

Symbols

| | |
|------------------------------------------------------------------------------------|--------------------------------------------------------------------------------------------------------------|
|  | Warning or Caution: Risk of damage or destruction to equipment or software. See explanations in the manuals. |
|  | Warning: Risk of fire, electric shock, or personal injury. |
|  | Consult the user documentation. |
|  | Do not connect this equipment to public communications networks, such as telephone systems. |



| | |
|------------------------------------------------------------------------------------|-------------------------------------------------------------------------------------------------------------------------------------------------------------------------------------------------------------------------------------------------------------------------------------------------------------------------------------------------------------------------------------------------------------------------------------------------------------------------------------------------------------------------------------------------------------------------------------|
|  | <p>This product complies with the WEEE Directive marking requirements. The affixed label indicates that you must not discard this electrical/electronic product in domestic household waste. Product Category: With reference to the equipment types in the WEEE Directive Annex I, this product is classed as category 9 "Monitoring and Control Instrumentation" product. Do not dispose of this product as unsorted municipal waste.</p> <p>To return unwanted products, contact the manufacturer's web site shown on the product or your local sales office or distributor.</p> |
|  | Conformite Europeene. Conforms to the requirements of the European Union and the European Free Trade Association (EFTA). |
|  | Certified by CSA Group to North American safety standards. |
|  | Conforms to relevant Australian standards. |
|  | 40 year Environment Friendly Use Period (EFUP) under China Regulation - Administrative Measure on the Control of Pollution Caused by Electronic Information Products. This is the period of time before any of the identified hazardous substances are likely to leak out, causing possible harm to health and the environment. |
|  | Conforms to relevant Russian standards. |
|  | <p>KCC-REM-FKN-012001001: EMC approval for Korea Class A Equipment (Industrial Broadcasting & Communication Equipment)</p> <p>This product meets requirements for industrial (Class A) electromagnetic wave equipment and the seller or user should take notice of it. This equipment is intended for use in business environments and is not to be used in homes.</p> |
|  | This key turns the Product on and off. |

Safety Information

Warning

To prevent possible fire, electric shock, or personal injury:

- Read all safety information before you use the Product.
- Carefully read all instructions.
- Do not connect the tester to telephony inputs, systems, or equipment, including ISDN inputs. Doing so is a misapplication of this product, which could result in damage to the tester and create a potential shock hazard to the user.
- Do not open the case. You cannot repair or replace parts in the case.

- **Do not modify the Product.**
- **Use only replacement parts that are approved by Fluke Networks.**
- **Do not touch voltages > 30 V AC rms, 42 V AC peak, or 60 V DC.**
- **Do not use the Product around explosive gas, vapor, or in damp or wet environments.**
- **Use this Product indoors only.**
- **Do not connect the Product to voltages that are higher than the maximum voltage rating for the Product.**
- **For Products that have multiple connectors for different types of tests on copper cabling, disconnect unused test leads from the connectors before you do a test.**
- **Use the Product only as specified, or the protection supplied by the Product can be compromised.**
- **Do not use and disable the Product if it is damaged.**
- **Do not use the Product if it operates incorrectly.**
- **Batteries contain hazardous chemicals that can cause burns or explode. If exposure to chemicals occurs, clean with water and get medical aid.**
- **Remove the batteries if the Product is not used for an extended period of time, or if stored in temperatures above 50 °C. If the batteries are not removed, battery leakage can damage the Product.**
- **Replace the rechargeable battery after 5 years of moderate use or 2 years of heavy use. Moderate use is defined as recharged twice a week. Heavy use is defined as discharged to cutoff and recharged daily.**
- **Disconnect the battery charger and move the Product or battery to a cool, non-flammable location if the rechargeable battery becomes hot (>50 °C, >122 °F) during the charge period. The battery door must be closed and locked before you operate the Product.**
- **Repair the Product before use if the battery leaks.**
- **Recharge the batteries when the low battery indicator shows to prevent incorrect measurements.**
- **Turn off the Product and disconnect all test leads, patch cords, and cables before you replace the battery.**

- Do not disassemble or crush battery cells and battery packs.
- Do not put battery cells and battery packs near heat or fire. Do not put in sunlight.
- Do not operate the Product with covers removed or the case open. Hazardous voltage exposure is possible.
- Remove the input signals before you clean the Product.
- Have an approved technician repair the Product.
- Do not put metal objects into connectors.
- For Products with rechargeable batteries, use only AC adapters approved by Fluke Networks for use with the Product to supply power to the Product and charge the battery.

Caution

To prevent damage to the Product or cables under test and to prevent data loss, read all safety information given in all documentation supplied with the Product.

Connectors, Keys, and LEDs

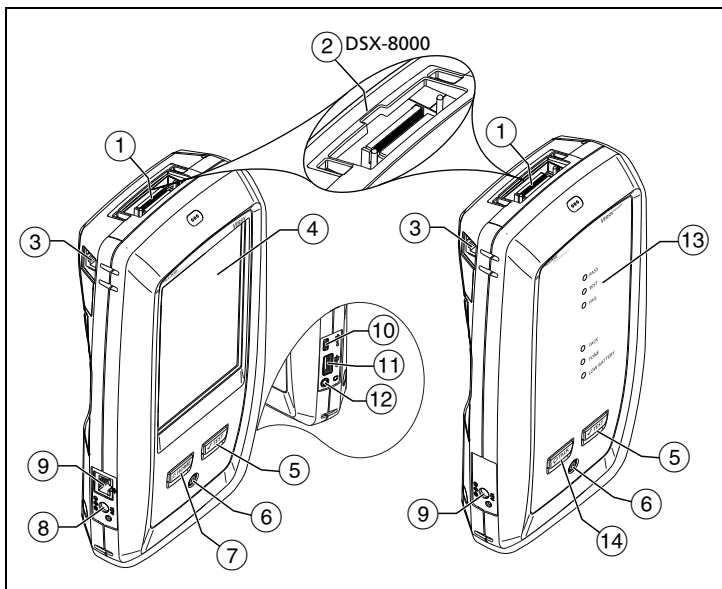





Figure 1. Connectors, Keys, and LEDs

HFO00EPS

- ① Connector for a link interface adapter.

- ② DSX-8000 modules have a recess for the tabs on Cat 8/Class I/II adapters. You cannot attach Cat 8/Class I/II adapters to DSX-5000 modules.
- ③ RJ45 jack for communications between the main and remote testers when you do alien crosstalk measurements.
- ④ LCD display with touchscreen.
- ⑤ : Starts a test. To start a test, you can also tap **TEST** on the display.
- ⑥ Power key.
- ⑦ : Press  to go to the home screen.
- ⑧ Connector for the ac adapter. The LED is red when the battery charges, and green when the battery is fully charged. The LED is yellow if the battery will not charge.
- ⑨ RJ45 connector: Lets you connect to a network for access to Fluke Networks cloud services.
- ⑩ Micro-AB USB port: This USB port lets you connect the tester to a PC so you can upload test results to the PC and install software updates in the tester.
- ⑪ Type A USB port: This USB host port lets you save test results on a USB flash drive, connect the FI-1000 video probe to the tester, or connect a Wi-Fi adapter for access to Fluke Networks cloud services.

⑫ Headset jack.

⑬ **PASS** LED comes on when a test passes.

TEST LED comes on during a test.

FAIL LED comes on when a test fails.



TALK LED comes on when the talk function is on (see ⑬). To adjust the volume, press  or the button on the headset's microphone.

TONE LED flashes and the toner comes on when you press  and a main tester is not connected to the remote.

LOW BATTERY LED comes on when the battery is low.

Note

The LEDs also operate as a battery gauge when you turn on the remote. See the Users Manual.

⑭ : Press  to use the headset to speak to the person at the other end of the link. Press again to adjust the volume. To turn off the talk function, hold down .

How to Certify Twisted Pair Cabling

1. Power the Tester

Charge the battery if necessary. Connect the ac adapter to ac power and to the adapter connector (7) shown in Figure 1. You can use the tester while the battery charges.

2. Select Settings

2-1 On the home screen, tap the test setup panel (see Figure 2).

2-2 On the **CHANGE TEST** screen, tap a twisted pair test, then tap **EDIT**.

2-3 On the **TEST SETUP** screen, tap the panels to change settings.

2-4 To save the settings, tap **SAVE** on the **TEST SETUP** screen.

-continued-

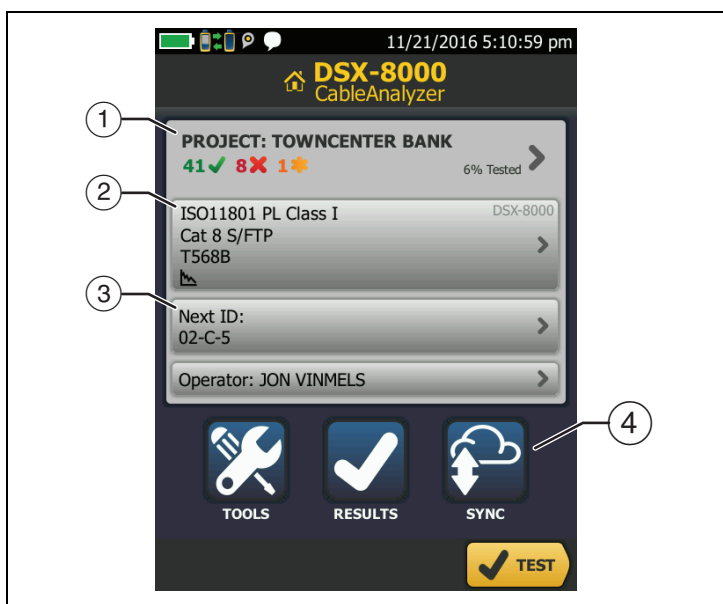

HFO01.EPS

Figure 2. Panels on the Home Screen

- 1 To set up a project, tap the **PROJECT** panel.
- 2 To change settings for the test or select a different test, tap the test setup panel.
- 3 To set up cable IDs and turn on **Auto Save**, tap the **Next ID** panel.
- 4 To upload test results to LinkWare Live, tap **SYNC**.

3. Make Connections and Do a Test

3-1 Connect the testers to the link as shown in Figure 3 or 4.

3-2 Tap **TEST** on the main tester or press  on the main or remote tester.

Note

Cat 8/Class III permanent links can have two connectors and a maximum length of 24 m. See the Users Manual for connection diagrams.

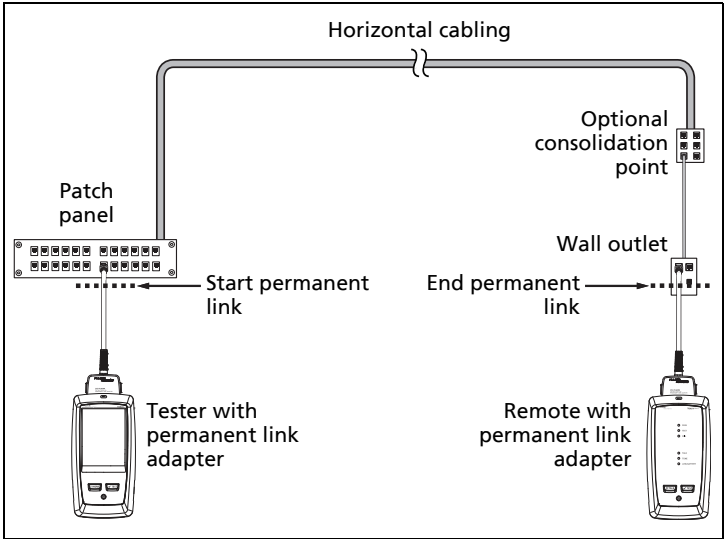

Figure 3. Permanent Link Connections for Links Up to Cat 7_A

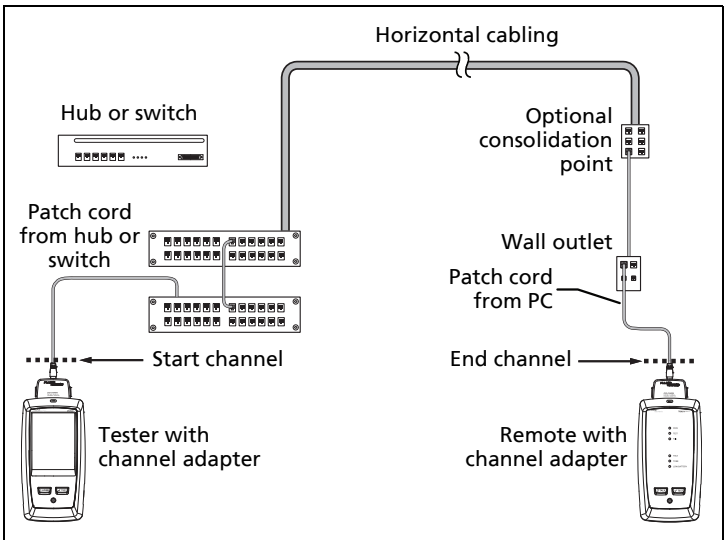
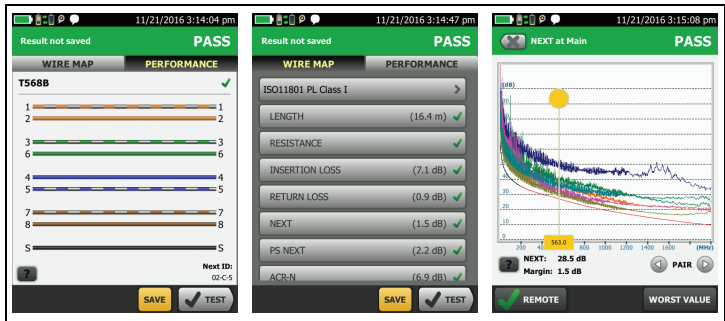

Figure 4. Channel Connections for Links Up to Cat 7_A

4. Examine the Results

The tester shows multiple views of the test results (Figure 5):

- **WIRE MAP:** Shows the connections between the ends of the cable under test. The tester compares the connections to the selected **Outlet Configuration** to get a **PASS** or **FAIL** result.
- **PERFORMANCE:** Shows the overall result for each test that is required by the selected test limit. To see detailed results for a test, tap the panel.
-



HFO02.EPS

Figure 5. Examples of Twisted Pair Results Screens

5. Save the Results

5-1 Tap **SAVE** if the test passed or **FIX LATER** if the test failed.

5-2 If the **Cable ID** box shows the correct ID, tap **SAVE**.

To enter a cable ID, tap the **Cable ID** box on the **SAVE RESULT** screen, use the keyboard to enter a name for the results, tap **DONE**, then tap **SAVE**.

The tester saves the results in the **DEFAULT** project, unless you selected a different project.

About Projects

You can set up a project to specify the settings and tests necessary for a job, monitor the status of a job, and organize the test results.

To start a new project, tap **PROJECT** on the home screen, tap **CHANGE PROJECT**, then tap **NEW PROJECT**. See the Users Manual or Technical Reference Handbook for more information.

About Fluke Networks Cloud Services

With a Fluke Networks web account and a wired or wireless network connection, you can use the LinkWare™ Live web application to store and manage projects in the cloud.

Go to <https://www.linkwarelive.com/signin> or see the Users Manual or Technical Reference Handbook for more information.

About the AxTalk Analyzer Kit

The DSX CableAnalyzer kit includes the hardware and AxTalk Analyzer software you need to do tests for alien crosstalk on twisted pair cabling. Alien crosstalk is noise, or crosstalk, transmitted between adjacent cables in a bundle or patch panel. Alien crosstalk is a primary source of noise in cabling used for 10GBASE-T applications.

For instructions on how to do alien crosstalk tests, install the AxTalk Analyzer software, which is available on the Fluke Networks website, then see the online help in the software.

Registration

Registering your product with Fluke Networks gives you access to valuable information on product updates, troubleshooting tips, and other support services.

To register, use LinkWare PC software. Download LinkWare PC from the Fluke Networks website.

Contact Fluke Networks



www.flukenetworks.com/support



support@flukenetworks.com



1-800-283-5853, +1-425-446-5500



Fluke Networks
6920 Seaway Boulevard, MS 143F
Everett WA 98203 USA

Fluke Networks operates in more than 50 countries worldwide. For more contact information, go to our website.

General Specifications

| | |
|----------------------|-------------------------------------------------------------------------------------|
| Battery Type | Lithium-ion |
| Power Adapter | Input: 100 to 240 VAC \pm 10%, 50/60Hz Output: 15 VDC, 2 A maximum Class II |
| Temperature | Operating: 0 °C to +45 °C Storage: -30 °C to +60 °C |
| Altitude | Operating: 4,000 m (3,200 m with AC adapter) Storage: 12,000 m |

Warranty

Limited 1-year warranty. See the product manual for details.

INLEC, supporting you to deliver a world class service, every day, in every sector ...



OUR COMMITMENT TO YOU

A wealth of knowledge and experience.

You can take advantage of expert advice to ensure you get the best, most appropriate and cost effective equipment for the job. We supply a wide variety of industries, so if there is another way to do the job or save you time and money we'll pass on the benefit of our experience for free.

Honest advice, just a phone call away.

If we don't have a particular item, rather than hiring you something that won't do the job, we would rather direct you to an alternative supplier. You will always be provided with full instructions and if you still need help, call our technical team on Nationwide Low Call 0333 6000 600. Our aim is to save you time, frustration and money.

Top quality equipment from major manufacturers.

With Inlec you'll get the most accurate, reliable and well-maintained equipment available. Prices are regularly reviewed to ensure you always enjoy the best value for money. We have made a significant investment in test equipment so we ensure that it's well packed to minimise damage and delay.

We really do listen to you.

You won't waste your time contacting Inlec. Every request for equipment is logged and carefully considered. Listening to our customers helps keep our product range up to date and relevant. If you are unhappy about any aspect of our service please let us know so we can put it right.

YOUR 5 WAY GUARANTEE

1 GUARANTEE SAME DAY DESPATCH

We understand why prompt delivery is important to you. So, if we confirm your order before 3pm, you are guaranteed same day despatch.

2 OUR PRICE GUARANTEE

Inlec guarantee you real value for money. Our price match policy is simple - if you can hire the same product for less elsewhere, we guarantee to match that price and reduce it by a further 10% of the difference - and still deliver our industry leading technical and customer support.

For full details check our price-match guarantee online

3 TOP QUALITY GUARANTEED

All equipment is thoroughly checked prior to dispatch to ensure you receive it in full, safe working order. Your shipment will be securely packed and include manufacturer's instructions, accessories or consumables and a valid calibration certificate where appropriate. In addition, Inlec offer a 24 hour replacement service if you decide the equipment is not suitable for your application*.

4 FRIENDLY, KNOWLEDGEABLE ADVICE GUARANTEED

Inlec are happy to provide you with free advice, from an unbeatable team of experienced, knowledgeable and friendly engineers and hire experts.

5 YOUR GUARANTEE OF THE BEST CUSTOMER SERVICE

Throughout your hire we will work hard to ensure you enjoy the very best in support and service from Inlec. We guarantee you won't find better service anywhere in the industry.

*subject to availability and conditions

Europe's leading Test Equipment Hire Specialist



LAB NO. 0535



Nationwide Low Call 0333 6000 600

Online: www.inlec.com

Inlec UK Ellerbeck Way, Stokesley Business Park, Stokesley N Yorkshire TS9 5JZ United Kingdom



CERT. NO. GB93/1773



Accredited Contractor