



# Datasheet



0370 330 6021

[www.sunbeltrentals.co.uk](http://www.sunbeltrentals.co.uk)

# HYDRAJAWS HOLLOW RAM HYDRAULIC EQUIPMENT

## Operating Instructions



## KIT CONTENTS

1. Aluminium Hollow Ram Cylinder  
- Choice of capacity
2. Hand Pump
3. 3 metre Hose Assembly incl Couplers
4. Digital Gauge
5. Case



## CONTENTS

	Page
KIT CONTENTS	2
DESCRIPTION OF OPERATION	3
SAFETY NOTES	3
INSTALLATION AND OPERATION	3
SERVICING	3
DIAGRAMS	4

## USE OF THE TESTER AS DIRECTED

The tester is intended for use by skilled personnel with the appropriate training and knowledge of the applicable safety precautions.



**It is essential that the operating instructions are read before the tester is operated for the first time.**

**Always keep these operating instructions together with the tester.**

**Ensure that the operating instructions are with the tester when it is given to other persons.**

## SAFETY RULES

- Modification of the tester, or tampering with its parts is not permissible.
- Observe the information printed in the operating instructions applicable to operation care and maintenance.
- The tester and its accessories may present hazards when used incorrectly by untrained personnel or not as directed.
- Use only the genuine Hydrajaws accessories or ancillary equipment listed in the operating instructions.

## DESCRIPTION OF OPERATION

The HP212 Hand Pump is a two speed manually operated hand pump suitable for a wide range of applications. It is supplied complete with a pre-filled oil reservoir ready for immediate use. It features low handle effort characteristics for easy operation and lightweight design and are of strong durable construction. It has a max working pressure of 700 bar and is of Aluminium construction.

## SAFETY NOTES

All equipment used must be rated for the same operating pressure (ie 700bar / 10,000 psi). **DO NOT** mix high and low pressure components. If in doubt contact Hydrajaws.

Sufficient time should be allocated to planning your hydraulic system. Make sure that all system components are adequate for the intended operation.

Ensure that the pump has sufficient oil capacity to operate the cylinder being used.

**DO NOT** exceed the rated pressure of the pump or rated capacity of the cylinder. Never tamper with the internal safety relief valve of the pump.

Whenever possible use a pressure gauge in the system to prevent overloading.

**This pump must only be used on single acting cylinders.**

Do not handle pressurised hoses. Oil escaping under pressure from a ruptured hose can penetrate the skin. Avoid damaging the hose.

Always fully support the base of the cylinder. Do not use directly on soft ground, use suitable load spreading plates

Never pressurise a HVL cylinder without an external load, as this will damage the cylinder base and may cause injury.

## INSTALLATION AND OPERATION

### General

Always check that hoses, couplings, cylinders and tools etc., that are connected to the pump are designed for use at a working pressure that equals or exceeds the maximum working pressure of the pump and check for any defective or damaged parts which should be repaired or replaced immediately.

### Typical Setup and Connection

The pump may be used either horizontally or vertically with the hose end downwards. The pump is equipped with a pressure relief valve factory set at the maximum operating pressure. Before use unscrew transit plug and replace with breather on the top of the tank (**see fig 1**). This will maximise the oil volume available.

To advance the cylinder, turn the release knob clockwise. Operate pump handle. The pump will automatically switch from low pressure (high flow) operation to high pressure (low flow) as the pressure increases (**see fig 2**).

**Note: The cylinder will automatically be held in the advance position and will not retract of its own accord.**

To retract the cylinder turn release knob anti-clockwise slowly, **a maximum of 1 to 2 turns**, ensuring that the cylinder does not retract too fast as to make the operation unsafe (**see fig 3**).

If pump is to be transported after use, replace the transit plug in tank.

After use, always fully retract pistons. When hoses are disconnected always fit dust caps to couplers (**see fig 4**).

Protect cylinders from the elements when not in use. If storing for prolonged periods, grease exposed metal parts. NEVER store cylinders in an extended piston condition.

**WARNING: DO NOT RELY ON THE PUMP VALVE FOR POSITIVE LOAD HOLDING. IF IT IS REQUIRED TO LOCK THE LOAD IN POSITION USE A MANUAL SHUT OFF VALVE IN THE CIRCUIT. NEVER WORK UNDER A LOAD SUPPORTED ONLY BY HYDRAULIC MEANS.**

## SERVICING

### Filling with oil

Ensure cylinder is fully retracted.

Position pump horizontal on a flat surface, remove plug on the top of the tank and check oil level. Fill-up with the recommended grade of oil until the level is approx. 10mm from the top of the tank.

Use only hydraulic mineral oils 32 grade and 46 grade.

### Bleeding the hydraulic system

Connect the cylinder to the pump. Position the cylinder below the level of the pump with its pressure ports uppermost.

Ensure the bleed screw on the pump is open. Operate the cylinder 3-4 times over its full stroke and all air should be forced back to the pump reservoir (**see fig 5**).

**Warning: when using a small cylinder with long hoses it is possible that air can remain trapped in the hose if the volume of the hose is greater than the volume of the cylinder. In this case the bleeding must be carried out using a shorter hose before use.**

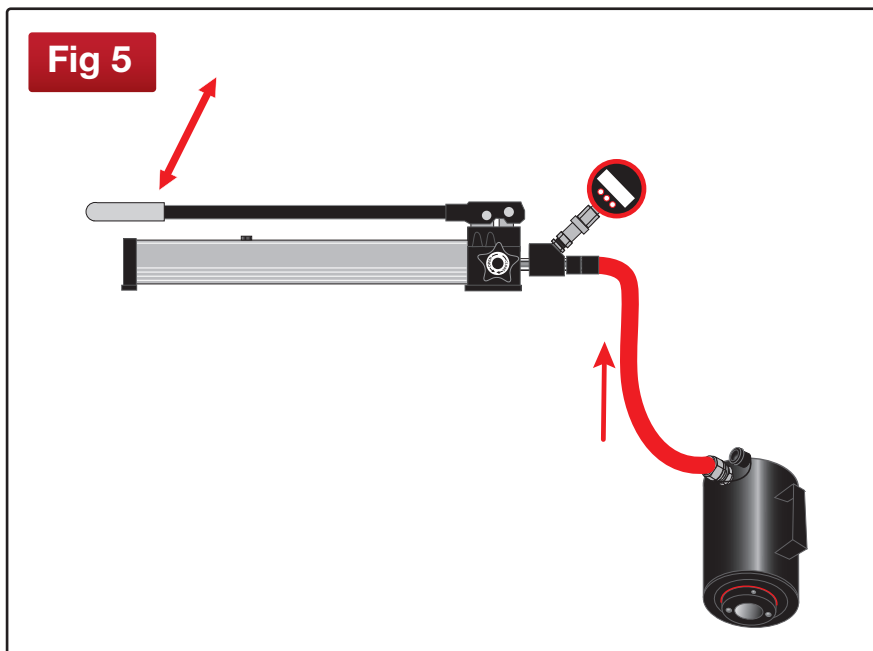
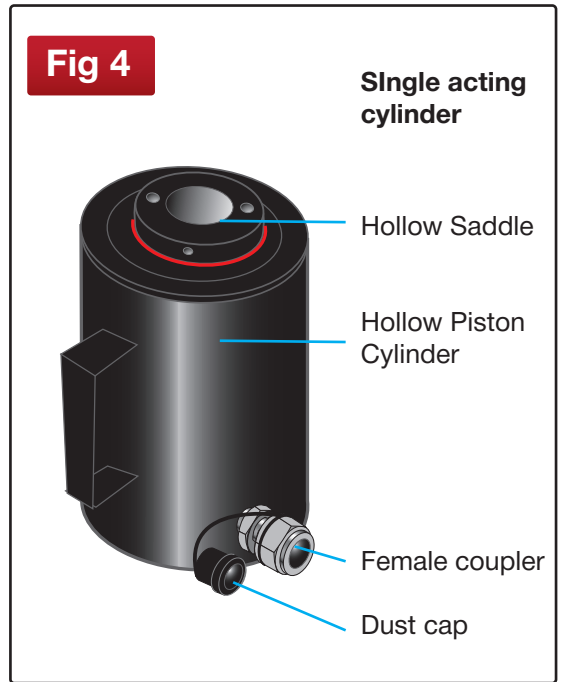
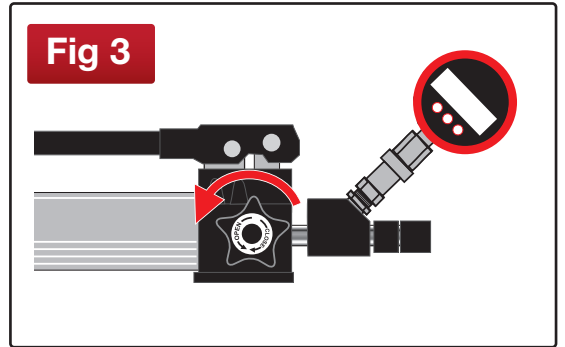
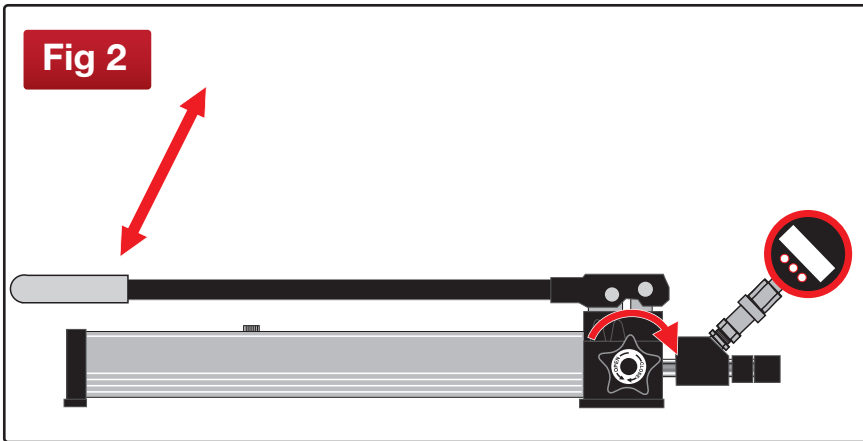
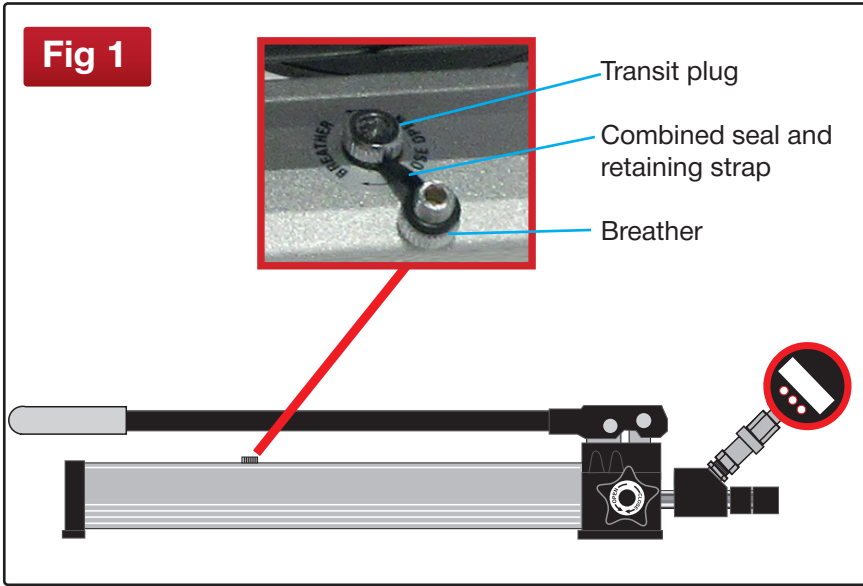

We are supporting you to deliver  
a world class service, every day,  
in every sector...

## LOCATIONS

### LONDON, HEATHROW

#### Sunbelt Rentals UK Test & Monitoring

242-252 London Road, Staines, London TW18 4JQ

0333 122 3126

[www.sunbeltrentals.co.uk/find-a-depot/london-heathrow](http://www.sunbeltrentals.co.uk/find-a-depot/london-heathrow)

### REDCAR

#### Sunbelt Rentals UK Test & Monitoring

Unit 5 Kirkleatham Business Park, Redcar TS10 5SQ

0370 330 6021

[www.sunbeltrentals.co.uk/find-a-depot/teesside](http://www.sunbeltrentals.co.uk/find-a-depot/teesside)

### STOKESLEY

#### Sunbelt Rentals UK Test & Monitoring

2 Ellerbeck Way, Stokesley Business Park, Stokesley, North Yorkshire TS9 5JZ

01642 718 900

[www.sunbeltrentals.co.uk/find-a-depot/stokesley](http://www.sunbeltrentals.co.uk/find-a-depot/stokesley)



[www.inlec.com](http://www.inlec.com)

Order Online with Next Day  
Delivery, Online Chat & Online  
Account Management



★ Trustpilot

View our trustpilot score



STOKESLEY  REDCAR

 HEATHROW

0370 330 6021

[instrumentation@sunbeltrentals.co.uk](mailto:instrumentation@sunbeltrentals.co.uk)

[testequipment@sunbeltrentals.co.uk](mailto:testequipment@sunbeltrentals.co.uk)

[www.sunbeltrentals.co.uk](http://www.sunbeltrentals.co.uk)

