

CPC 100

User Manual



Manual information

Article Number VESD0601 - Manual Version: ENU 1036 05 07

© OMICRON electronics 2019. All rights reserved.

This product includes software developed by Intrinsic Software.

This manual is a publication of OMICRON electronics GmbH.

All rights including translation reserved. Reproduction of any kind, for example, photocopying, microfilming, optical character recognition and/or storage in electronic data processing systems, requires the explicit consent of OMICRON. Reprinting, wholly or in part, is not permitted.

The product information, specifications, and technical data embodied in this manual represent the technical status at the time of writing and are subject to change without prior notice.

We have done our best to ensure that the information given in this manual is useful, accurate and entirely reliable. However, OMICRON does not assume responsibility for any inaccuracies which may be present.

The user is responsible for every application that makes use of an OMICRON product.

OMICRON translates this manual from the source language English into a number of other languages. Any translation of this manual is done for local requirements, and in the event of a dispute between the English and a non-English version, the English version of this manual shall govern.

Support

When you are working with our products we want to provide you with the greatest possible benefits. If you need any support, we are here to assist you!

 **24/7 Technical support – get support**
www.omicronenergy.com/support

At our technical support hotline, you can reach well-educated technicians for all of your questions. Around the clock – competent and free of charge.

Make use of our 24/7 technical support hotlines:

Americas: +1 713 830-4660 or +1 800-OMICRON

Asia-Pacific: +852 3767 5500

Europe / Middle East / Africa: +43 59495 4444

Additionally, you can find our Service Center or Sales Partner closest to you at www.omicronenergy.com.

 **Customer area – stay informed**
www.omicronenergy.com/customer

The customer area on our website is an international knowledge exchange platform. Download the latest software updates for all products and share your own experiences in our user forum.

Browse through the knowledge library and find application notes, conference papers, articles about daily working experiences, user manuals and much more.

 **OMICRON Academy – learn more**
www.omicronenergy.com/academy

Learn more about your product in one of the training courses offered by the OMICRON Academy.

OMICRON electronics GmbH, Oberes Ried 1, 6833 Klaus, Austria, +43 59495

Preface

CPC 100 User Manual





About this user manual

Since the scope of this User Manual is confined to the most important information about a specific subject, the CPC 100 User Manual complements the CPC 100 Reference Manual, however, it does not replace it. The CPC 100 Reference Manual is available in PDF format on the *Primary Test Manager* DVD and the *CPC 100 Start Page*.

Reading the CPC 100 User Manual alone does not release the user from the duty of complying with all national and international safety regulations relevant for working with the *CPC 100*, for example, the regulation EN50191 "Erection and Operation of Electrical Test Equipment" as well as the applicable regulations for accident prevention in the country and at the site of operation.

Conventions and symbols used

In this manual, the following symbols indicate safety instructions for avoiding hazards.

	DANGER Death or severe injury will occur if the appropriate safety instructions are not observed.
	WARNING Death or severe injury can occur if the appropriate safety instructions are not observed.
	CAUTION Minor or moderate injury may occur if the appropriate safety instructions are not observed.
	NOTICE Equipment damage or loss of data possible

Safety instructions for the *CPC 100* and its accessories

The *CPC 100* must be used in observance of all existing safety requirements from national standards for accident prevention and environmental protection. Before operating the *CPC 100*, read the following safety instructions carefully. Do not turn on or use the *CPC 100* if you do not understand the information in this manual. If any of the safety instructions are unclear, contact OMICRON.

Principle use according to regulations

- ▶ Use *CPC 100* and its accessories only in a technically sound condition.
- ▶ Make sure its use is in accordance with the regulations on site and the designated use described in this document.
- ▶ Comply with the workflows described in this document. Avoid interruptions or distractions that could affect safety.
- ▶ The *CPC 100* is exclusively intended for the application fields specified in detail in "Designated use" on page Preface-2. The manufacturer/distributor is not liable for damage resulting from improper usage.
- ▶ Follow the instructions provided in this User Manual and in the CPC 100 Reference Manual available in PDF format on the *Primary Test Manager* DVD and the *CPC 100 Start Page*.
- ▶ Do not open the *CPC 100* housing.
- ▶ If you do not use the *CPC 100* anymore, turn the key to "lock" (vertical) and remove the key to avoid anybody accidentally turning on the *CPC 100*.
- ▶ Store the key and the *CPC 100* separately to prevent unauthorized personnel from using the *CPC 100*.
- ▶ If you have a cardiac pacemaker, do not use the *CPC 100*. Before operating the *CPC 100*, make sure there is no person with a cardiac pacemaker in the immediate vicinity.

Orderly measures

- ▶ This User Manual only complements the CPC 100 Reference Manual available in PDF format on the *Primary Test Manager* DVD and the *CPC 100 Start Page*. However, it does not replace it.
- ▶ Either this User Manual or the CPC 100 Reference Manual should always be available on the site where the *CPC 100* is being used.
- ▶ Personnel assigned to use the *CPC 100* should carefully read the CPC 100 User Manual/ Reference Manual - in particular the section on safety instructions - before beginning to work with it. On principle, this also applies to personnel who only occasionally work with the *CPC 100*.
- ▶ Do not undertake any modifications, extensions, or adaptations to the *CPC 100*.
- ▶ Use the *CPC 100* in conjunction with original accessories only.

Operator qualifications and primary responsibilities

Only authorized personnel who are qualified, skilled and regularly trained in electrical engineering are allowed to operate the *CPC 100* and its accessories. Personnel receiving training, instructions, directions, or education on *CPC 100* must be under constant supervision of an experienced operator while working with the equipment. The supervising operator must be familiar with the equipment and the regulations on site.

Safe operation

If the equipment is used in a manner not described in the user documentation, the protection provided by the equipment may be impaired.

When putting the *CPC 100* into operation, follow the instructions in section "Putting CPC 100 into Operation" in the CPC 100 Reference Manual (available in PDF format on the *Primary Test Manager* DVD or the *CPC 100 Start Page*).

- ▶ Never use the *CPC 100*, any accessory or the *CP TD* equipment trolley without a solid connection to earth with at least 6 mm².
- ▶ Use a ground point as close as possible to the operator.

Designated use

The *CPC 100*, in conjunction with its accessories or as a stand-alone unit, is a multi-purpose primary test set for commissioning and maintaining substation equipment. It performs current transformer (CT), voltage transformer (VT) and power transformer (TR) tests. Furthermore, it is used for contact and winding resistance testing, polarity checks as well as primary and secondary protection relay testing.

The various, partly automated tests are defined and parameterized via the front panel control of a built-in embedded PC.

The functionality scope of the *CPC 100* is described in detail in the chapter "Designated Use" of the *CPC 100 Reference Manual* available in PDF format on the *Primary Test Manager DVD* or the *CPC 100 Start Page*.

Note: Any other use of the *CPC 100* but the one mentioned above is considered improper use, and will invalidate all customer warranty claims and exempt the manufacturer from any liability to recourse.

FOR YOUR OWN SAFETY

Always follow the 5 safety rules:

1. Disconnect completely.
2. Secure against re-connection.
3. Verify that the installation is dead.
4. Carry out grounding and short-circuiting.
5. Provide protection against adjacent live parts.

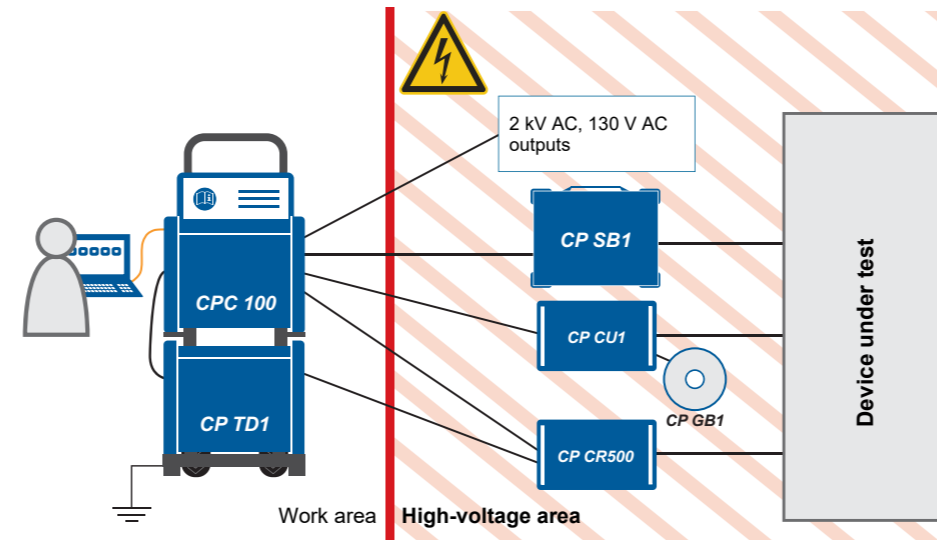

Safety instructions for the *CPC 100* and its accessories

Example of the separation of work area and high-voltage area using different OMICRON devices:



- ▶ Do not enter the high-voltage if the red status light of the *CPC 100* is on.

Safety symbols on the device

-  Caution, possibility of electric shock
-  Caution

General

The *CPC 100*'s outputs and the cables connected to them carry life-hazardous voltage or current.

- ▶ Always obey the five safety rules and follow the detailed safety instructions below.
- ▶ Before connecting or disconnecting test objects and/or cables, turn off the *CPC 100* by pressing the **POWER ON/OFF** switch. Then press the **Emergency Stop** button.
- ▶ Never connect or disconnect a test object while the outputs are active.
- ▶ Make sure that a test object's terminals that are to be connected to the *CPC 100* do not carry any voltage potential. During a test, the only power source for a test object may be the *CPC 100*.
- ▶ At their output sockets and especially in the cables connected to them, in operation the high-current outputs **400A DC** and **800A AC** generate a significant amount of heat (approx. 300W/m at 800A). To prevent burns, use gloves when touching the cables while in operation or a short while after.
- ▶ Do not insert objects (e.g., screwdrivers, etc.) into any input/output socket.
- ▶ Never use the test cards **Quick** and **Resistance** to measure the resistance of windings with a high inductance because turning off the DC source results in life-threatening voltage levels. For this kind of measurement only use either the special winding resistance test card **RWinding** or the test card **TRTapCheck**.
- ▶ When measuring the ratio of voltage and power transformers make sure that the test voltage is connected to the corresponding high-voltage winding, and the voltage of the low-voltage winding is the one that is measured. Accidentally mixing up the windings can generate life-threatening voltages within the transformer.

Safety Instructions for the CPC 100 and its accessories

- ▶ Make sure that when testing a current transformer by feeding a test current into its primary winding, all secondary windings are shorted. On open secondary windings, life-threatening voltages can be induced.
- ▶ Connect only one CPC 100 output at a time.
- ▶ All AC and DC output sockets of the CPC 100 can carry life-hazardous voltage potential and provide life-hazardous currents. Therefore:
 - ▶ While connecting cables to the CPC 100 high-voltage or current outputs, or other conducting parts that are not protected against accidental contact, press the Emergency Stop button, and keep it pressed as long as an output signal is not absolutely necessary for the test.
 - ▶ When connecting to the front panel input/output sockets, use wires with either 4 mm safety “banana” connectors and plastic housing or, where applicable, with the especially manufactured counterpart supplied by OMICRON (e.g., for the **V2 AC** measuring input).
 - ▶ For the high-voltage and current output connectors on the left-hand side of the test set (2kV AC, 400A DC and 800A AC, Ext. Booster), only use the specially manufactured cables supplied by OMICRON (refer to the chapter “Accessories” of the CPC 100 Reference Manual available on the *Primary Test Manager* DVD or the *CPC 100 Start Page*).
 - ▶ One end of the high-voltage cable has a coaxial safety plug that is certified for a voltage level of 2kV AC. The other end is equipped with a safety banana plug that is insulated with a shrink tube. When the CPC 100 is switched on, consider this part of the cable a hazard of electric shock.
 - ▶ If you do not use the high-current outputs **400A DC** or **800A AC**, or the high-voltage output **2kV AC**, disconnect any cable that may be plugged in to these sockets.

Note: The 400A DC or 800A AC outputs are not switched off by internal relays. Therefore, if a test mode is selected that does not use either one of these two outputs, they still generate current.

- ▶ Do not stand right next to or directly underneath a connection point because the clamps may fall off and touch you.
- ▶ The red status light on the CPC 100 front panel indicates hazardous voltage and/or current levels at the CPC 100 outputs (red light “I” on or flashing). The green status light indicates that the CPC 100 outputs are not activated.

Note: If none or both status lights are on, the unit might be defective. Contact OMICRON Support.

- ▶ Both of the high-current output sockets on the left-hand side of the test set (**400A DC** and **800A AC**) usually carry a relatively low-voltage potential. However, in case of an internal insulation fault these outputs may carry up to 300 V. Consider these outputs life-hazardous.
- ▶ Always lock connectors properly.



The counterpart of the high-current sockets are locking connectors.

To lock these connectors safely, insert them carefully until you feel a “click” position. Now they are locked. Confirm this by trying to pull them out. This should not be possible now.

To remove the locking connectors, unlock them by pushing them in completely first, and then pull them out.

- ▶ The high-current cables for both the **800A AC** and **400A DC** outputs are equipped with connection clamps at one end. If these connection clamps are attached to a test object’s terminal that is situated above your head, make sure the clamp is securely attached. Due to the weight of the cables the clamp may become loose and fall down.
- ▶ Do not operate the CPC 100 under ambient conditions that exceed the temperature and humidity limits listed in “General” on page Technical Data-3.
- ▶ Do not operate the CPC 100 in the presence of explosives, gas or vapors.

- ▶ If the CPC 100 or any add-on device or accessory does not seem to function properly, do not use it anymore. If in doubt, contact OMICRON Support. (refer to cover page of this User Manual).

Grounding

Operating the device without PE and ground connection is life-threatening and not permitted.

- ▶ Only operate the CPC 100 with a mains power supply connected to protective earth (PE).
- ▶ Make sure that both the PE connection of the power supply and the ground connector of the CPC 100 have a solid and low-impedance connection to the grounding system on site. This also applies to all other test devices and accessories in the test setup.
- ▶ Make sure that the grounding clamp has a good electrical contact to the grounding system on site and avoid connecting it to corroded or painted surfaces.
- ▶ Make sure that the grounding terminal connections of all grounded devices in use remain intact during the whole measurement procedure, and are not accidentally disconnected.

Only use ground and supply cables provided by OMICRON.

Safety Instructions for the *CPC 100* and its accessories

Power supply

Operating the *CPC 100* without PE and ground connection is life-threatening and not permitted.

- ▶ Only operate the *CPC 100* with a mains power supply connected to protective earth (PE).

Power supply from grounded grids (TN/TT)

Before a measurement is started, the *CPC 100* automatically verifies the PE connection in grounded grids (TN/TT).

- ▶ If this check fails, check the power cord and power supply.

If the error message persists, there is no intact connection to protective earth (PE).

This is life-threatening. In this case measurements are not permitted and cannot be performed.

Power supply from isolated grids (IT)

An IT grid is a grid structure where none of the active conductors are galvanically connected to ground. In an IT grid, only the PE is connected to ground.

In IT grids, the check fails – even if there is a PE connection. This can be the case when the *CPC 100* is powered by a generator. Since every operation mandates a PE connection for the operation of the *CPC 100*, you need to manually verify this.

If the *CPC 100* is supplied by a generator, the equipotential ground or PE of the generator has to be grounded properly.

- ▶ If this is not possible, measurements are not permitted and cannot be performed.

Additional information

Instead of supplying the *CPC 100* from phase-neutral (L1-N, A-N), it may also be supplied from phase-phase (for example, L1-L2; A-B).

- ▶ Make sure that the voltage does not exceed 240V AC.
- ▶ Make sure that the power supply is fuse-protected (16 A automatic circuit breaker).
- ▶ Do not use an extension cable on a cable reel to prevent an overheating of the cord; run out the extension cord.
- ▶ Keep extension cables as short as possible to prevent power loss.

If the power supply is $\leq 190V$ AC, the *CPC 100* cannot provide the full output power at the **800A AC** output. The same applies when an external current booster is used.

- ▶ Therefore, in order to gain the full output power, provide a sufficient power supply (190 V ... 240 V AC).

The **Ext. Booster** connector is **always** galvanically connected to mains and active.

This also applies when no external booster is selected, the green status light (0) is on, the outputs are turned off, or the Emergency Stop button is pressed.

- ▶ Handle the **Ext. Booster** connector with extreme caution.
- ▶ Only use booster cables supplied by OMICRON.
- ▶ Do not use booster cables that are frayed or damaged in any way.

Changing fuses

1. Ground the test object, and disconnect it from the *CPC 100*. By disconnecting it, you prevent a possibly faulty test object feeding power back into the *CPC 100*.
2. Turn off the *CPC 100* and unplug the power cord. Then press the **Emergency Stop** button. Wait for about 30 seconds. This time is necessary for the internal electrolytic capacitors to fully discharge.
3. Locate the blown fuse on the front panel of the *CPC 100*, and replace it.

Note: Replace with identical fuse type only (refer to the chapter “Changing Fuses” of the *CPC 100 Reference Manual* available in PDF format on the *Primary Test Manager* DVD or the *CPC 100 Start Page*).

DC output to test objects with a high inductance

- ▶ Only use the dedicated test cards for DC measurements on assets with inductive characteristics:

CPC 100 test cards	Primary test manager tests
RWinding	DC Winding Resistance
D-OLTC-Scan	Dynamic OLTC Scan
Demagnetization	Demagnetization
TRTapCheck	CT Winding Resistanc Sec
	DC Winding Resistance Stator
	DC Winding Resistance Rotor

- ▶ Never open the measuring circuit while current flows.
- ▶ After a measurement, wait until the test device has discharged completely.
- ▶ Ground all terminals of the test object before touching the test setup.

Safety Instructions for the CPC 100 and its accessories

- ▶ Short-circuit the terminals before disconnecting the test leads.
- ▶ Disconnect cables not used for testing both from the test object and the test device.

Discharging after tests on objects with a high inductance

After a winding resistance measurement, the CPC 100 monitors the reduction of the current and voltage levels to zero. During this discharge process, the red status light flashes.

In the **Demag** test card, the discharging process is displayed as a status message (see "Demagnetization" on page 10).

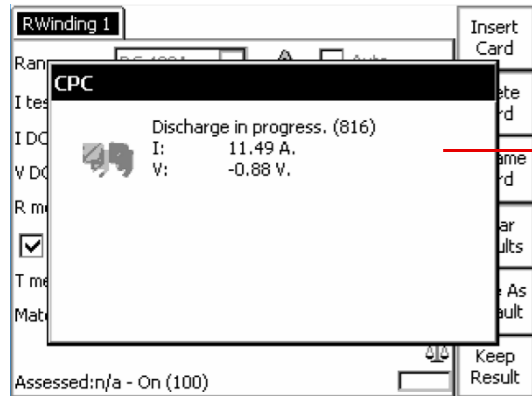

In all other affected tests, the discharge progress is displayed in a dialog.

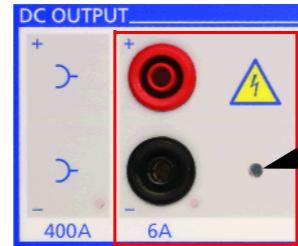

LED steady-on red: voltage on **6A DC** output > 2 V

Note: This indicator only applies to the **6A DC** output and does *not* include the **400A DC** output.

Note: When you disconnect a cable during the discharge process, even low voltage presents considerable danger as it suddenly increases to a very high level when the circuit is disconnected.

- ▶ Do not touch or disconnect any part of the test setup until the current and voltage levels have reduced to zero.
- ▶ If the measurement is interrupted due to, for example, an unexpected loss of supply voltage or erroneous behavior of the CPC 100 do not touch the test setup until the energy has dissipated over time.
Note that the length of time depends heavily on the asset under test.

CPC 100 in combination with the CP TD

The CP TD (CP TD1, CP TD12 and CP TD15) is an optionally available high-precision test system for on-site insulation tests of high-voltage systems like power and measuring transformers, circuit breakers, capacitors and isolators. The CP TD works as an add-on device to the CPC 100 and is described in chapter "CP TD" of this User Manual.

On principle, the safety instructions that apply to the CPC 100 and its accessories also apply to the CP TD. However, the CP TD requires some additional precautions and measures. They are listed in chapter "CP TD" on page CP TD1-1.

Declaration of Conformity

Declaration of Conformity (EU)

The equipment adheres to the guidelines of the council of the European Community for meeting the requirements of the member states regarding the electromagnetic compatibility (EMC) directive, the low voltage directive (LVD) and the RoHS directive.

FCC Compliance (USA)

This equipment has been tested and found to comply with the limits for a Class A digital device, pursuant to part 15 of the FCC Rules. These limits are designed to provide reasonable protection against harmful interference when the equipment is operated in a commercial environment. This equipment generates, uses, and can radiate radio frequency energy and, if not installed and used in accordance with the instruction manual, may cause harmful interference to radio communications. Operation of this equipment in a residential area is likely to cause harmful interference in which case the user will be required to correct the interference at his own expense.

Changes or modifications not expressly approved by the party responsible for compliance could void the user's authority to operate the equipment.

Declaration of Compliance (Canada)

This Class A digital apparatus complies with Canadian ICES-003.

Cet appareil numérique de la classe A est conforme à la norme NMB-003 du Canada.

Recycling



This test set (including all accessories) is not intended for household use. At the end of its service life, do not dispose of the test set with household waste!

For customers in EU countries (incl. European Economic Area)

OMICRON test sets are subject to the EU Waste Electrical and Electronic Equipment Directive 2012/19/EU (WEEE directive). As part of our legal obligations under this legislation, OMICRON offers to take back the test set and ensure that it is disposed of by authorized recycling agents.

For customers outside the European Economic Area

Please contact the authorities in charge for the relevant environmental regulations in your country and dispose the OMICRON test set only in accordance with your local legal requirements.

Cleaning

- ▶ Do not clean *CPC 100* or any other device when connected to the test object.
- ▶ Disconnect the test object, accessories and connection cables before cleaning.
- ▶ Use a cloth dampened with isopropanol alcohol to clean *CPC 100* and its accessories.

Introduction

Functional components of the CPC 100

I / O status lights

Status lights that indicate the operational status of the CPC 100 outputs. The green light "0" indicates that the current/voltage source is off while the red light "I" indicates that the current/voltage source is active and/or a measurement process is running.

- Key lock**
Locks front panel operation.
- BIN IN**
Binary trigger input, wet or dry contact
- IAC/DC INPUT**
Fuse-protected with a 10A very quick-acting fuse
- Fuse 6.3A T (slow-acting wire fuse 5x20 mm)**
for 3A AC, 6A AC, 130V AC and 6A DC
- AC OUTPUT**
6A, 3A or 130V output
- Fuse 3.15A (slow-acting wire fuse 5x20 mm)**
for 3A AC and 130V AC
- V1 AC input** — **V2 AC input**
300V AC input — 3V AC input
- DC OUTPUT**
6A DC output (fuse-protected with a 6A fuse)
- VDC INPUT**
10V DC input or 2-wire resistance
- Emergency Stop button**
Immediately shuts off all outputs (could leave transformer in saturation).

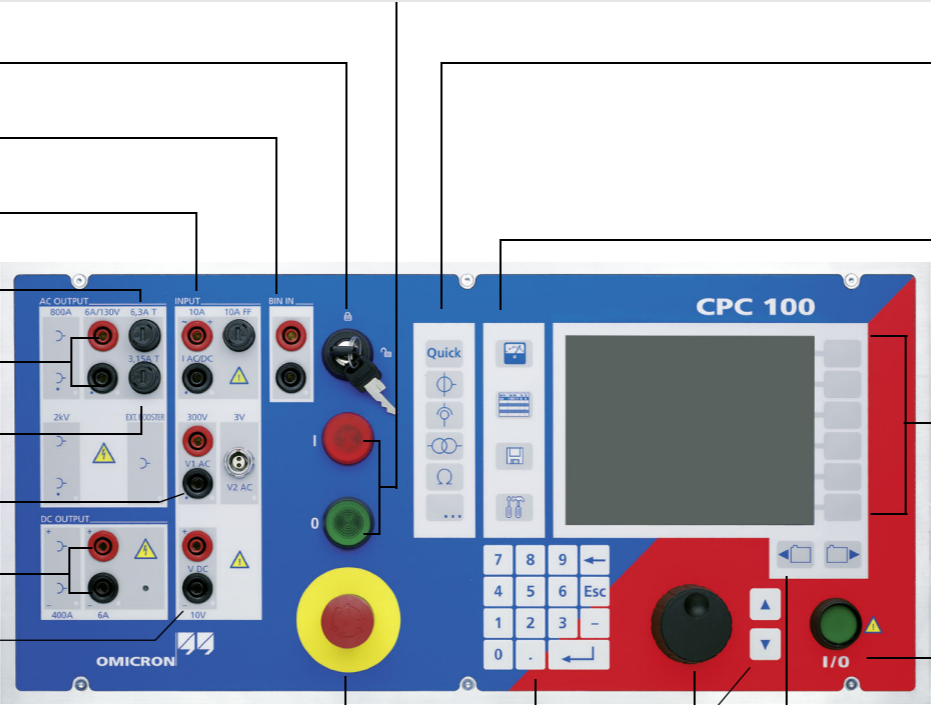

- Add test cards**
We recommend not to use more than 15 test cards or 50 test results in one test procedure.
- Test Card View:** View to set up test cards, compose test procedures, enter test settings, define test cards or the test procedure default, start tests etc.
- Test Procedure Overview:** Provides an enhanced overview of all test cards of the currently active test procedure. Defines the test procedure default.
- File Operations:** Lets you save, load, delete, copy and rename test procedures.
- Options:** To specify general parameters.
- Context-dependent menu keys**
Directly invoke specific commands associated with the currently selected control of the test card and view.
- I/O**
Use to start and stop a test.
- Tab selector**
To change between the single test cards of a test procedure.

Functional components of the CPC 100

Emergency Stop button

Pressing the Emergency Stop button *immediately* shuts off all current and voltage outputs except for the **Ext. Booster** output.

A running test is terminated, the software does not accept any more entries and/or commands.

Once the reason for the Emergency Stop is cleared and the Emergency Stop button released, the test can be re-started by pressing the **I/O** (test start/stop) push-button while in Test Card View.

DANGER

Death or severe injury caused by high voltage or current

The **Ext. Booster** connector is **always** galvanically connected to mains.

- ▶ Handle the **Ext. Booster** connector with extreme caution.
- ▶ Do not use any other booster cables than the ones supplied by OMICRON electronics.
- ▶ Do not use booster cables that are frayed or damaged in any way.

WARNING

Death or severe injury caused by high voltage or current possible

Stopping a test does not shut off the **CPC 100** outputs instantaneously. First, the currently running test sequence finishes, then the test execution is stopped. Most test cards finish the running test sequence with a predefined ramp function.

- ▶ Therefore, in a hazardous situation never press "Stop Test".
- ▶ Instead, use Emergency Stop.

High-voltage and current outputs

When the **CPC 100** outputs high current, observe the allowed duty cycles that may apply to the selected AC output range.

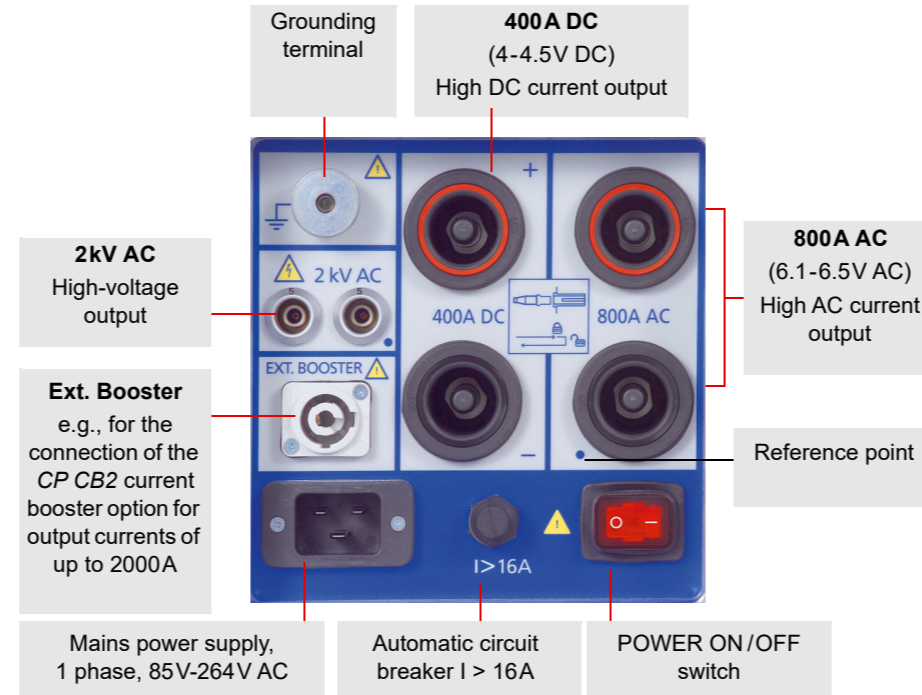

ePC interfaces¹

RJ45 socket for connecting **CPC 100** to a PC or a network hub

USB connector for connecting OMICRON electronics USB memory sticks

Serial interface connector for connecting optional CP TD test set

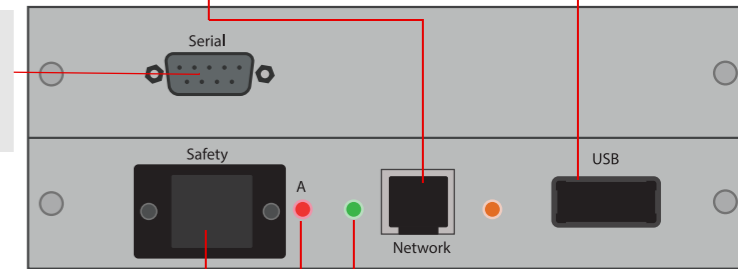

Connector for external safety functions

Red LED

Green LED

1. For detailed information on the RJ45 connectors, see chapter "CPC 100 in a Network" in the CPC 100 Reference Manual available in PDF format on the *CPC 100 Toolsets* or *CPC 100 Start Page*.
2. For the pin assignment of the RS232 serial interface plug, refer to the CPC 100 Reference Manual, section "ePC Interfaces" of chapter "Technical Data".
3. The connector for external safety functions allows connecting safety accessories for the **CPC 100**. The attached plug contains a jumper, and as long as it is placed on the connector, the circuit is bridged. If the plug is removed, the emergency stop is active.

For the plug's pin assignment and a wiring scheme, refer to section "Connector for External Safety Functions" of chapter "Technical Data" in the CPC 100 Reference Manual.

1. Older **CPC 100** versions have slightly different ePC interfaces. For detailed information refer to the CPC 100 Reference Manual.

CPC 100 block diagram

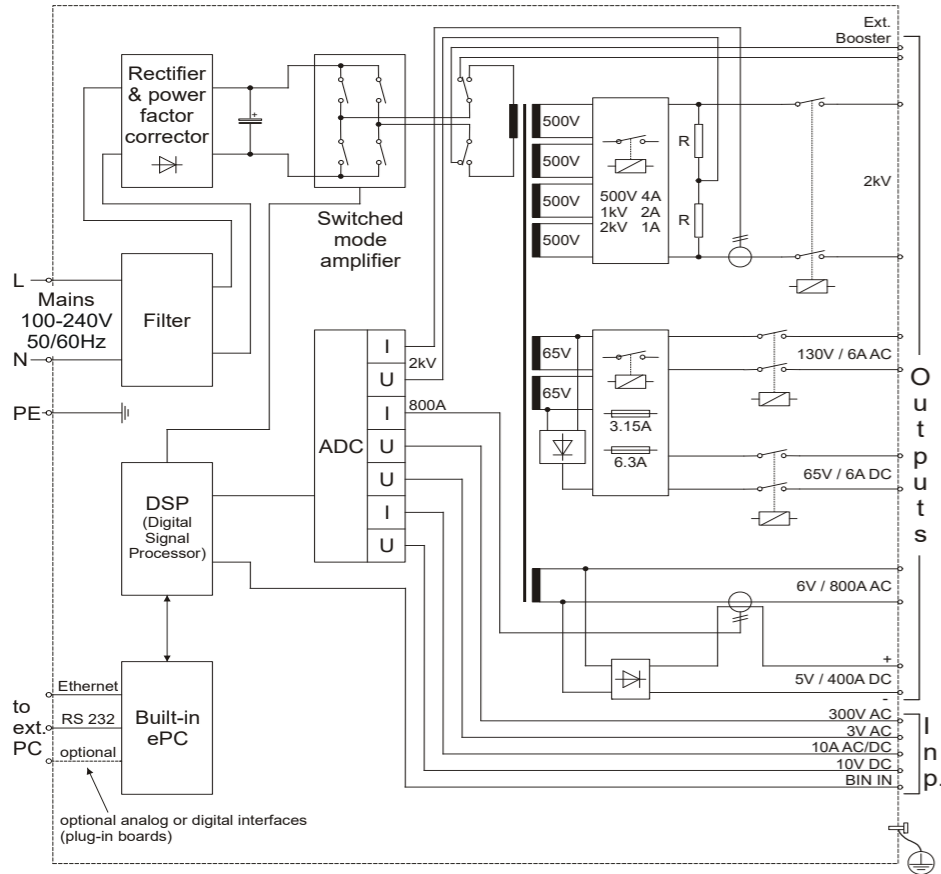

Principles of test cards and test procedures

Test cards

The *CPC 100* software comprises a number of test cards. A test card carries out one specific test, e.g., measuring a CT excitation curve, or testing the ratio of a voltage transformer.

A test card holds a number of user-definable test settings and - after the test was run - test results.

Test procedure

A test procedure contains multiple test cards.

The composition of such a test procedure and the settings of all single test cards can be freely defined by the user. Within a test procedure, each test card and its associated test is executed individually in a user-defined order.

Report

For archiving or reporting purposes, or later processing, a test procedure with all of its test cards, specific settings and - after the test was run - test results and assessments can be saved. It is then considered a report.

Such a report can later be opened any time in the *CPC 100*'s **File Operations** menu.

Note: For detailed information about test cards, test procedures and templates, refer to section "How to Use The *CPC 100* Software" of chapter "Introduction" in the *CPC 100* Reference Manual available in PDF format on the *CPC 100* Toolsets or *CPC 100* Start Page.

The components of a test card

Focus on the data entry field for AC current.

The term "focus" designates the currently selected (active) part of the test card. The selected component is highlighted or inverted.

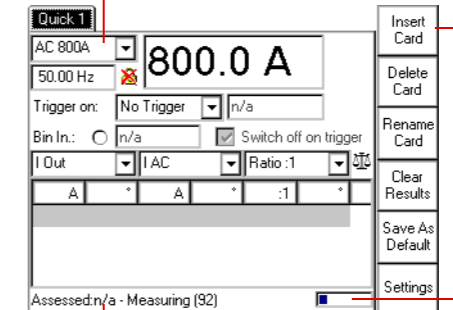

The actual function of the context-dependent menu keys depends on the selected view, test mode, test card and selected test card component (i.e., the focus).

Temperature and power consumption monitoring. If an output is activated, both the *CPC 100*'s power consumption and the current emitted at the high-current outputs is monitored and, together with the temperature, displayed by this temperature gauge. The temperature gauge's bar therewith represents an indicator for the remaining time the *CPC 100* can output power.

plenty of spare
 no more spare

Status of test assessment. The test assessment is a manual procedure carried out by the user. After the test, set the focus on the assessment symbol. Use the context-dependent menu key **OK** or **Failed** to assess the test.

For a few seconds, the status line also displays general operation information, e.g. "Emergency key pressed".

Pressing the **Settings** menu key opens the **Settings** page (see page Quick-1) allowing you to set the test cards individually. As a rule, do not set the test cards on the **Settings** page but set all test cards of a test procedure using the **Device Setup** tab in the **Options** view (see page Introduction-5).

Test procedure overview

Name	Date/Time	Res.	Assess.	
Quick	11/3/01 9:37:51	No	n/a	Insert Card Delete Card Save As Default Clear Results Clear All Results New Test
Comment	11/3/01 9:37:56	No	n/a	
CTRatio	11/3/01 9:47:05	Yes	OK	
CTBurden	11/3/01 9:47:02	Yes	OK	
CTExcitation	11/3/01 9:46:59	Yes	OK	
VWithstand	11/3/01 9:46:54	Yes	OK	

Type: Comment
Filename: CPC100\CTL1.xml

The Test Procedure Overview lists all test cards of the currently active test procedure in a list box showing the card's name, its creation date and time, whether test results are available and the test card's assessment status.



With **Save As Default**, Test Procedure Overview provides a function to save the current test procedure as the test procedure default, i.e., that default the *CPC 100* software will start with in future.

Note: For detailed information refer to section "Test Procedure Overview" of chapter "Introduction" in the *CPC 100 Reference Manual* available in PDF format on the *CPC 100 Toolsets* or *CPC 100 Start Page*.

The *CPC 100* file system

The highest hierarchical level of the *CPC 100* file system, the "root", is named **CPC 100**. Below this, you can create additional folders in a tree-structure of your choice, save tests in these folders, and perform file operations, such as open, save, rename, copy, paste etc.

File >
Edit >
Save Test
Save Test As
Open
New Test

Filename: CPC 100\lastmeas.xml

The *CPC 100* file system differentiates two file types:



name.xml A test procedure with all of its test cards and specific settings. An .xml file may also contain test results and assessments that were stored together with the settings as report in the *CPC 100* file system for archiving purposes.



name.xmt Test procedure template, i.e., a user-defined template containing one or more test cards with all of their specific test settings but without test results.

Note: The file containing the up-to-date measurements should be saved regularly. If the test unit is switched off, or in case of a power outage, all unsaved measurements will be lost.

► Long-press the **File operations** button to save the currently open test.

Navigating through the file system

Select a test or a folder using the handwheel or the **Up / Down** keys. To expand a collapsed folder tree , select it and press either the handwheel or **Enter**.

The menus

Main file operations menu

Opens the submenu **File** (refer to "Submenu File" on page 5)

Opens the submenu **Edit** (refer to "Submenu Edit" on page 5)

Saves the currently open test, i.e., the test card(s) previously opened in the Test Card View (refer to Note below).

Opens the **String Editor**. You can save the currently open test under a new name of your choice (15 characters max.).

Use the handwheel or the **Up / Down** keys to select a test, and press **Open** to open it. Changes to Test Card View.

Closes the current test card(s), changes to Test Card View and opens the test procedure default.

File >
Edit >
Save Test
Save Test As
Open
New Test

The CPC 100 file system

Note: Unlike the other menu items, the two **Save...** functions of the main **File Operations** menu directly effect the currently open test, i.e., the test procedure that was composed in the Test Card View, or the test that was loaded in the *CPC 100* file system beforehand.

Therefore, pressing **Save**, for example, does not save the test that you may have highlighted in the folder tree, but the one that is currently open.

Submenu File

Opens the **String Editor**. You can create a new folder with any name of your choice.

Appends the contents of a test file (.xml) or template (.xmt) of your choice to the currently open test.

Deletes the currently selected test or folder from the *CPC 100*'s disk space.

Opens the **String Editor** that enables you to rename the current test to any new name of your choice.

(for future use)

Closes the submenu and returns to the main **File Operations** menu.

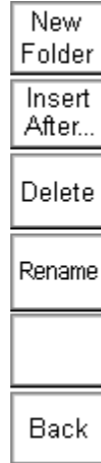

Submenu Edit

Select the test of your choice. Press **Cut** to put the selected test or folder to the Clipboard. Proceed with **Paste...**

Select the test of your choice. Press **Copy** to copy test or folder to the *CPC 100* clipboard. Proceed with **Paste...**

Move to the destination folder of your choice. Press **Paste** to insert the contents of the *CPC 100* clipboard to this folder.

Press **Paste As Templ.** to make the contents of the *CPC 100* clipboard a test procedure template.

(for future use)

Closes the **Edit** submenu and returns to the main File Operations menu.

Note: If a folder is cut or copied to the Clipboard, the selection is recursive, i.e., all of its subfolders will also be put to the Clipboard.

Cutting or copying a test or folder, and trying to paste it in the same location, opens the **String Editor**.

Since a test or folder cannot exist twice under the same name at the same location, determine a new name for it using the **String Editor**.

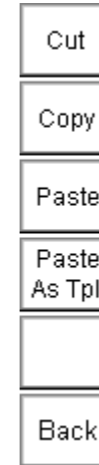

The Options menu

Device setup

Set the external booster you want to use.

Set current clamp parameters and CT and/or VT transformation ratio.

Set the default frequency. This value will be used for all test cards.

Auto save automatically saves the current test settings in fixed intervals specified to a file named *lastmeas.xml*.

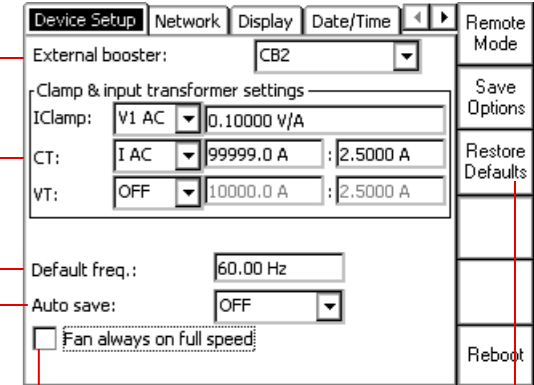

Resets all user-specific settings made in the *CPC 100* software to factory-defined defaults including:

- the test card defaults
- the test procedure default
- all settings made at the **Device Setup** tab (Sets external booster to CB2, sets CT and VT to "OFF" and sets the default frequency to 50 Hz.)
- the String Editor's template strings

If selected, the CPC 100 cools down faster. Thus, the duty cycle can be increased.

The Options menu

Network

Set the communication parameters.

DHCP / Auto-IP

Configures all communication parameters automatically; the DHCP server will do it for you or it will be done via the Auto-IP mechanism.

The data entry fields for IP address, Subnet Mask, Default Gateway and DNS are read-only, no data can be entered. This is the recommended setting.

Static IP

Configure the communication parameters manually by entering the values into the data entry fields using the soft-touch keys.

Activate/deactivate the sampled values stream communication.
This is a licensed feature for the SV-Ratio measurement, filtering IEC 61850 messages.

Display

Sliding regulator to adjust the display contrast.

Accessories

The **Accessories** tab comprises safety-relevant settings for the *CP TD*. The settings you choose in this view serve as a default for all corresponding test cards you set up afterwards.

Note: Per default and after start-up, the check boxes are activated.

1. Use beeper

If activated, the beeper sounds during the entire test. If cleared, the beeper sounds at the beginning and the end of the test only.

2. Perform shield check

The shield check verifies if both the high-voltage connector and the grounding terminal are connected to the *CP TD*. In certain cases, for example when strong interferences are present during testing or when compensating reactors (e. g. the *CP CR500*) are used, the shield check will prompt a false error message.

DANGER

Death or severe injury caused by high voltage or current

▶ Make sure that **both** the high-voltage connector and the grounding terminal are connected and that the cables and connectors are intact before deactivating the shield check.

3. Perform loop check

The loop check verifies the connection to the device under test. When measuring very low capacities, the resulting weak signal might cause the loop check to falsely state that no device under test is connected.

DANGER

Death or severe injury caused by high voltage or current

▶ Make sure that the device under test is connected and that all cables and connectors are intact before deactivating the loop check.

The Options menu

Synchronization

Synchronize up to two slave units (*CPC 100* or *CPC 80*) with a *CPC 100* configured as master unit for testing with the **Quick**, **Sequencer**, **Ramping** and **HV Resonance Test System** test cards.

Note: Synchronization requires the CPC Sync plug-in card and license, and the *TRC1*. *CPC 100 V0* devices cannot be used for synchronization.

Displayed on	Status
M1	Master Slave 1 synchronized
M2	Master Slave 2 synchronized
M	Master Both slaves synchronized with master
S	Slave Status OK

	Displayed on	Status
EV	Slave	CPC version mismatch
EO	Slave	Different outputs set on master and slave(s) ▶ Set the same outputs on all devices.
ES	All	No <i>TRC1</i> connected
EC	All	Sync cable(s) error/not connected

Available output ranges in the **Quick**, **Sequencer** and **Ramping** test cards with synchronized *CPC* devices:

- AC 800 A
- CB2 1000 A
- CB2 2000 A
- Output for customized matching transformer

Note: The output value depends on the number of synchronized *CPC* devices (for example: 3 *CPC* devices – max. output value: 800 A x 3 = 2400 A).

NOTICE Equipment damage possible

- ▶ When connecting devices in series, make sure that the insulation of the equipment housing can withstand the maximum applied voltage.
- ▶ Refer to the *CPC 100 Reference Manual* more information.

Date / Time

Set date and time.

Complete the steps below to set the system time:

- ▶ Put the focus onto the **Time:** field using the handwheel.
- ▶ Use the **Up/Down** keys to select between hours, minutes and seconds.
- ▶ Turn the handwheel to increase or decrease the value.
- ▶ Press the handwheel to acknowledge your entry.

Set system date.

The Options menu

Regional settings

Regional setting for language, temperature unit, date and time style. These settings affect the way the CPC 100 software displays and sort dates, times, numbers and decimal points.

System language	Language:	English	Up
Temperature unit: °C or °F	Temperature unit:	°C	Down
Distance unit: meters or miles	Distance unit:	meters	Enter
Define the display style for date and time	Date/Time Styles		Esc
	Date style:	yyyy-MM-dd	
	Time style:	HH:mm:ss	
			Back to Top

Service

During operation, the CPC 100 creates a log file with a user-definable logging level.

Date/Time	Regional Settings	Service	System Info	Up
Logging level:		Warning		Down
10:30:15 - SW VerSt		None		Clear Log
10:30:15 - SW VerSt		Error		Page
		Warning		
		Info		

We recommend to set the logging level to **Warning**.

System Info

Displays system information.

Regional Settings	Service	System Info	Remote Mode
Serial Number:	HA168L	Save Options	
OS Version:	Windows CE 4.20	Restore Defaults	
Software Version:	4.20 SR 2 (2024)		
Hardware:	CPC100-V1		
Memory information			
Free memory:	18436 KB		
Free disk space:	16828 KB		
			Reboot

Customizing Your Working Environment

1st Goal: Always loading certain test cards on system start-up



Fill out one or more test card(s) of your choice with the parameters you need.



Change to Test Procedure Overview.



Press **Save As Default**
You have now set the default for the CPC 100 start-up.

2nd Goal: Loading a certain test card with always the same values



Fill out the test card of your choice with the parameters you want to assign to that card.



Put the focus to the test card's tab.



Press **Save As Default**
You have now changed the default for this test card type.



The command **Restore Defaults** at the **Options** tab **Device Setup** resets all user-specific settings made in the CPC 100 software to factory-defined defaults. This includes the test card defaults and the test procedure default.

Accelerator keys

With the exception of **Quick**, pressing an accelerator key opens the corresponding **Insert a new test card** dialog box and lets you select the test card of your choice. Pressing **Quick** opens the **Quick** test card directly.

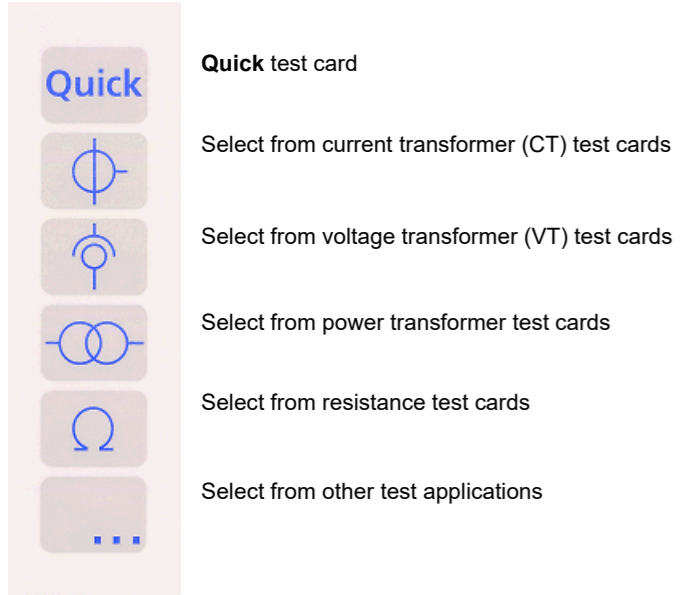

Quick

Quick is the most basic mode to operate all of the *CPC 100* outputs in a manual-like mode with front panel control.

Set output range

Set output value

Overload indication

Set frequency value or - if **Sync w/ V1 AC** is selected - phase angle.

1st measured quantity (including CT and VT)

2nd measured quantity (including CT and VT)

Measurement table showing results

AC 800A

800.0 A

50.00 Hz

Trigger on: No Trigger

Bin In.: n/a

I Out: I AC

Ratio: 1

A	*	A	*	:1	*
20.00m	n/a	70.00μ	n/a	285.71	n/a

Assessed: n/a

Insert Card

Delete Card

Rename Card

Clear Results

Save As Default

Settings

No indication: no overload
Dotted indication: an overload in the past
Solid indication: an overload now

Set the calculated value to be displayed in table below.
Depends on settings 1st and 2nd measured quantity.

Range

The output range combo box provides a list of available output ranges if the respective external booster was selected at the **Options** tab **Device Setup** or on the **Settings** page.

Settings page

Pressing the **Settings** menu key opens the **Settings** page. The **Settings** page with the exception of the **TRRatio** test card looks as shown below.

Settings

Quick 1

Booster model: CU1

Clamp & input transformer settings

IClamp: V1 AC 0.1000 V/A

CT: I AC 100.0 A : 2.5000 A

VT: V1 AC 600.0 V : 30.0000 V

Insert Card

Delete Card

Rename Card

Save As Default

Main Page

The **Settings** page allows setting the test cards individually. At the **Device Setup** tab in the **Options** view (see page Introduction-5), the same properties can be set for all test cards of a test procedure. As a rule, do not use the **Settings** page but the **Device Setup** tab in the **Options** view to set the test cards. Making different settings for the test cards is rarely a good idea. Set the test cards individually using the **Settings** page only in well-founded cases.

If a test card contains results, the settings cannot be changed. When a file containing results is loaded, the **Settings** page can be used to view the settings of the test procedure.

Measuring with Quick

- DANGER**
- Death or severe injury caused by high voltage or current**
- Together with the test object's capacitance, the leakage inductance of the *CPC 100*'s internal output transformer forms a series resonant circuit. Especially at frequencies > 50 / 60 Hz this may result in voltage super-elevation.
- ▶ When testing capacitive test objects using voltages ≥ 500 V, make sure that the test object's capacitance does not exceed 25 nF.
- DANGER**
- Death or severe injury caused by high voltage or current**
- ▶ Never use **Quick** in combination with a DC output on test objects with highly capacitive characteristics.
 - ▶ Mind the danger of test object's charged capacitance. Before connecting or disconnecting any leads, use a grounding/discharging rod
 - ▶ to discharge all terminals of the test object.
 - ▶ to connect all terminals of the test object to ground and short-circuit all capacitances.
- DANGER**
- Death or severe injury caused by high voltage or current**
- ▶ Never use **Quick** to measure the resistance of windings with highly inductive characteristics. Turning off the DC source results in life-threatening voltage levels.
 - ▶ For this kind of measurement only use the special winding resistance test cards **RWinding**, **TRTapCheck** or **OLTC-Scan**.

Measuring with Quick

If the output quantities of the selected output can be measured, the combo boxes “1st measured quantity” and “2nd measured quantity” provide **I Out** and / or **V Out** for selection.

I Out sel and **V Out sel** designate the frequency-selective measurement to filter out interferences as they usually occur in substations. The measured input is filtered according to the set output frequency.



After having set all necessary parameters, press the I/O (test start/stop) push button. The **Quick** test card enters the “on” state, the set power output value is switched to the *CPC 100*'s outputs, the measuring continues.



Pressing the **Quick** test card menu key **Keep Results** saves the currently measured values and “freezes” their display in the measurement table. Both the “measuring” and the “on” state remain active, the measurement continues in a new line of the measurement table.

Synchronizing output frequency with V1 AC

Sync w/ V1 AC



Set **Sync w/ V1 AC** by pressing the menu key that appears when the focus is on the frequency / phase angle data entry field.

This synchronizes the *CPC 100* output frequency with the **V1 AC** input frequency (we recommend a minimum input voltage of 10 V on **V1 AC**, possible range 48 - 62 Hz). In this case the phase angle of the output is displayed rather than the frequency. Set the phase angle value relative to the phase angle of the **V1 AC** input signal.



The icon next to the frequency / phase angle data entry field reflects the actual setting.

Due to the PLL (phase locked loop) technology, the synchronization with **V1 AC** takes places about 100 ms after the test was started.

Note: **Sync w/ V1 AC** is not available in all output modes.

Trigger settings

A trigger is the occurrence of a selected event, for example, a binary trigger is the first change of the state at the binary input.

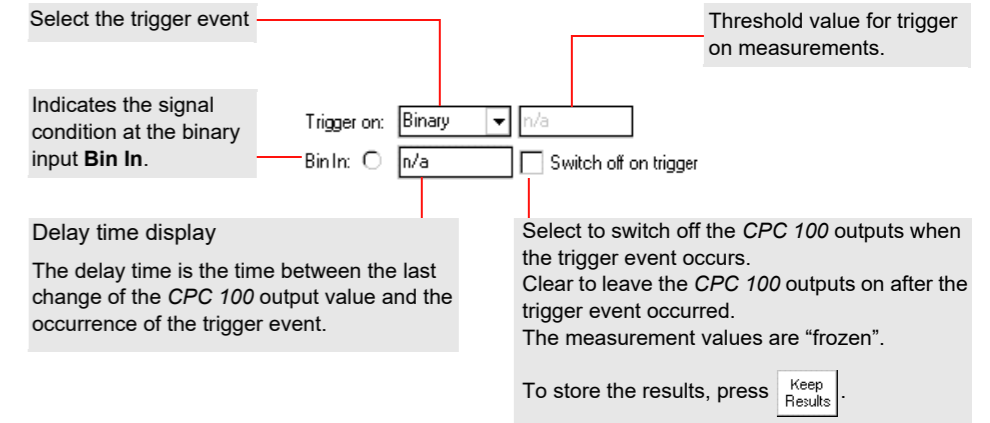

Note that some of the trigger events offered in the **Trigger on:** combo box depend on the measured quantity settings below (trigger on measurement).

Trigger on “Overload”: the occurrence or the clearing of an output overload condition (clearing is delayed by 100 ms to debounce).

Current transformer

CPC 100 User Manual

CTRatio (and Burden)

Use the **CTRatio** test card to measure a current transformer's ratio and burden with injection on the CT's primary side with up to 800 A from **AC OUTPUT**.

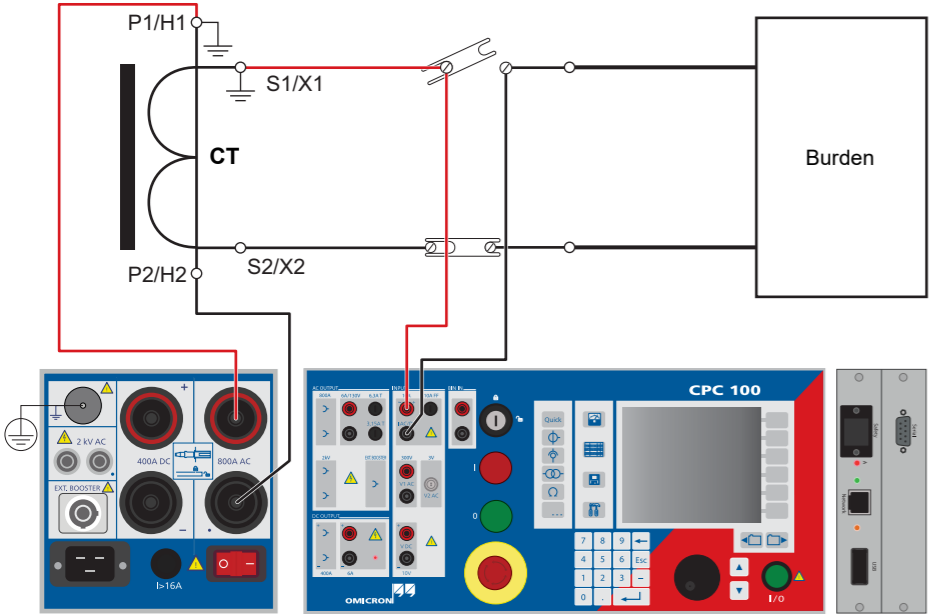

DANGER

Death or severe injury caused by high voltage or current

- ▶ When injecting current into the CT's primary winding, make sure that no secondary windings are open.

Nominal primary current

Output range

Select to stop test automatically when measurement is done.

Primary injection current

Nominal secondary current

Actual current injected into CT's primary side

Use current clamp rather than IAC input

Measured secondary current

Phase angle ϕ relative to I prim

Select to enter secondary current instead of measuring it

Ratio I prim. / I sec.:
I sec act x (I prim nom / I prim act)
and deviation in %
 $((K_n \times I_{sec} - I_{prim}) / I_{prim}) \times 100 \%$

Polarity:
OK = phase I sec - phase I prim
= $-45^\circ < 0^\circ < +45^\circ$
NOTOK = all other cases

See page Current Transformer-2

CTRatio (with Burden) - the Measure Burden option

Select the check box **Measure Burden** to measure the burden in VA.

Note: This option is only useful as long as the injected current I test is about of the magnitude of the nominal current I prim.

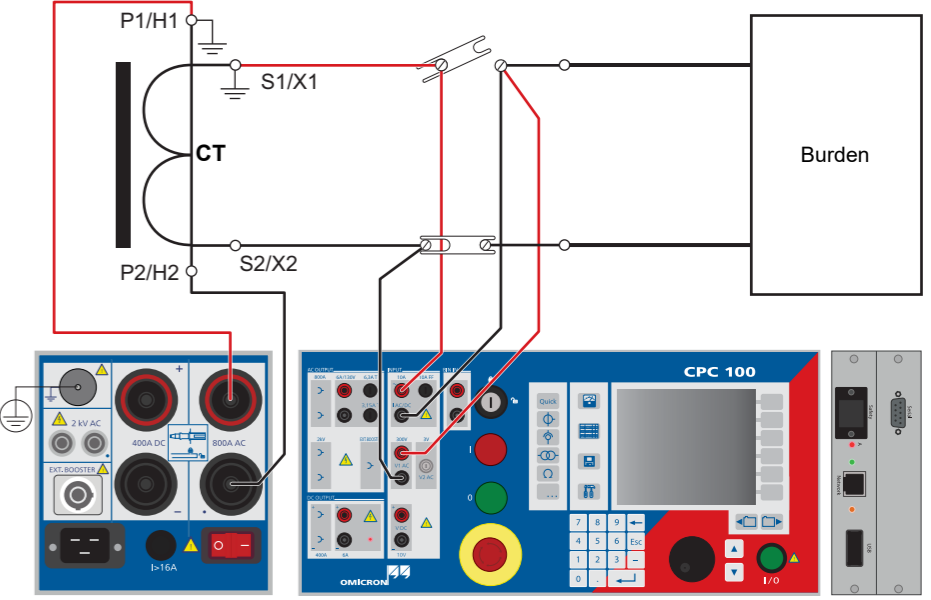

DANGER

Death or severe injury caused by high voltage or current

- ▶ When injecting current into the CT's primary winding, make sure that no secondary windings are open.

CTRatio (with Burden) - the Measure Burden option

Additional measurements when **Measure Burden** is selected:

CTRatio 1		CTRatio 2	CTBurden 1	CTExcita	Insert Card
Range:	AC 800A	<input checked="" type="checkbox"/> Auto			
I prim.:	200.0 A	I sec.:	5.000 A		
I test:	200.0 A	f:	50.00 Hz		
I prim.:	199.98 A	<input type="checkbox"/> Current clamp I sec.			
I sec.:	5.0120 A	0.15 °	<input type="checkbox"/> Manual input		
Ratio:	200.0:5.0125	0.250 %			
Polarity:	OK	<input checked="" type="checkbox"/> Measure burden			
V sec.:	1.7340 V	34.15 °	<input type="checkbox"/> Manual input		
Burden:	8.6492 VA	cos φ:	0.829		
Assessed:	n/a				
				Settings	

V sec: measured secondary voltage and phase angle relative to Iprim

Burden in VA: $I_{sec\ nom} \times (V_{sec\ act} \times I_{sec\ act} / I_{sec\ nom})$

cos φ: cosine of angle between I sec and V sec

Note: For the meaning of the other test card components, refer to page Current Transformer-1.

CTBurden

This is the preferred method in cases, when the current of max. 800 A that the CPC 100 can feed into the CT's primary side is not sufficient.

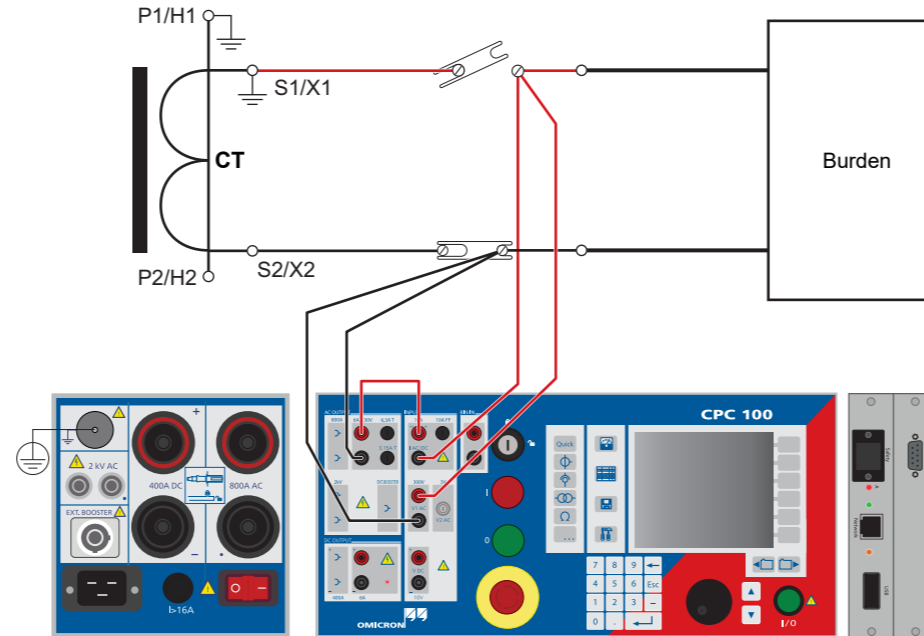

Secondary injection current from 6A AC output		Nominal secondary current		Select to stop test automatically when measurement is done.	
Output frequency		CTBurden 1		CTExcitation 1	CTRatioV 1
Actual injection current measured via input I AC		I sec.:	5.000 A	<input checked="" type="checkbox"/> Auto	Insert Card
Secondary voltage at the burden, measured at input V1 AC, and phase angle φ relative to Isec		I test:	5.000 A	Delete Card	
Burden in VA: $I_{sec\ nom} \times (V_{sec\ act} \times I_{sec\ act} / I_{sec\ nom})$		f:	50.00 Hz	<input checked="" type="checkbox"/> Auto	Rename Card
Cosinus of phase angle φ		I sec.:	5.0010 A	Clear Results	
		V sec.:	1.7340 V	30.15 °	<input type="checkbox"/> Manual input
		Burden:	8.6683 VA	cos φ:	0.865
		Assessed:	n/a	Save As Default	

Select to enter secondary voltage instead of measuring it

CTExcitation (knee point)

Use the **CTExcitation** test card to record the excitation curve of a current transformer. This test performs an automatic injection of a test voltage of up to 2 kV to the current transformer's secondary side.

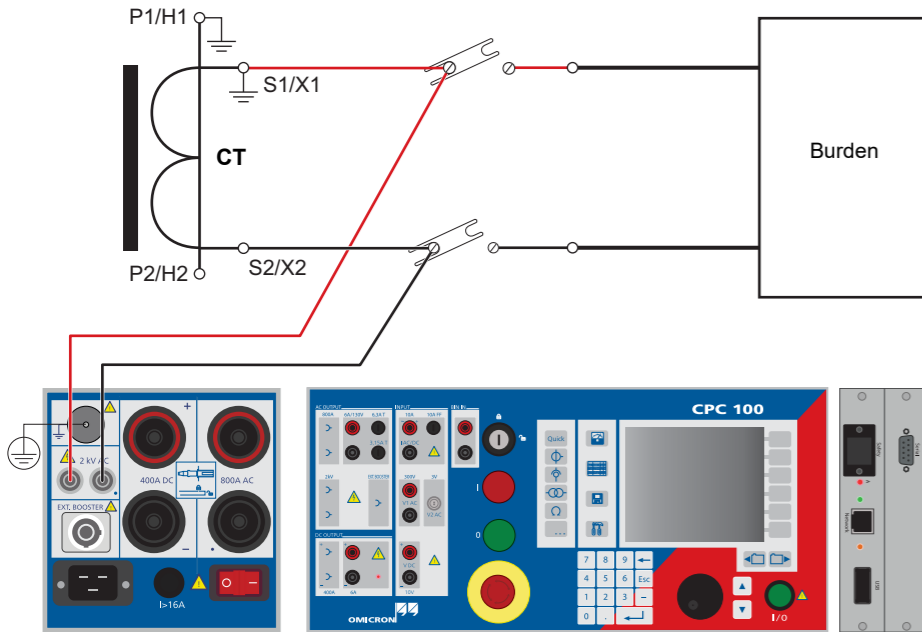

DANGER
 Death or severe injury caused by high voltage or current
 ▶ Do not touch tapped windings.

Maximum test current

Output frequency

Noise suppression

Actual voltage

Actual current

Maximum test voltage

Select to run test automatically. Pressing **Add Point** to add a test point to the graph does not work in Auto mode.

IEC/BS

ANSI 45°

ANSI 30°

According to IEC 60044-1, the knee point is defined as the point on the curve where a voltage increment of 10 % increases the current by 50 %.

According to IEEE C57.13, the knee point is the point where, with a double logarithmic representation, the tangent line to the curve forms a 45° angle. Applies to current transformer cores without an air gap.

Like ANSI 45° but forming a 30° angle. Applies to current transformer cores with an air gap.

DANGER
 Death or severe injury caused by high voltage or current

- ▶ On multi-tap CTs, only inject on the outer taps in order to avoid generating voltages higher than the test voltage.
- ▶ Make sure that no other secondary windings are open.

The graph displays the test results in form of an interpolated curve with test point markers. Turn the handwheel to set the focus onto the graph, and press it. This will bring up a crosshair cursor that lets you navigate through the list of test points by using the keys **Previous Point** and **Next Point**. Turning the handwheel has the same effect. The fields **V:** and **I:** display the value pair of each test point.

Noise suppression: Select if you see unsteadiness and jumps in the CT excitation curve. The unsteadiness or jumps can occur due to noise or disturbance during the measurement. If noise suppression is selected, the measurement is done with a different frequency.

If $f_{nom} \geq 60 \text{ Hz} \rightarrow f_{test} = f_{nom} - 10 \text{ Hz}$.

If $f_{nom} < 60 \text{ Hz} \rightarrow f_{test} = f_{nom} + 10 \text{ Hz}$.

The voltage will then be calculated back to f_{nom} ($V = V_{meas} * f_{nom}/f_{test}$). With $f_{nom} < 60 \text{ Hz}$, the maximum test voltage is reduced up to 20 % and with $f_{nom} \geq 60 \text{ Hz}$, the maximum test voltage is increased up to 16 %. The exciting current will not be corrected as the influence is very small.

Demagnetizing the CT core

Performing a CT Excitation measurement demagnetizes the CT core.

Demag. Demagnetization can also be done without recording an excitation curve by pressing the button **Demag**.

To make the context-dependent menu key **Demag**, visible put the focus onto the test card's tab.

Winding resistance

Use the test card **RWinding** to measure the resistance of a current transformer's secondary winding.

DANGER

Death or severe injury caused by high voltage or current

Injecting direct current into test objects with inductive characteristics will charge the winding of the test object.

- ▶ Follow instructions below.
- ▶ See section "DC output to test objects with a high inductance" on page Preface-4.

DANGER

Death or severe injury caused by high voltage or current

- ▶ Never open the measuring circuit while current flows.
- ▶ Make sure that no other secondary windings are open.
- ▶ After a measurement, wait until the *CPC 100* has discharged completely.
- ▶ Before disconnecting from the *CPC 100*, connect the device under test on both ends to protective earth.
- ▶ Short-circuit the winding under test before disconnecting the test leads.

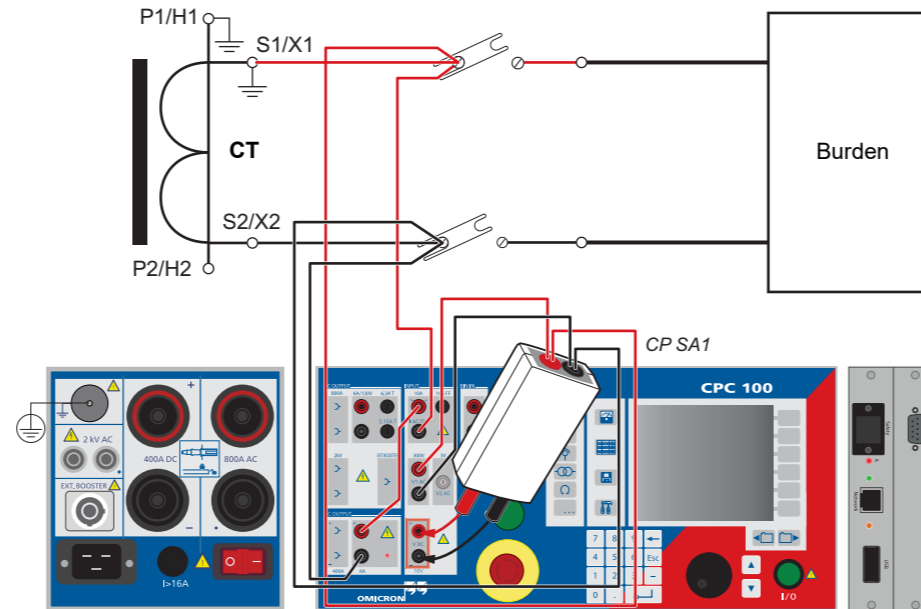

Select to stop test automatically when measurement is done.

Output range	Range: DC 6A	<input checked="" type="checkbox"/> Auto	Measurement range
Nominal test current	I test: 5.000 A	R min: 40.00 $\mu\Omega$	Maximum deviation between the measured values within the last 10 s of the measurement. The results are considered stable if Dev < 0.1 %.
Actual test current	I DC: 4.9690 A	R max: 2.0000 Ω	
Measured voltage at input V DC	V DC: 1.9920 V	Dev.: 0.06 %	Total elapsed time
Transformer's winding resistance	R meas.: 400.9 m Ω	Time: 43.000 s	
Enable/disable temperature compensation for the result	<input checked="" type="checkbox"/> Temperature compensation	T meas.: 25.0 $^{\circ}\text{C}$	T ref.: 75.0 $^{\circ}\text{C}$ Material: Cu R ref.: 478.0 m Ω Assessed: n/a
		T ref.: 75.0 $^{\circ}\text{C}$	
		Material: Cu	
		R ref.: 478.0 m Ω	

Buttons: Insert Card, Delete Card, Rename Card, Clear Results, Save As Default, Keep Result

Note: If n/a appears in the V DC or R meas box, the V DC input is overloaded.

Voltage Withstand test

Use the test card **VWithstand** to measure the voltage withstand capability of the secondary winding and secondary wiring. To do so, disconnect the burden. As shown in the following figure, connect one cable of the **2 kV** output to the transformer's secondary (1S1) winding connection and the other cable to earth and the transformer's primary connection (P1). Open the secondary ground connection and ground the burden for safety reasons.

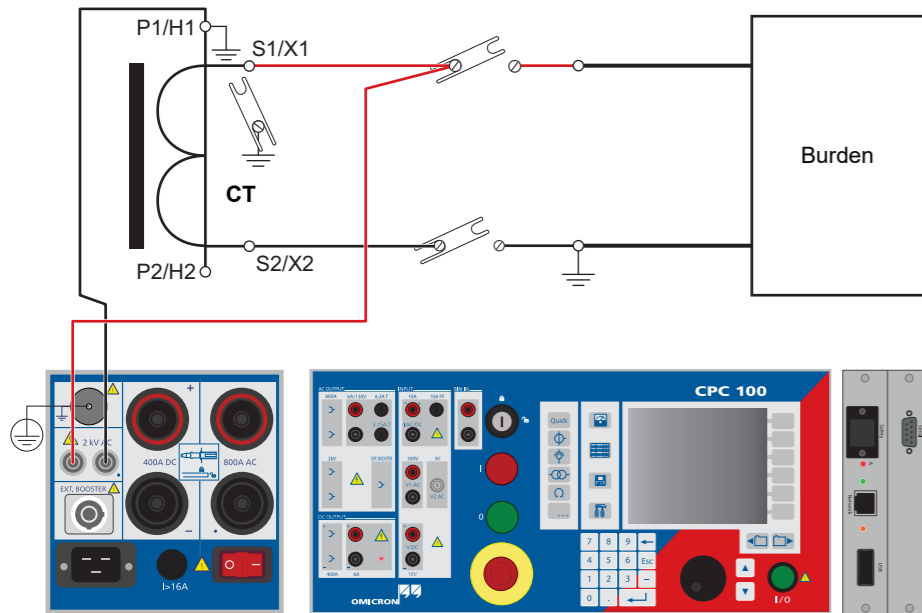

DANGER

Death or severe injury caused by high voltage or current

- ▶ Do not touch the terminal connected to the transformer's secondary connection "1S1", it carries life-hazardous voltage.

Terminates test when current threshold is reached

Nominal test voltage (2kV max.)

Output frequency

Terminates test when testing time has elapsed

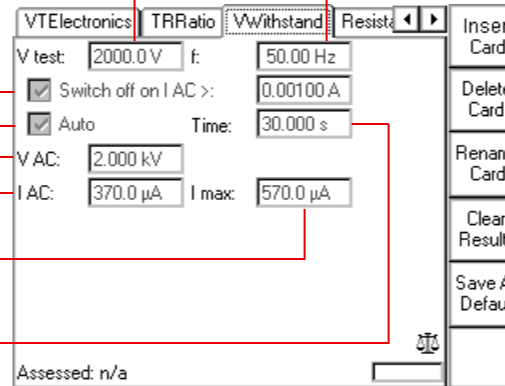

Actual test voltage

Actual test current

Highest measured current

Time span V test is applied to the output

During the test, the test voltage increases in a ramp characteristic from 0 V to **V test**. **V test** is then applied to the output for the specified time span. The measurements are continuously taken. Afterwards, **V test** decreases in a ramp characteristic.

Polarity Check

Use the **PoICheck** test card to check a series of test points for correct polarity.

To do so, the *CPC 100* injects a special polarity test signal at a certain location. This signal can either be a voltage or a current signal from the *CPC 100*, and has a signal characteristic similar to a saw-tooth signal with a different steepness for the rising and the falling slope.

The polarity check itself is then done with the *CPOL2*, a portable polarity checker.



If the *CPOL2* detects the same signal characteristic at a test point, it considers the polarity as OK, and lights up the green LED.



If the signal characteristic is inverted or distorted, the *CPOL2* considers the polarity not OK, and lights up the red LED.

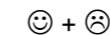

If the *CPOL2* detects a signal that is too low, both LEDs light up at the same time. Remedy: increase the signal magnitude.

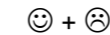

If the capacity of the *CPOL2*'s battery gets low, the LEDs start flashing. As long as the LEDs are flashing, the *CPOL2*'s battery provides sufficient power to continue working. However, the battery should be changed as soon as possible.

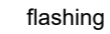

DANGER

Death or severe injury caused by high voltage or current



- ▶ Never operate the *CPOL2* with an open battery compartment. A life-hazardous voltage level may occur in the battery compartment if the *CPOL2*'s probe touches a test point with high-voltage potential!
- ▶ Handle with extreme caution: Do not touch the test point with your fingers.
- ▶ If you detect a wrong polarity in the current path, turn off the *CPC 100* first, and only then disconnect the terminals.

Polarity Check

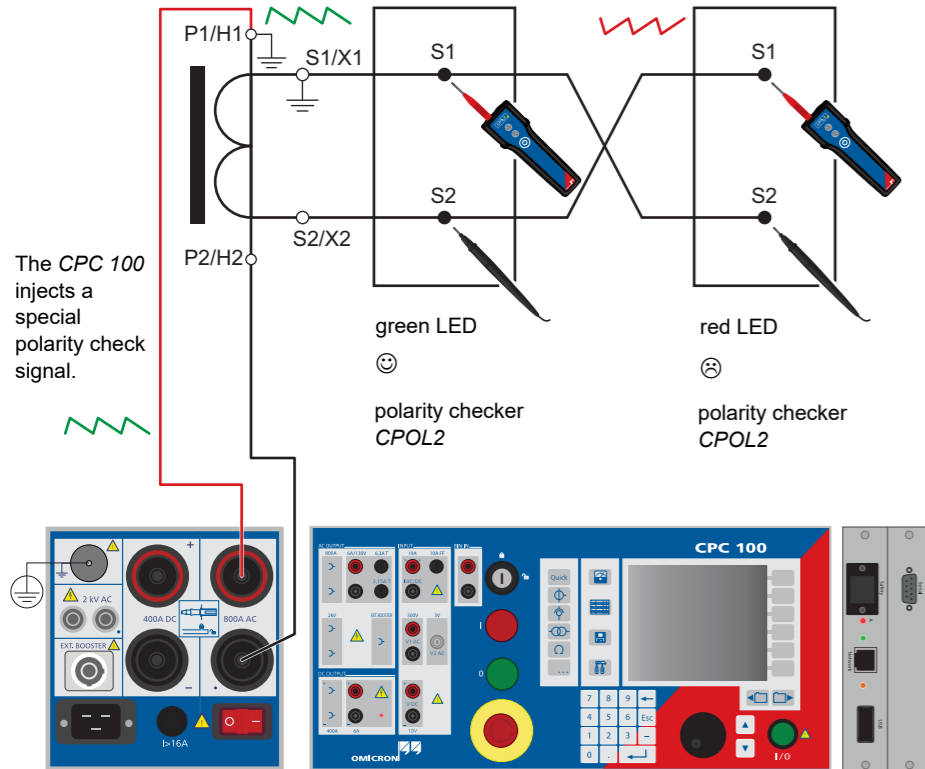

Select the option **Intermittent** to save power in the 800A AC output range and define a pulse duty cycle for the output signal:

T on: time span the signal is applied to the output

T off: time span the signal output is paused

A T on / T off ratio of 2.000 s / 9.000 s means the signal is applied for 2 seconds, then paused for 9 seconds. After that the cycle repeats.

Select output range

Amplitude

Enter results manually

Location	Assessment
Point 1	OK
Point 2	OK
Point 3	OK
Point 4	Failed

Use the **CTRatioV** test card to measure a current transformer's ratio. To do so, feed a voltage of up to 500 V from the **2kV AC** output to the transformer's secondary side.

CTRatioV (with voltage)

The preferred method for CT ratio measurement is current injection using the **CTRatio** test card. However, on some GIS CTs or bushing CTs on power transformers where the primary current path is not accessible, the method described in this section is the only solution.

To measure the CT ratio using the **CTRatioV** test card, connect the **2kV AC** output to the CT's secondary winding and the **V2 AC** input to the main conductors, e.g. on a power transformer to the transformer's bushings of different phases.

DANGER

Death or severe injury caused by high voltage or current

Feeding test voltage to a tap of a multi-ratio CT can cause life-threatening voltages on other taps with higher ratios.

- ▶ Do not touch tapped windings.
- ▶ Make sure that no other secondary windings are open.

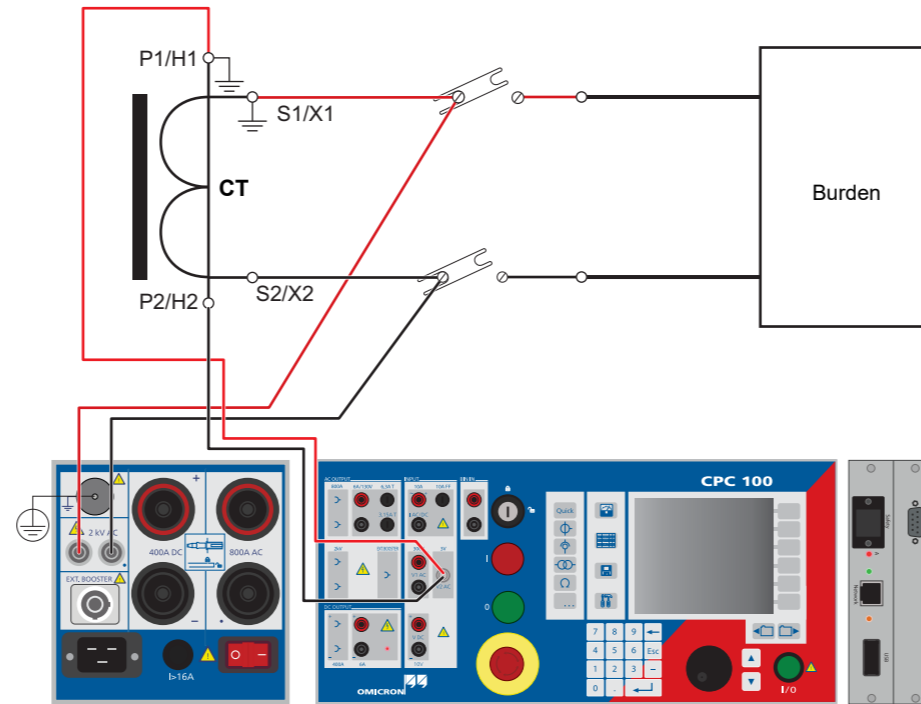

CTRatio (with voltage)

Secondary inception voltage	Nominal primary current	Nominal secondary current	
Output frequency	CTBurden 1	CTExcitation 1	CTRatioV 1
Measured secondary voltage	I prim.: 200.0 A	I sec.: 5.000 A	
	V test: 50.0 V	f: 50.00 Hz	<input checked="" type="checkbox"/> Auto
Primary voltage measured on V2 AC input	V sec.: 49.990 V	Iout: 46.79 mA	
	V prim.: 626.3 mV	-0.80°	<input type="checkbox"/> Manual input
	Ratio: 200.0:2.506	-49.889 %	
	Polarity: OK		
	Assessed:n/a		

Select to stop test automatically when measurement is done
 Select to enter primary voltage instead of measuring it
 Ratio error

$$\text{Ratio } I_{\text{sec}} / I_{\text{prim}} : I_{\text{sec act}} \times (I_{\text{prim nom}} / I_{\text{prim act}}) \text{ and deviation in } \% ((K_n \times I_{\text{sec}} - I_{\text{prim}}) / I_{\text{prim}}) \times 100 \%$$

Polarity:
 OK = phase I sec - phase I prim = -45° < 0° < +45°
 NOTOK = all other cases

Note: If the transformer's knee point voltage is approximated or exceeded, due to the transformer's saturation the measurement results are not correct anymore. If the knee point is extensively exceeded, the transformer can even be damaged. Therefore, the knee point voltage should be known or measured beforehand.

CTRogowski

Use the **CTRogowski** test card to measure a Rogowski coil's ratio by injecting current into the current-carrying conductor, and by measuring the induced voltage at the end of the Rogowski coil windings.

A Rogowski coil's induced voltage is proportional to the conductor current differentiated with respect to time. Therefore, in order to acquire a direct equivalent of the conductor's current, the induced voltage needs to be integrated. In general, a Rogowski coil's output signal is either lead via an integrating amplifier or fed into an electronic protection relay with integrator. The **CTRogowski** test card integrates the Rogowski coil's output signal at the **CPC 100's V2 AC** input.

Disconnect the Rogowski coil's output signal from the electronic protection relay, and plug it into the **CPC 100's V2 AC** input.

The **CTRogowski** test card measures the amplitude of the injected current **I prim** and the Rogowski coil's output voltage **V sec**, integrates this signal, and calculates the secondary current **I sec**, its phase angle as well as the actual ratio and the deviation.

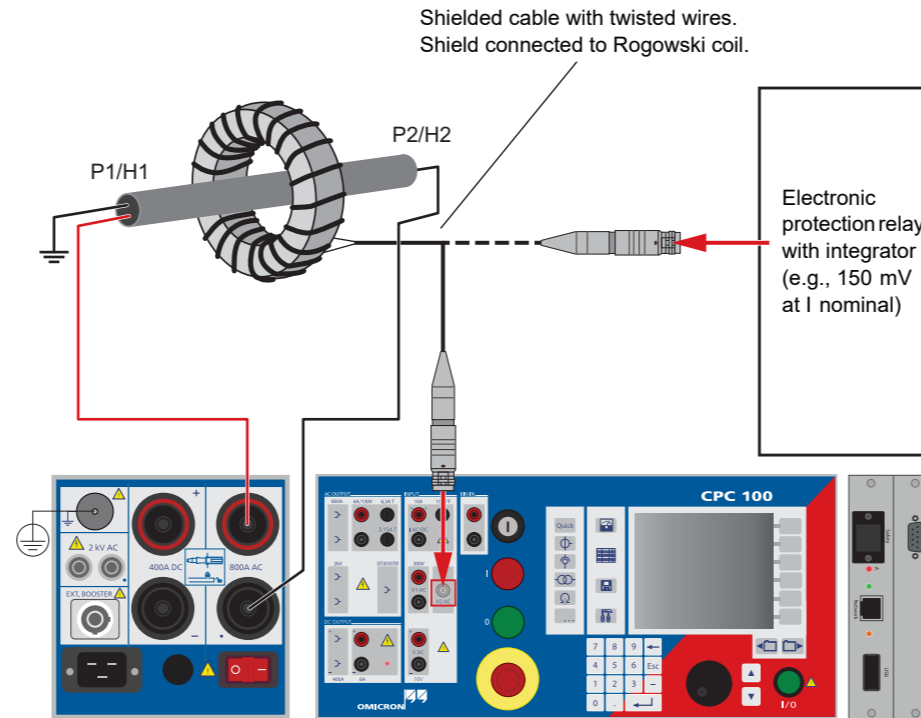

Nominal secondary voltage of Rogowski coil

Nominal primary current of Rogowski coil

Primary injection current

Actual output current

Secondary voltage

Calculated secondary current *)

Select check box for automatic test, clear for manual test

Nominal frequency of the Rogowski coil's secondary voltage

Frequency of injected current I test

Select to manually enter V sec instead of measuring it

Ratio: I prim / I sec and deviation of current ratio in %

Polarity:
 OK = phase I sec - phase I prim = -45° < 0° < +45°
 NOTOK = all other cases

Quick 1 C Rogowski 1

Range: AC 800A

I prim.: 240.0 A

I test: 240.0 A

I prim.: 239.87 A

V sec.: 149.9 mV

I sec.: 239.84 A

Ratio: 240.0:239.97

Polarity: OK

Assessed:n/a

Output range

V sec.: 150.0 mV

f nom.: 50.0 Hz

f: 50.00 Hz

Manual input

0.16°

-0.012 %

Auto

Insert Card

Delete Card

Rename Card

Clear Results

Save As Default

Settings

*) Note that the current **I sec** does not really exist in the system. It is a calculated current only.

CTLowPower (ratio)

Use the **CTLow Power** test card to measure the ratio of a low-power current transformer with a built-in burden and an output voltage that is directly proportional to the primary current.

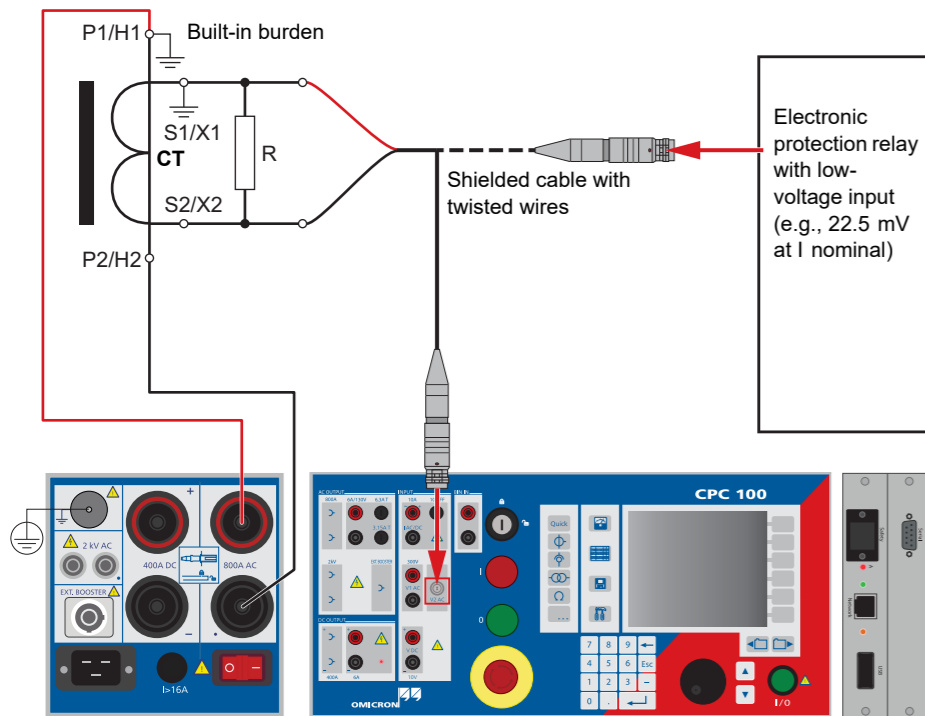

Nominal primary current	Nominal secondary voltage	Select to stop test automatically when measurement is done																																																						
Primary injection current	Output range																																																							
Actual current injected into CT's primary side	<table border="1"> <tr> <td colspan="2">CTLowPower 1</td> <td>VTRatio 1</td> <td>VTBurden 1</td> <td>VT</td> <td>Insert Card</td> </tr> <tr> <td>Range:</td> <td>AC 800A</td> <td><input checked="" type="checkbox"/> Auto</td> <td></td> <td></td> <td>Delete Card</td> </tr> <tr> <td>I prim.:</td> <td>200.0 A</td> <td>V sec.:</td> <td>22.5 mV</td> <td></td> <td>Rename Card</td> </tr> <tr> <td>I test:</td> <td>200.0 A</td> <td>f:</td> <td>50.00 Hz</td> <td></td> <td>Clear Results</td> </tr> <tr> <td>I prim.:</td> <td>199.99 A</td> <td><input type="checkbox"/> Manual input</td> <td></td> <td></td> <td>Save As Default</td> </tr> <tr> <td>V sec.:</td> <td>22.53 mV</td> <td>0.00 °</td> <td></td> <td></td> <td>Settings</td> </tr> <tr> <td>Ratio:</td> <td>200.0:22.53 A/mV</td> <td>0.138 %</td> <td></td> <td></td> <td></td> </tr> <tr> <td>Polarity:</td> <td>OK</td> <td></td> <td></td> <td></td> <td></td> </tr> <tr> <td>Assessed:</td> <td>n/a</td> <td></td> <td></td> <td></td> <td></td> </tr> </table>	CTLowPower 1		VTRatio 1	VTBurden 1	VT	Insert Card	Range:	AC 800A	<input checked="" type="checkbox"/> Auto			Delete Card	I prim.:	200.0 A	V sec.:	22.5 mV		Rename Card	I test:	200.0 A	f:	50.00 Hz		Clear Results	I prim.:	199.99 A	<input type="checkbox"/> Manual input			Save As Default	V sec.:	22.53 mV	0.00 °			Settings	Ratio:	200.0:22.53 A/mV	0.138 %				Polarity:	OK					Assessed:	n/a					Phase angle ϕ relative to Iprim
CTLowPower 1		VTRatio 1	VTBurden 1	VT	Insert Card																																																			
Range:	AC 800A	<input checked="" type="checkbox"/> Auto			Delete Card																																																			
I prim.:	200.0 A	V sec.:	22.5 mV		Rename Card																																																			
I test:	200.0 A	f:	50.00 Hz		Clear Results																																																			
I prim.:	199.99 A	<input type="checkbox"/> Manual input			Save As Default																																																			
V sec.:	22.53 mV	0.00 °			Settings																																																			
Ratio:	200.0:22.53 A/mV	0.138 %																																																						
Polarity:	OK																																																							
Assessed:	n/a																																																							
Measured secondary voltage		Select to enter secondary voltage instead of measuring it																																																						

Ratio Iprim. / Isec.:	Polarity:
$I_{sec\ act} \times (I_{prim\ nom} / I_{prim\ act})$	OK = phase I sec - phase I prim
and deviation in %	= -45° < 0° < +45°
$((K_n \times I_{sec} - I_{prim}) / I_{prim}) \times 100\ %$	NOTOK = all other cases

SV-Ratio

The **SV-Ratio** test card is mainly used to check the ratio between the output current or voltage and the input current or voltage of the selected merging unit channel according to the IEC 61850 standard. In addition, the **SV-Ratio** card is also used to determine the polarity of the signal, whereas the *CPC 100* serves as the signal source. The merging units generate the input voltages or currents.

The *CPC 100* test system performs closed-loop testing whereby a test signal is injected on the primary side of the current/voltage sensors. The Merging Unit (MU) converts the sensor output into an SV stream which is published to the substation network. The *CPC 100* then reads the data back from the network in order to perform a variety of different tests.

The *CPC 100* transforms the sampled points to the spectral function of the signal. This Fourier-transformed sampled values signal is filtered with a special Hann window to only retrieve the "signal" at the selected frequency. This allows frequency-selective measurements to be performed on SV streams and thereby the noise is suppressed.

The **SV-Ratio** test card can be accessed from **CT**, **VT** or **Others**.

The following tests can be performed:

- Ratio and polarity
- Automatic MU detection
- Frequency-selective current/voltage measurement
- Noise level measurement
- Magnitude response of the signal processing chain (15 to 400 Hz)

Block diagram of a typical measurement setup:

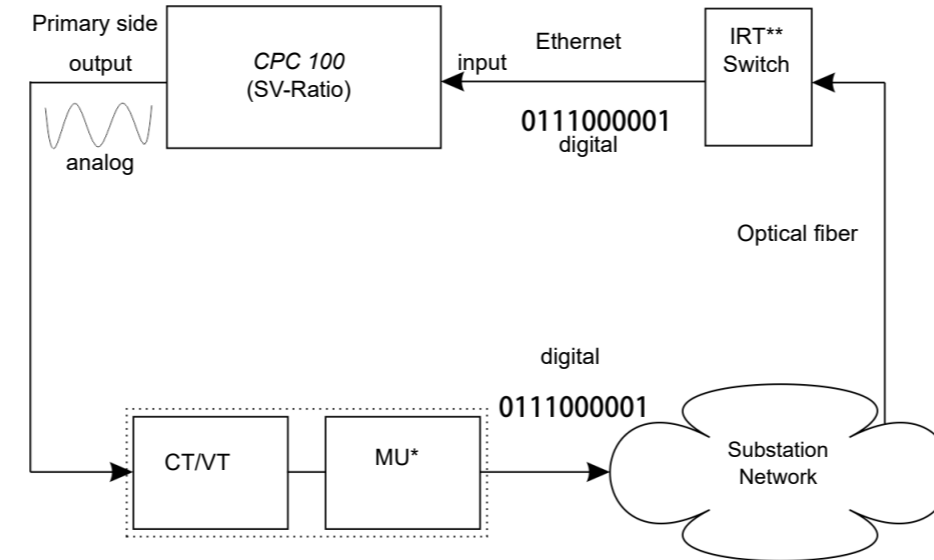

* If the MU has an Ethernet output, no IRT switch is required.

** IRT Switch: Industrial Real-Time Switch

Note: The **SV-Ratio** test card can be used both for current transformers and voltage transformers alike. Therefore, the description refers to currents and voltages.

Output range

Output frequency

Primary injection current or voltage

Nominal primary current or voltage

Refresh stream

Stream information

Selected stream

Channel selection

Select to choose channels automatically

Refer to the selected Range (I or V)

Deviations of actual ratio from nominal ratio in %

Channel name; refers to the selected Range (either I or V)

Output current or voltage

Primary values

Calculated ratio value from measured values

Identifies quality of the connection

Polarity status

Chn.	I out	I sv	:1	%	Pol.
Ia	n/a	1000.0	n/a	n/a	n/a

Voltage transformer

CPC 100 User Manual

VTRatio

Use the **VTRatio** test card to measure a voltage transformer's ratio with injection on the VT's primary side with up to 2 kV from **AC OUTPUT**.

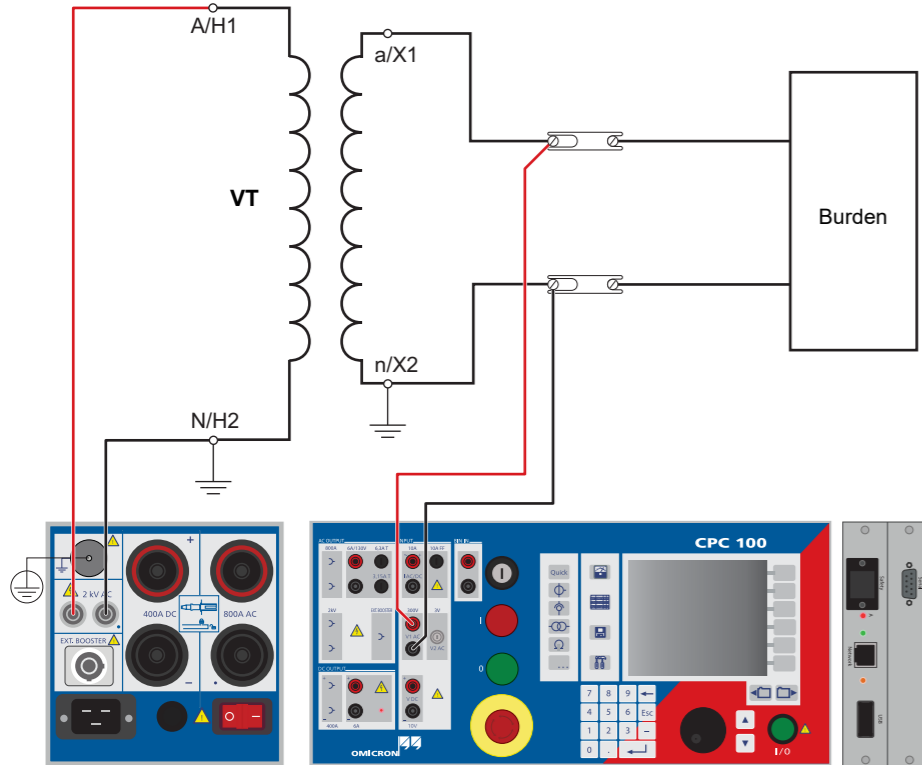

DANGER

Death or severe injury caused by high voltage or current

- ▶ Do not connect the *CPC 100* output to the secondary side of the VT. This will cause hazardous voltages on the primary side
- ▶ For VT ratio measurement, connect the *CPC 100* output to the primary side of the VT.

Correction factor for V prim: 1/n and n: Correction factors for V sec

Nominal primary voltage: 10000.0 V

Nominal secondary voltage: 100.0 V

Primary injection voltage: VTRatio 1

Output frequency: 50.00 Hz

Measured primary voltage: V prim: 2.000 kV

Secondary voltage measured at V1 AC, and its phase angle relative to the measured Vprim: V sec: 20.087 V, Ratio: 10000.0/3:100.43/3, Polarity: OK

Ratio and deviation in %: 0.433 %

Polarity: OK = phase I sec - phase I prim / = - 45 ° < 0 ° < + 45 °
NOTOK = all other cases

Select to stop test automatically when measurement is done

Select to enter secondary voltage instead of measuring it

VTBurden

Use the **VTBurden** test card to measure a voltage transformer's secondary burden with voltage injection on the VT's secondary side with up to 130 V from **AC OUTPUT**.

To do so, open the circuit as shown in the figure below, and inject the AC voltage from the *CPC 100*'s **130V AC** output into the burden. Input **I AC** measures the current that flows into the burden, and input **V1 AC** the voltage at the burden.

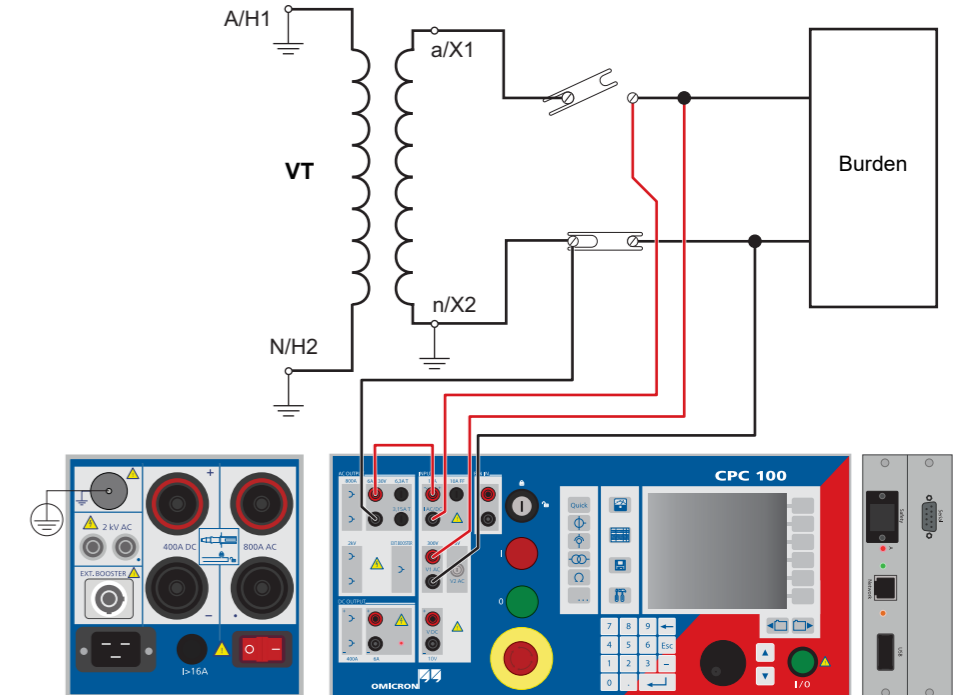

VTBurden

DANGER

Death or severe injury caused by high voltage or current

- ▶ Make sure that A/H1 is connected to ground.
- ▶ Disconnect the burden from the VT's secondary side before starting the measurement.

Output frequency

Correction factor for Vsec

Nominal secondary voltage

Select to stop test automatically when measurement is done

Secondary injection voltage from 130V AC output

TRRatio 1 TRRatio 2 **VTBurden 1** TRTapCh

V sec.: 100.00 V

1/√3 1/3

f: 60.00 Hz Auto

V test: 100.00 V

V sec.: n/a Current clamp I sec.

I sec.: n/a n/a Manual input

Burden: n/a cos φ: n/a

Use current clamp rather than input I AC*)

Select to enter secondary current instead of measuring it

Assessed: n/a

Cosinus of phase angle φ

Burden in VA: $V_{sec\ nom} \times (I_{sec\ act} \times V_{sec\ nom} / V_{sec\ act})$

Back to Top

*) Due to cross-talk between the measuring inputs V1 AC and V2 AC, we suggest not to connect a current clamp to the input V2 AC. Therefore, use a current clamp with current output.

Voltage Withstand test

This test is identical to the voltage withstand test described on page Current Transformer-5.

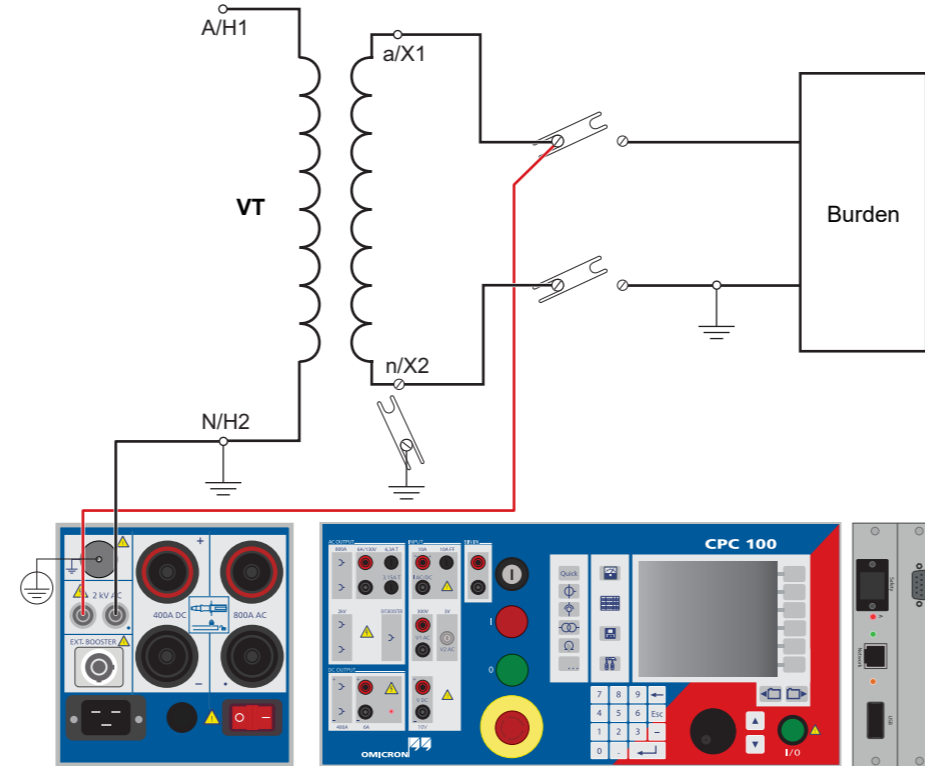

Polarity Check

This test is identical to the polarity check described on page Current Transformer-5.

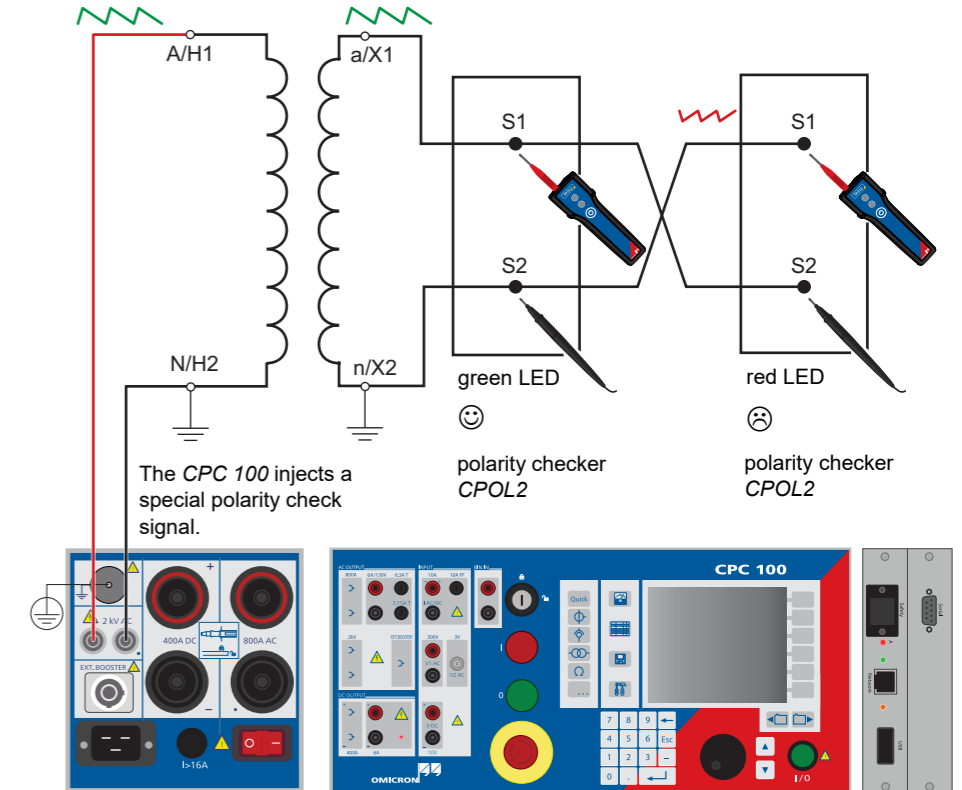

VTElectronics

Use the **VTElectronics** test card to test the ratio of non-conventional electronic voltage transformers with a very low-level secondary voltage.

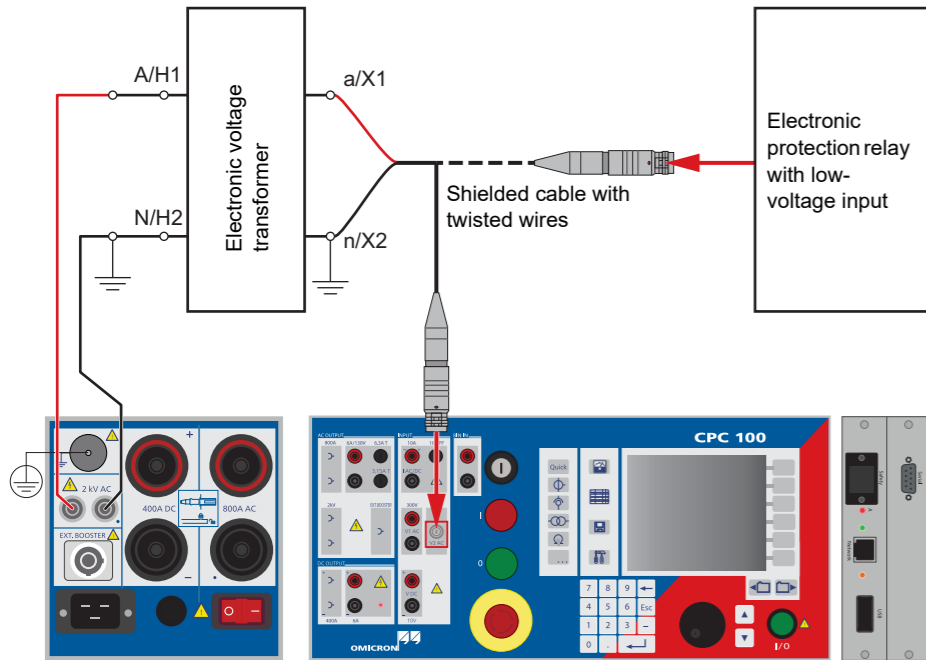

Correction factor for V prim	Nominal primary voltage	1/√3 and 1/3: Correction factors for V sec	
Primary injection voltage		Nominal secondary voltage	
Output frequency	VTBurden 1	VTElectronics 1	VWithstand 1
Measured primary voltage	V prim.: 10000.0 V	V sec.: 1.0000 V	
Secondary voltage measured at V1 AC, and its phase angle relative to the measured Vprim	<input checked="" type="checkbox"/> 1/√3	<input checked="" type="checkbox"/> 1/3	<input type="checkbox"/> 1/3
	V test: 2000.0 V		
	f: 50.00 Hz	<input checked="" type="checkbox"/> Auto	
	V prim.: 2.000 kV		
	V sec.: 200.4 mV	0.10 *	<input type="checkbox"/> Manual input
	Ratio: 10000.0/√3:1.002/√3	0.205 %	
	Polarity: OK		
	Assessed: n/a		
	Ratio and deviation in %		
	Polarity:		
	OK = phase I sec - phase I prim		
	= - 45 ° < 0 ° < + 45 °		
	NOTOK = all other cases		

Select to stop test automatically when measurement is done

Select to enter secondary voltage instead of measuring it

Transformer

CPC 100 User Manual

TRRatio (per tap)

Use the **TRRatio** test card to measure a power transformer's ratio by injecting AC voltage with up to 2 kV from **AC OUTPUT** into the transformer's primary side (refer to the following figure).

Setup for testing a power transformer ratio: YNyn0 transformer, primary and secondary side star connection.

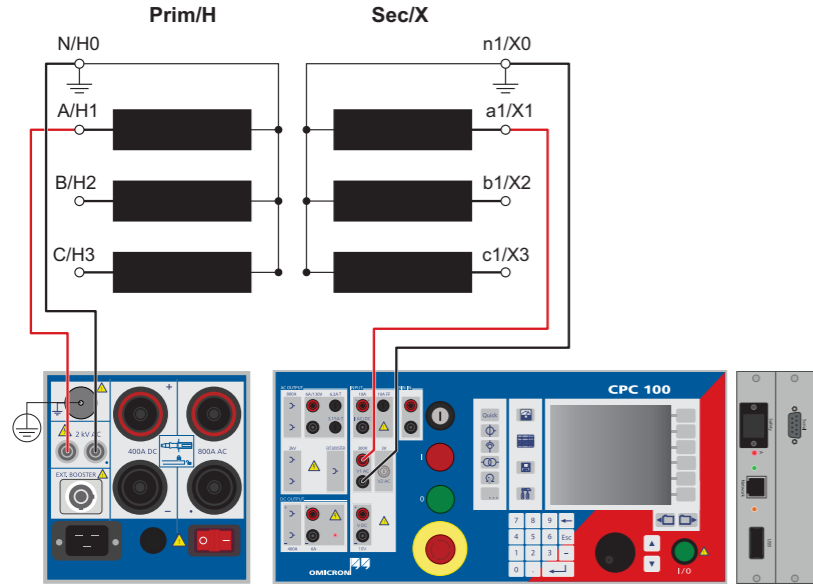

DANGER

Death or severe injury caused by high voltage or current

- ▶ Do not connect the *CPC 100* output to the secondary side of the transformer. This will cause hazardous voltages on the primary side

Output frequency

Nominal primary injection voltage

Primary current from 2kV AC output; changes depending on the line selected in table below

Nominal ratio, calculated from $V_{prim\ nom} / V_{sec\ nom}$

Vector group; selection depending on the settings

Actual voltage injected from AC OUTPUT into the transformer's high-voltage side

Operation mode

Transformer tap identifier and tap number for the measurements in the respective line of the table

V sec Actual voltage measured at V1 AC

° Phase angle of the primary current relative to Vprim nominal.

:1 Calculated ratio value from the measured values V_{prim} / V_{sec}

% Deviation of the actual ratio from the nominal ratio

TRRatio 1

Ratio: n/a

V test: 2000.0 V

f: 50.00 Hz

Auto-tap Manual wiring

I prim.:

Tap	V prim	V sec	°	:1	%
007	1999.5	4.4500	0.04	449.34	-1.15
008	1999.5	4.4499	0.04	449.35	-0.15
009	1999.5	4.4499	0.04	449.34	0.85
010	1999.6	4.4499	0.04	449.35	9.84

Assessed: n/a

Settings page



Pressing the **Settings** menu key opens the Settings page. The Settings page of the **TRRatio** test card has another functionality as on other test cards.

Note: The Settings page opens automatically if the **Auto-tap** operation mode is activated.

The Settings page allows adding the transformer's ratio per tap as follows. After pressing the **Add Tap** menu key first enter the Tap Number, V prim and V sec. Add the next tap by pressing the **Add Tap** menu key repeatedly adds more taps with a step calculated from the values of the preceeding taps. The tap entries apply equally to all phases. After adding all taps, press the **Main Page** menu key to transfer the data to the main page.

Use the **Automatic Tap Fill** function to automatically fill in the nominal ratio table of the **TRRatio** test card for symmetric tap changers.

Performing a TRRatio test (per tap)



While passing through the power transformer's tap changer positions, press **Keep Result** for each single position.

Note: This procedure is only required for manual wiring. Otherwise, the test runs fully automatically.

Settings page

Time needed to switch from one tap to the next

Measurement starts at the lowest or highest position

Select for the fully automatic and extended manual mode

Tap	V prim	V sec
001	127598.0	10750.0
002	126341.0	10750.0
003	125084.0	10750.0
004	123827.0	10750.0
005	122570.0	10750.0
006	121313.0	10750.0
007	120056.0	10750.0

Automatic Tap Fill

The **Settings** page of the **TRRatio** test card offers an offline **Auto-tap** fill function. It automatically fills in the nominal ratio table of the **TRRatio** test card for symmetric tap changers.

Auto fill settings

Auto-tap

Tap time: []

Total number of taps: [13]

Number of middle positions: [3]

Nominal ratio on middle positions: [110000.0 V] : [10000.0 V]

Deviation in between taps: [7.0 %]

HV tap changer

OK Cancel

Min Max

Number of taps with the specified nominal ratio in the middle of the symmetrical tap scheme

Voltage difference between positions

Activate if tap changer is on high-voltage side

The total number of taps minus the middle position(s) defines the number of taps above and below the middle position(s). To determine the voltage for each tap position, the nominal ratio of the middle position(s) and the deviation percentage are needed and the **HV tap changer** check box needs to be activated if applicable.

TRRatio (per tap)

The following table shows the **V prim** and **V sec** settings on the **TRRatio** test card for different transformer's winding connections.

Note: The table is valid for manual wiring and in connection with the *CP SB1*.

In the Transformer high-voltage side column, + means that the terminals in the *CP SB1* are short circuited.

IEC 60076 vector group	Winding connection		Measurement	Transformer high-voltage side	Transformer low-voltage side	Measured turn ratio
	HV / H	LV / X				
Dd0			A	U-V / H1-H2	u-v / X1-X2	1
			B	V-W / H2-H3	v-w / X2-X3	
			C	W-U / H3-H1	w-u / X3-X1	
Yy0			A	U-V / H1-H2	u-v / X1-X2	1
			B	V-W / H2-H3	v-w / X2-X3	
			C	W-U / H3-H1	w-u / X3-X1	
Dz0			A	U-V / H1-H2	u-v / X1-X2	1
			B	V-W / H2-H3	v-w / X2-X3	
			C	W-U / H3-H1	w-u / X3-X1	
Dy5			A	U-(V+W) / H1-(H2+H3)	w-u / X3-X1	$\sqrt{3}/2$
			B	V-(U+W) / H2-(H1+H3)	u-v / X1-X2	
			C	W-(U+V) / H3-(H1+H2)	v-w / X2-X3	

IEC 60076 vector group	Winding connection		Measurement	Transformer high-voltage side	Transformer low-voltage side	Measured turn ratio
	HV / H	LV / X				
Yd5			A	U-(V+W) / H1-(H2+H3)	w-u / X3-X1	$\sqrt{3}/2$
			B	V-(U+W) / H2-(H1+H3)	u-v / X1-X2	
			C	W-(U+V) / H3-(H1+H2)	v-w / X2-X3	
Yz5			A	U-(V+W) / H1-(H2+H3)	w-u / X3-X1	$\sqrt{3}/2$
			B	V-(U+W) / H2-(H1+H3)	u-v / X1-X2	
			C	W-(U+V) / H3-(H1+H2)	v-w / X2-X3	
Dd6			A	U-V / H1-H2	v-u / X2-X1	1
			B	V-W / H2-H3	w-v / X3-X2	
			C	W-U / H3-H1	u-w / X1-X3	
Yy6			A	U-V / H1-H2	v-u / X2-X1	1
			B	V-W / H2-H3	w-v / X3-X2	
			C	W-U / H3-H1	u-w / X1-X3	
Dz6			A	U-V / H1-H2	v-u / X2-X1	1
			B	V-W / H2-H3	w-v / X3-X2	
			C	W-U / H3-H1	u-w / X1-X3	

IEC 60076 vector group	Winding connection		Measurement	Transformer high-voltage side	Transformer low-voltage side	Measured turn ratio
	HV / H	LV / X				
Dy11			A	U-(V+W) / H1-(H2+H3)	u-w / X1-X3	$1*\sqrt{3}/2$
			B	V-(U+W) / H2-(H1+H3)	v-u / X2-X1	
			C	W-(U+V) / H3-(H1+H2)	w-v / X3-X2	
Yd11			A	U-(V+W) / H1-(H2+H3)	u-w / X1-X3	$1*\sqrt{3}/2$
			B	V-(U+W) / H2-(H1+H3)	v-u / X2-X1	
			C	W-(U+V) / H3-(H1+H2)	w-v / X3-X2	
Yz11			A	U-(V+W) / H1-(H2+H3)	u-w / X1-X3	$1*\sqrt{3}/2$
			B	V-(U+W) / H2-(H1+H3)	v-u / X2-X1	
			C	W-(U+V) / H3-(H1+H2)	w-v / X3-X2	

TRRatio according to IEC 61378-1

The IEC 61378-1 is a standard for testing transformers with unconventional vector groups. Activate the **IEC 61378-1** check box to perform a measurement according to this standard. The test is vector-group independent.

Note: The **IEC 61378-1** check box is only available if the **CP SB1** switch box is connected.

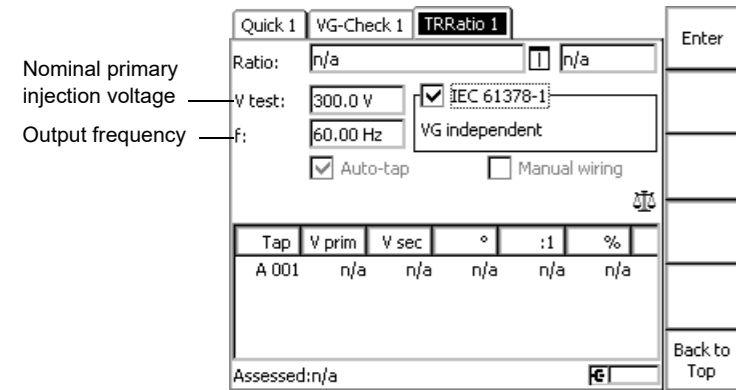

With the **IEC 61378-1** check box activated, the **CPC 100** carries out two standard-compliant measurements for each winding and calculates the transformer's turns ratio and phase shift. The measurement table displays the same values as for the standard **TRRatio** measurement. The magnetization current and phase angle will not be available in this mode.

Note: The **IEC 61378-1** test takes longer than a standard ratio measurement.

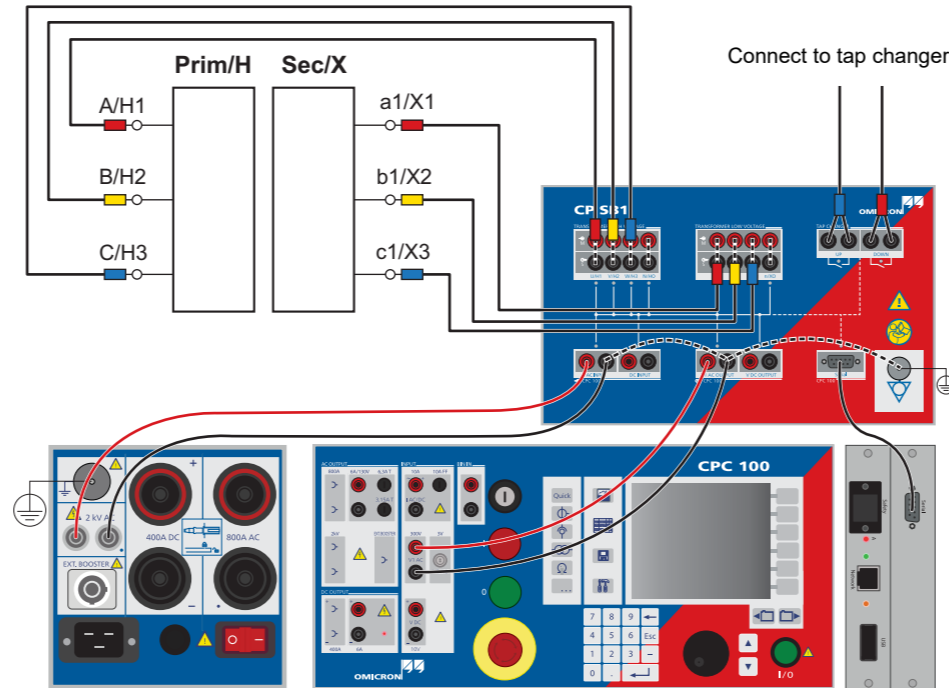

Vector Group Check

Use the **Vector Group Check** to automatically determine the transformer's vector group.

Note: The **Vector Group Check** test requires a **CP SB1** transformer switch box.

► Before starting the **Vector Group Check**, use the **Demag** test card with the **Wiring** set to **Yd5** or **Dy5** (see page 10 in this chapter) to ensure reliable results.

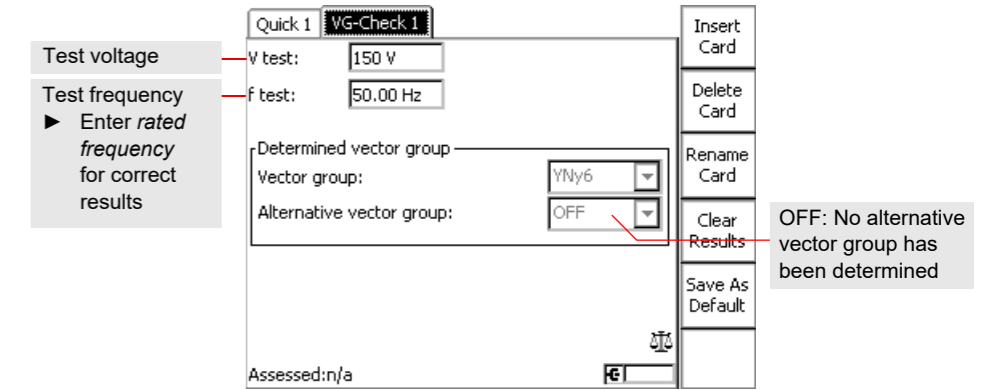

The **CPC 100** energizes the transformer's primary windings and measures the voltages on the secondary terminal. The optimized algorithm reduces the number of measurements. The vector group is determined according to the voltage distributions. In cases where the measurement results apply equally to two vector groups, an alternative group is provided.

DANGER
Death or severe injury caused by high voltage or current
 During the **Vector Group Check**, the **CPC 100** continuously puts out the set test voltage.
 ► Do not touch the **CPC 100**'s outputs and do not touch or unplug any cables.

Vector Group Check

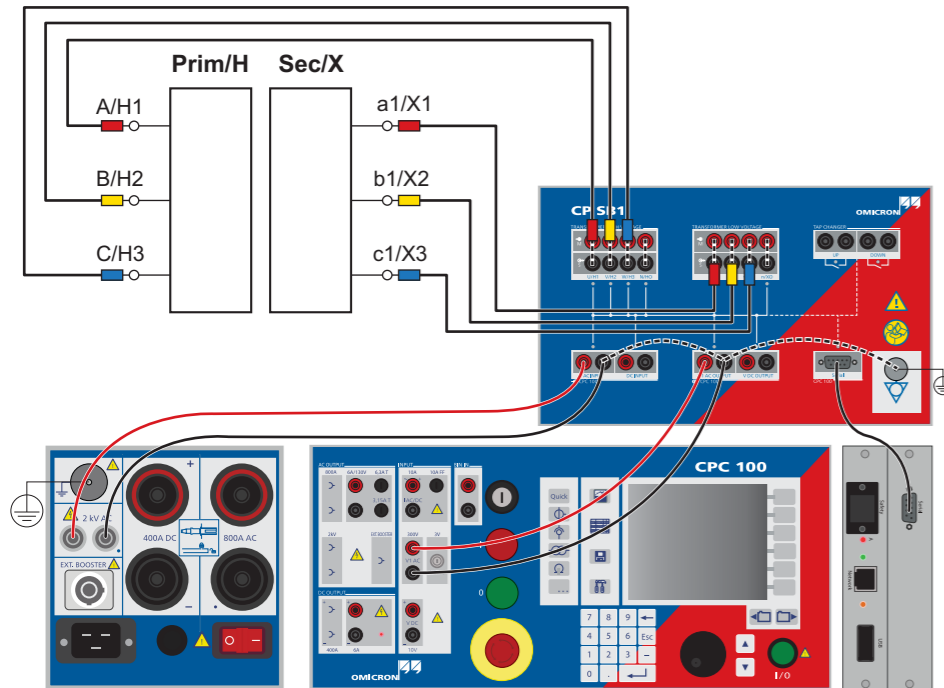

Winding Resistance

Use the **RWinding** test card to measure the resistance of a power transformer's winding as described on page Current Transformer-4. Alternatively, inject the current directly from the **400A DC** output as shown below.

DANGER

Death or severe injury caused by high voltage or current



Injecting direct current into test objects with inductive characteristics will charge the winding of the test object.

- ▶ Follow instructions below.
- ▶ See section "DC output to test objects with a high inductance" on page Preface-4.

DANGER

Death or severe injury caused by high voltage or current



- ▶ Never open the measuring circuit while current flows.
- ▶ After a measurement, wait until the test device has discharged completely.
- ▶ Ground all poles of the test object before touching the test setup.
- ▶ Short-circuit the terminals before disconnecting the test leads.
- ▶ Disconnect cables not used for testing both from the test object and the test device.

WARNING

Death or severe injury caused by high voltage or current possible



It is recommended to perform all winding resistance measurements with the **CP SA1** connected to the **CPC 100 V DC** input sockets to protect yourself and the **CPC 100** from high-voltage hazards.

- ▶ The **CP SA1** must be used for measurements using the **400A DC** output.

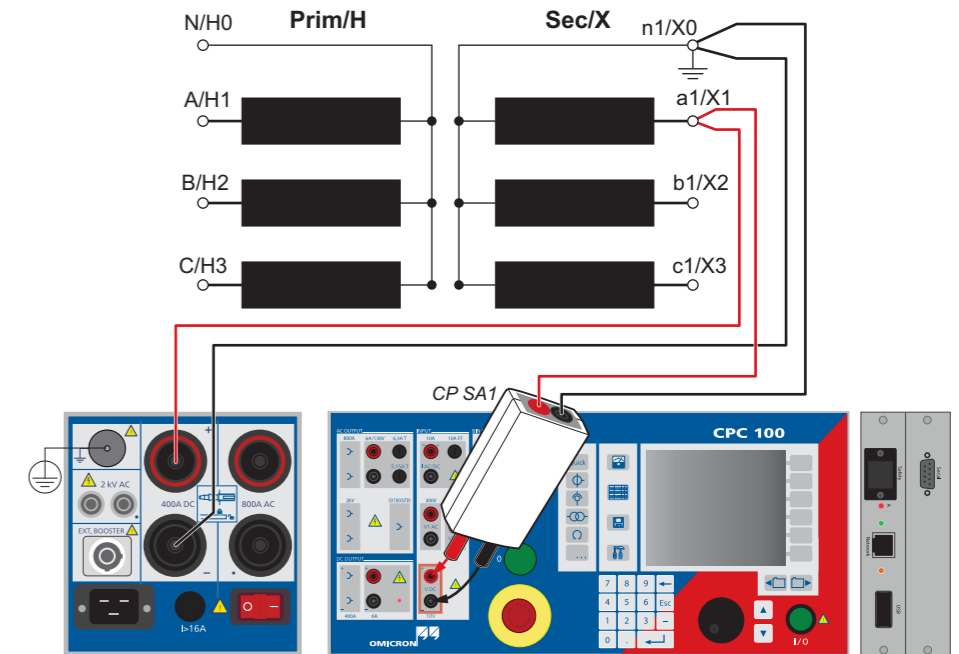

NOTICE

The **CP SA1** discharge box also protects the **CPC 100** from damages caused by high voltage.

Tap Changer Cleaner Sequence

The **Tap Changer Cleaner Sequence** is used to sweep all taps before performing a **Winding Resistance** measurement to ensure that the taps are clean.

Note: The **Tap Changer Cleaner Sequence** can only be activated if the *CP SB1* transformer switch box is connected and **Auto-tap** is selected.

The currently swept tap and the remaining time are displayed during the sequence.

Note: You can only interrupt the **Tap Changer Cleaner Sequence** by pressing the Emergency Stop button.

TRTapCheck (for OLTC)

Use the **TRTapCheck** test card to measure the winding resistance of the individual taps of a power transformer's tap changer, and to check whether the on-load tap changer (OLTC) switches without interruption.

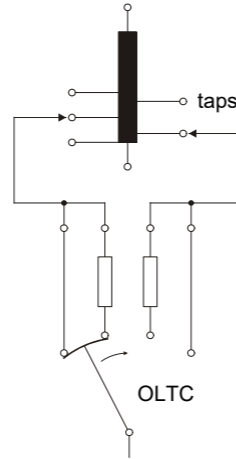

The *CPC 100* injects a constant current from the **6A DC** output into the power transformer and the current is led via the **I AC / DC** input for measurement. Alternatively, the current injected from the **400A DC** output is measured internally. From this current value and the voltage measured by the **V DC** input, the winding resistance is calculated.

In the moment the tap is changed, the **I AC / DC** measuring input detects the sudden, very short drop of the current flow. A properly working tap change differs from a malfunctioning one, e.g., an interruption during the change, by the magnitude of the ripple and slope values. An interruption will result in much higher ripple and slope values than a properly functioning tap change.

The ripple and slope values are indicated at the **TRTapCheck** test card's measurement table.

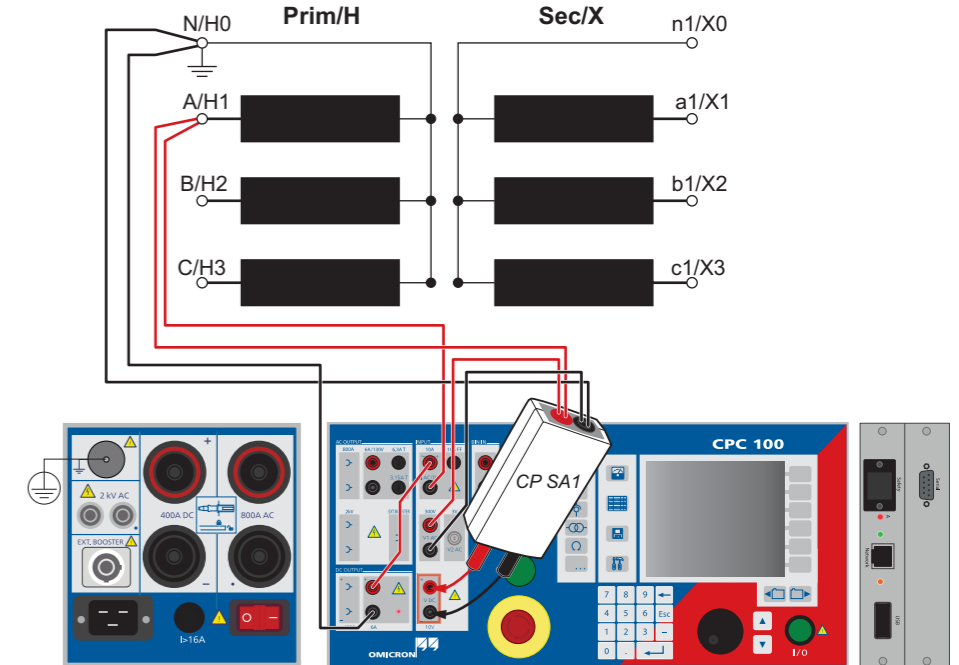

TRTapCheck (for OLTC)

The screenshot shows the TRTapCheck menu with the following callouts:

- Nominal test current:** Points to the Range field (DC 6A).
- Actual test current:** Points to the I test field (1.000 A).
- Measured voltage at V DC input:** Points to the V DC field (0.0000 V).
- Transformer tap identifier and tap number:** Points to the Tap field (A 001).
- Output range:** Points to the Range field.
- Winding connection:** Points to the Wiring field (YN).
- Reference temperature:** Points to the T field (75.0 °C / 25.0 °C).
- Actual specimen temperature:** Points to the T field.
- Automated tap operation:** Points to the Auto-tap checkbox.
- Tolerance of the deviation in %:** Points to the Tolerance field (0.5 %).
- Settling time:** Points to the Δ t field (10.0 s).
- Buttons:** Insert Card, Delete Card, Rename Card, Clear Results, Save As Default, Settings.

Rmeas: Actual resistance
 Dev.: Deviation in % between the maximum and the minimum measured values evaluated with the settling time.
 R ref.: Temperature-corrected resistance value
 Ripple: Samples and holds the biggest measured current ripple that occurred in the measuring cycle. It is indicated in % with reference to I DC.
 Slope: Samples and holds the biggest measured steepness of the falling edge of the actual test current.

Tap Changer Test and Measuring the Winding Resistance

When testing a tap changer, we recommend the following:

- ▶ Inject the same current value for each phase.
- ▶ To perform tests of each phase, start with the lowest tap through to the highest and continue backwards down to the lowest tap again. Taps may show quite different results depending on the direction of the tap movement and defects can behave differently. An interruption caused by a defective tap changer results in comparatively high measured values for ripple and slope.

Example: Results of a tap changer and winding resistance test

Tap	R meas.	Dev.	R ref.	Ripple	Slope
	Ω	%	Ω	%	A/s
A 001	10.042	0.15	11.973	n/a	n/a
A 002	10.035	0.12	11.965	63.970-160.1m	
A 003	10.025	0.22	11.952	64.360-167.9m	
A 004	9.9801	0.49	11.899	64.050-161.6m	
001	764m	0.05	913.0m	85.00	-50.50m
002	764m	0.05	913.0m	0.00	-15.57m
003	810m	10.7	974.0m	0.50	-31.44m
004	768m	0.05	917.7m	0.00	-13.04m
005	815m	9.70	974.0m	0.60	-30.27m
006	772m	0.04	922.0m	0.00	-12.35m
007	916m	9.74	1.01	20.00	-450.85m

For the tap changer test, the last two columns of the table are relevant.

High ripple because inductance is charged

Values okay because always in the same range

Tap defective: significantly higher values for ripple and slope. Compared to the properly functioning tap change of line 5, for the defective tap in line 7 the ripple is about 30 times and the slope about 15 times higher.

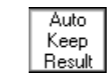

After pressing the **Auto Keep Result** menu key, the CPC 100 waits until stable results with a deviation less than the defined tolerance (in %) within the defined settling time (Δt) are achieved. After then, a new result line is added and the next measurement starts.

Note: If the CPC 100 is in **Auto Keep Result** status, the user can end the process by either pressing **Keep Result** or by changing to the Tolerance setting and changing the value. The context-dependent menu key **Set Current Deviation** resumes the value of the current deviation in the **Tolerance** field.

Performing a Tap Changer Test

DANGER



Death or severe injury caused by high voltage or current

Injecting direct current into test objects with inductive characteristics will charge the winding of the test object.

- ▶ Follow instructions below.
- ▶ See section "DC output to test objects with a high inductance" on page Preface-4.

DANGER



Death or severe injury caused by high voltage or current

- ▶ Never open the measuring circuit while current flows.
- ▶ After a measurement, wait until the test device has discharged completely.
- ▶ Ground all poles of the test object before touching the test setup.
- ▶ Short-circuit the terminals before disconnecting the test leads.
- ▶ Disconnect cables not used for testing both from the test object and the test device.



1. Press the I/O (test start/stop) push-button to start the test.
2. Press **Keep Result** to save the resistance value of this tap or press **Auto Keep Result**. In this case, the CPC 100 waits until stable results within the set **Tolerance** and Δt are achieved. After then, a new result line is added showing the number of the next measured tap.
3. Move to the next position on the tap changer.
4. Repeat steps 2 and 3 for all taps you want to measure.
5. Press the I/O (test start/stop) push-button to stop the test and wait until the transformer windings are discharged.



Dynamic OLTC-Scan (DRM)

Use the **Dynamic OLTC-Scan** test card to visualize the on-load tap changer's transient switching behavior and assess its condition.

Note: The CPC 100 **Dynamic OLTC-Scan** requires a CP SB1 transformer switch box.

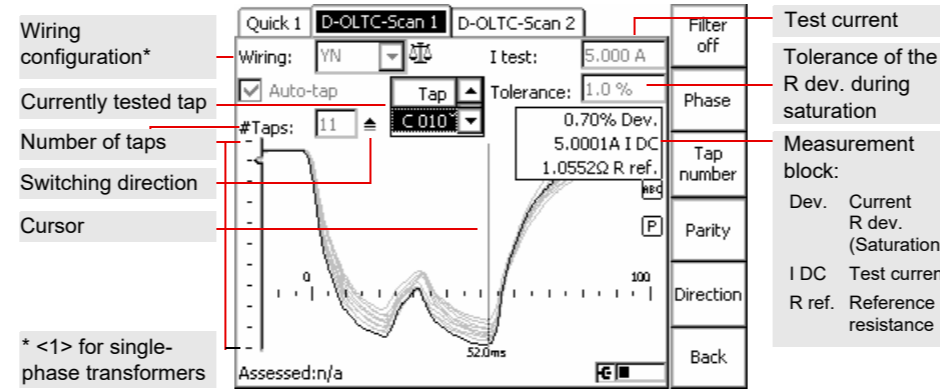

Status icons:

- Marks the detection phase during which the tap changer has to be actuated. This is either done automatically or manually.
- Time-out:** No switching operation has been detected during the **Tap time**. Only applicable when **Auto-tap** is activated.
- Data corruption:** A disturbance has been detected. This result is invalid. Delete the corrupted data row and the subsequent rows and restart the test from the last valid result.

Filter settings:

- Phase** Only display results from currently selected phase.
- Tap number** Only display results with same tap number.
- Parity** Only display results from taps with even/odd numbers.
- Direction** Only display results from one direction of OLTC movement.

- ▶ Press **View** and use the corresponding context-dependent menu keys to switch from the **Graph** view (default) to the **Chart** view (bar charts) or the **Table** view.
- ▶ Press **Meas. block** to hide/unhide the measurement block.
- ▶ Press **Mark** to place a ★ for later reference.
- ▶ Press **Set Current Deviation** to enter the value of the current R dev. into the **Tolerance** field.

Properties on the Settings page:

- Auto-tap** Activate for fully automatic mode
- Test mode**
 - **Basic:** standard test without dynamic LV shorting (current over time)
 - **OMICRON: Basic** mode expanded by dynamic shorting of the transformer's LV side for increased sensitivity
- Noise suppression** Select to activate an interference filter.
- Tap time** Time required for switching between two taps
- No. of sweeps** Used for the **Tap Changer Cleaner Sequence**
- Material** Winding material
- T meas.** Measurement temperature
- T ref.** Reference temperature
- T rec.** Recording time

Dynamic OLTC-Scan (DRM)

DANGER



Death or severe injury caused by high voltage or current

Injecting direct current into test objects with inductive characteristics will charge the winding of the test object.

- ▶ Follow instructions below.
- ▶ See section "DC output to test objects with a high inductance" on page Preface-4.

DANGER



Death or severe injury caused by high voltage or current

- ▶ Never open the measuring circuit while current flows.
- ▶ After a measurement, wait until the test device has discharged completely.
- ▶ Ground all poles of the test object before touching the test setup.
- ▶ Short-circuit the terminals before disconnecting the test leads.
- ▶ Disconnect cables not used for testing both from the test object and the test device.

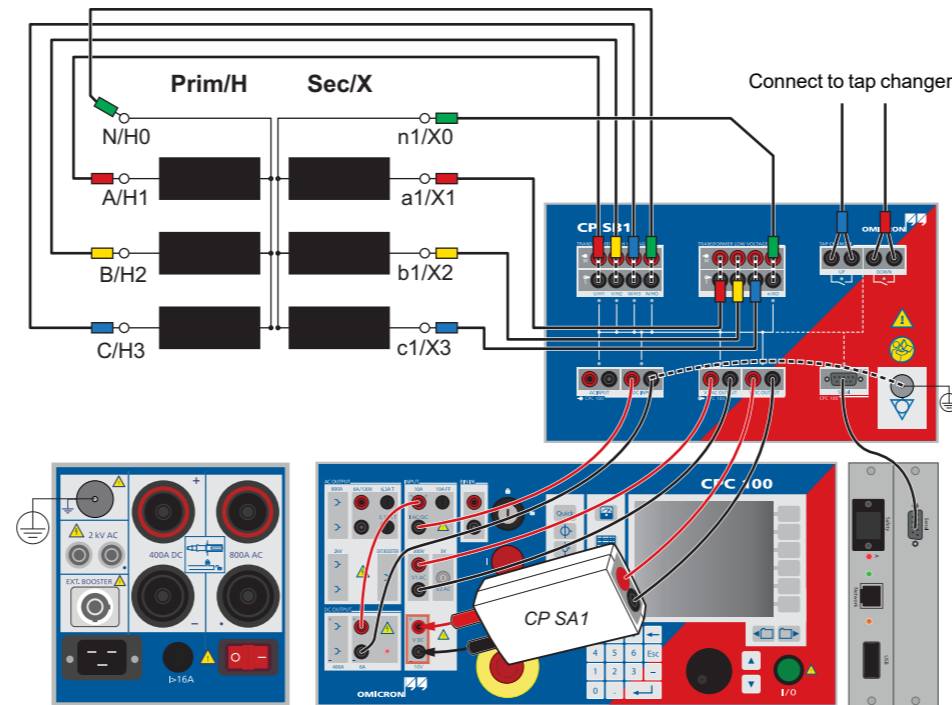

Voltage Withstand Test

This test is identical to the voltage withstand test described on page Current Transformer-5.

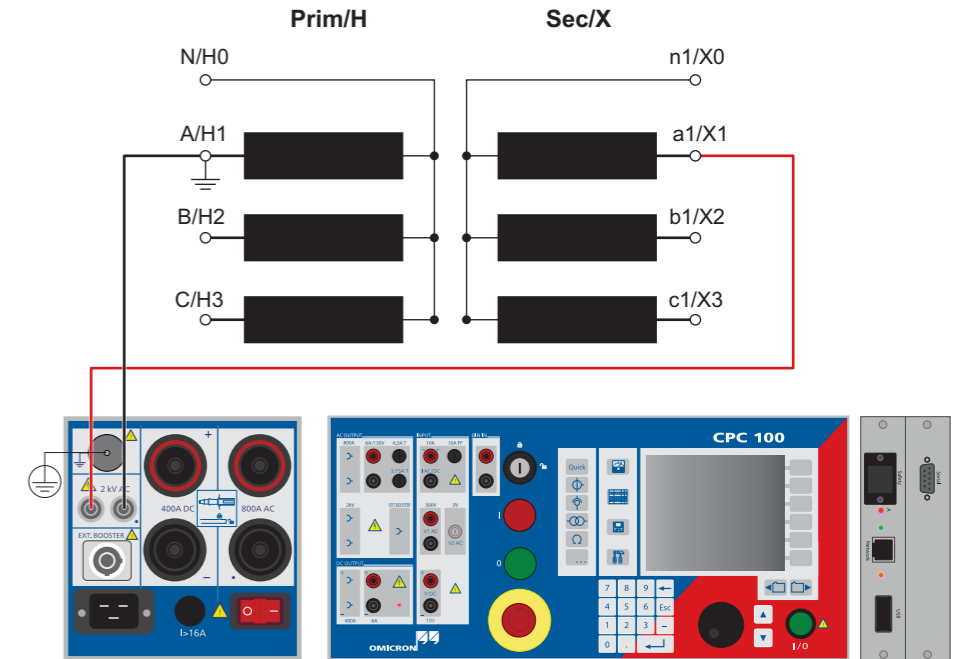

Demagnetization

Use the **Demag** test card to demagnetize the transformer core. Magnetized transformers may easily saturate and draw an excessive inrush current upon energization. Since the forces on the windings due to high inrush current may cause damage or even breakdown, it is desirable to avoid them.

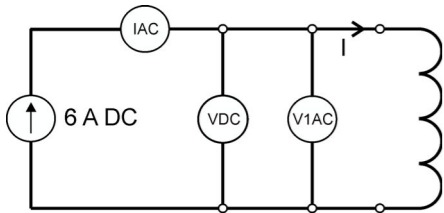

The **CPC 100 Demag** test card requires a **CP SB1** transformer switch box. The wiring is the same as for a standard resistance test plus a connection of the **V1** input to the switch box. Via the switch box, the **CPC 100** injects a constant current from the **6A DC** output into the power transformer. The current is led through the **IAC / DC** input for measurement.

Follow the steps below to fill in the **Demag** test card:

- ▶ Enter the vector group of the transformer.
- ▶ Specify whether the test object is a single-phase transformer.
- ▶ Enter the test current.

In the first step during the demagnetization process, the transformer core is saturated. This process stops at predefined thresholds. If a threshold is not reached over a long period of time, the saturation level can be adapted manually. By pressing **Set current saturat.**, the present saturation level can be set as the new threshold. During the **Demag** cycle, the initial remanence is measured and the currently remaining remanence is constantly displayed. After the test, the core is demagnetized.

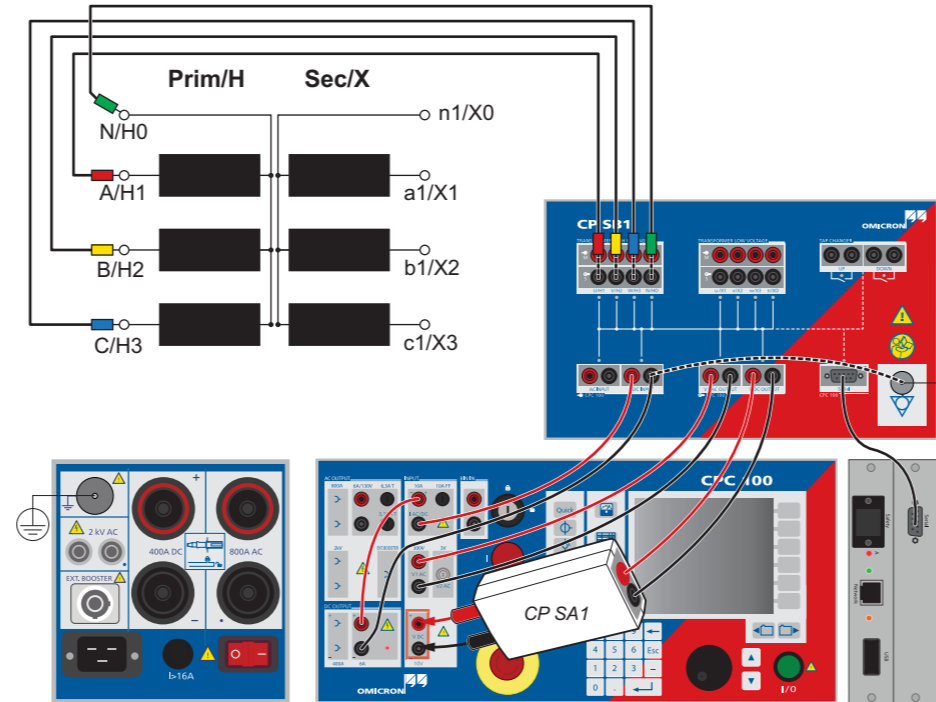

DANGER



Death or severe injury caused by high voltage or current

Injecting direct current into test objects with inductive characteristics will charge the winding of the test object.

- ▶ Follow instructions below.
- ▶ See section "DC output to test objects with a high inductance" on page Preface-4.

DANGER



Death or severe injury caused by high voltage or current

- ▶ Never open the measuring circuit while current flows.
- ▶ After a measurement, wait until the test device has discharged completely.
- ▶ Ground all poles of the test object before touching the test setup.
- ▶ Short-circuit the terminals before disconnecting the test leads.
- ▶ Disconnect cables not used for testing both from the test object and the test device.

Demagnetization

Quick 1 **Demag 1**

Wiring: Y zn 5

Single-phase transformer

I test: 0.500 A I meas.: 456.2 mA

Demag. progress

Saturating core... Sat. level: 99.0 %

Saturation: 78.1 %

min.: -100% max.: 100%

Assessed:n/a - On (100)

Min

Max

Set current saturat.

Back to Top

Test card during **Demag** process

Demag status messages:

Wiring check...	Checking for correct wiring
Idle.	Displayed before the process is started
Test was canceled.	Displayed after pushing the Emergency Stop button, confirming an error message or pressing the I/O button again
Saturating core...	Core is being saturated
Discharging...	Core is being discharged
Demagnetizing...	Actual demagnetization cycle in progress
Test stopped.	CPC 100 could not complete the demagnetization
Core is demagnetized.	Demag cycle has been successful

Resistance

CPC 100 User Manual

$\mu\Omega$ measurement

The **Resistance** test card provides a total of three output ranges. The test setup depends on the selected range.

1 $\mu\Omega$ to 10 m Ω

Setup for a $\mu\Omega$ measurement in the 400A DC range:

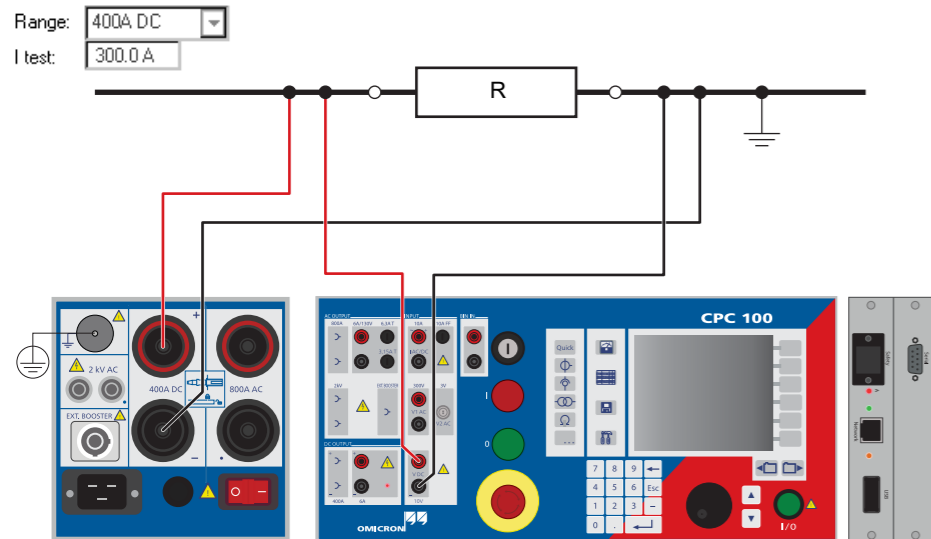

Inject current from the **400A DC** output to both sides of the test object. Input **V DC** measures the voltage drop, the software calculates the test object's resistance.

10 m Ω to 10 Ω

Setup for a m Ω measurement in the 6A DC range:

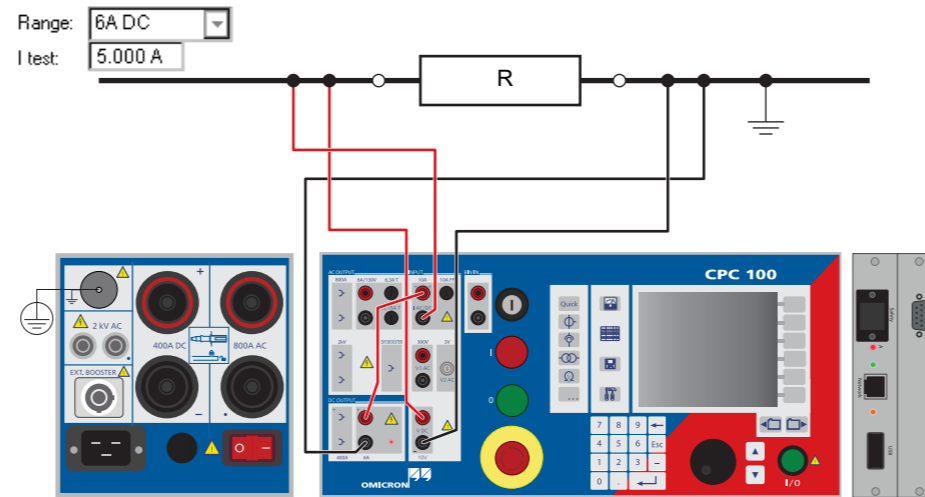

Inject current from the **6A DC** output to both sides of the test object. To measure this current, route it via the **I AC/DC** input as shown in the figure above. Input **V DC** measures the voltage drop, the software calculates the test object's resistance.

DANGER

Death or severe injury caused by high voltage or current

- ▶ Do not measure on a large inductance in this mode.
- ▶ Use **RWinding** instead.

10 Ω to 20 k Ω

Setup for an Ω to k Ω measurement in the V DC (2 wire) range:

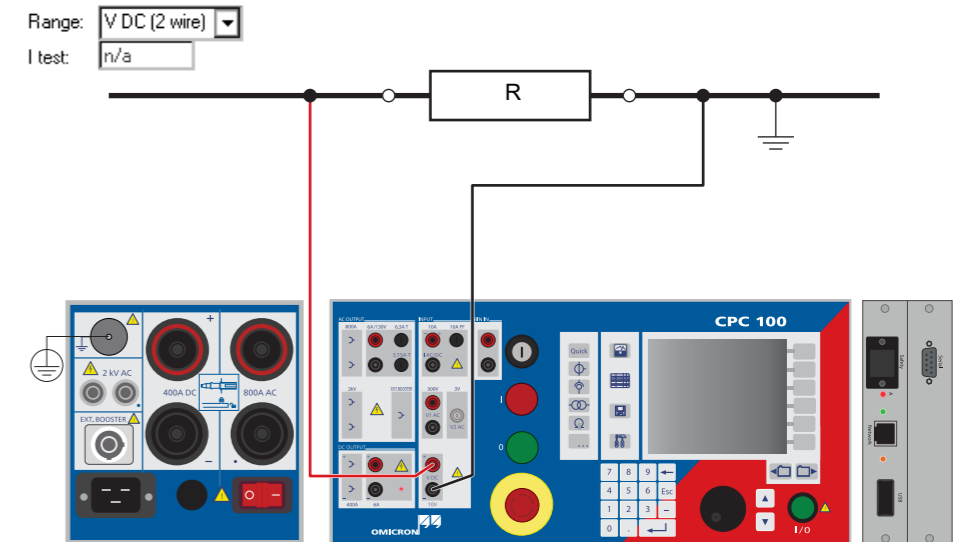

At this range, the DC input **V DC** outputs the current needed to measure the resistance.

μΩ measurement

Output range, select from 400A DC, 6A DC or V DC (2 wire)

Nominal test current ("n/a" if V DC 2 wire)

Smallest possible resistance

Actual test current that is injected into the test object

Measured voltage drop at the test object

Calculated resistance of test object, $R = V_{DC} / I_{DC}$

Select to stop test automatically when measurement is done

Highest possible resistance

Select to enter VDC manually instead of measuring it

Resistance 1 | RWinding 1 | TRTapCheck 1

Range: DC 400A

I test: 300.0 A Auto

R min: 700.0 nΩ R max: 16.67 mΩ

I DC: 299.99 A

V DC: 1.2850 V Manual input

R: 4.283 mΩ

Assessed: n/a

Buttons: Insert Card, Delete Card, Rename Card, Clear Results, Save As Default

Winding resistance

Use the **RWinding** test card to measure the resistance of a test object's secondary winding as described on page Transformer-5. Alternatively, inject the current directly from the **400A DC** output.

DANGER

Death or severe injury caused by high voltage or current

Injecting direct current into test objects with inductive characteristics will charge the winding of the test object.

- ▶ Follow instructions below.
- ▶ See section "DC output to test objects with a high inductance" on page Preface-4.

DANGER

Death or severe injury caused by high voltage or current

- ▶ Never open the measuring circuit while current flows.
- ▶ After a measurement, wait until the test device has discharged completely.
- ▶ Ground all poles of the test object before touching the test setup.
- ▶ Short-circuit the terminals before disconnecting the test leads.
- ▶ Disconnect cables not used for testing both from the test object and the test device.

WARNING

Death or severe injury caused by high voltage or current possible

It is recommended to perform all winding resistance measurements with the *CP SA1* connected to the *CPC 100* V DC input sockets to protect yourself and the *CPC 100* from high-voltage hazards.

- ▶ The *CP SA1* must be used for measurements using the **400A DC** output.
- ▶ Before disconnecting the test leads, short-circuit the test object's terminals first and then remove the wirings to the *CPC 100*.

Voltage Withstand Test

This test is identical to the voltage withstand test described on page Current Transformer-5.

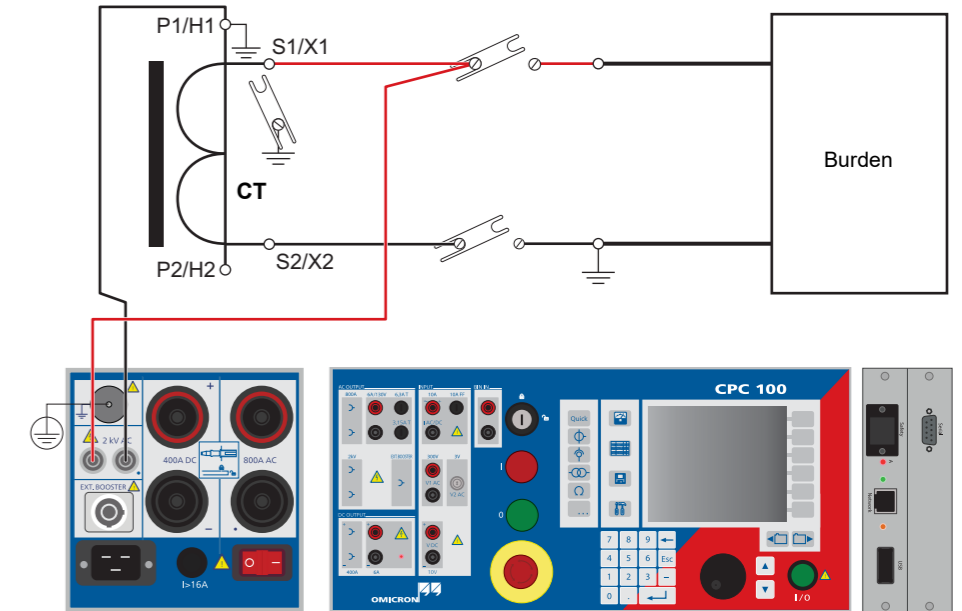

RGround

Use the **RGround** test card to determine earth resistance between a substation's ground system and a remote auxiliary electrode. To measure the earth resistance, the *CPC 100* injects AC current between the substation's ground system and a temporary remote auxiliary electrode. A second auxiliary electrode is used to measure the voltage potential across the substation's earth resistance.

Note: Make sure not to position the auxiliary electrode U too close to the substation's ground system. If you do so, you measure in a range where the earth resistance may not be linear (see figure below).

We suggest to test several points using a longer distance to the substation ground. That way you get a better understanding of where the linear range of the earth resistance lies, and where the measurements are reliable.

Theoretical resistance characteristic of an earth electrode:

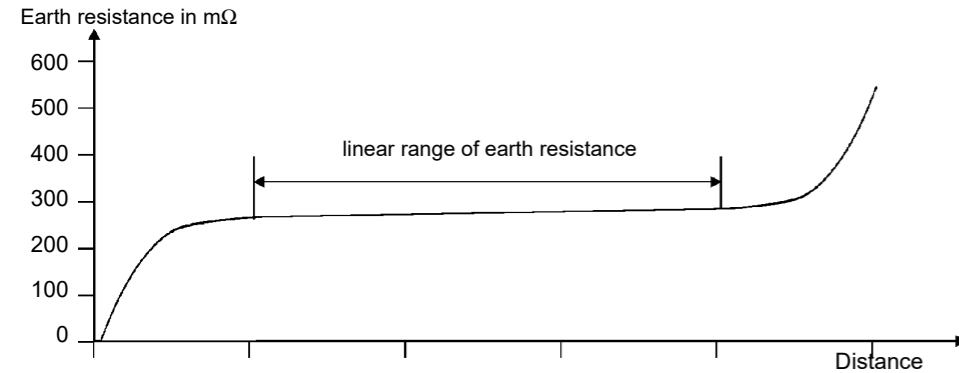

DANGER
Death or severe injury caused by high voltage or current

In case of a high-current ground fault within the substation during the test, considerably high voltages could arise in any wire connected to the substation and leading away from it.

- ▶ Do not touch the test probe without insulating gloves outside of the substation area.

WARNING
Death or severe injury caused by high voltage or current possible

The "Auxiliary electrode I" carries life threatening voltages during the test. Also the step voltage around the electrode can be quite high.

- ▶ Mark an area of 10 m (30 ft) around the electrode as dangerous zone and position a guard outside this area to keep people from entering the dangerous zone.
- ▶ If the desired current cannot be reached or an overload occurs, the contact resistance of the "Auxiliary electrode I" to the soil might be too high. Place several electrodes in a distance of a few meters and connect them all together to keep the resistance to the soil low. This also reduces the hazard due to high voltages around the electrode.

Measuring the ground resistance of small ground systems

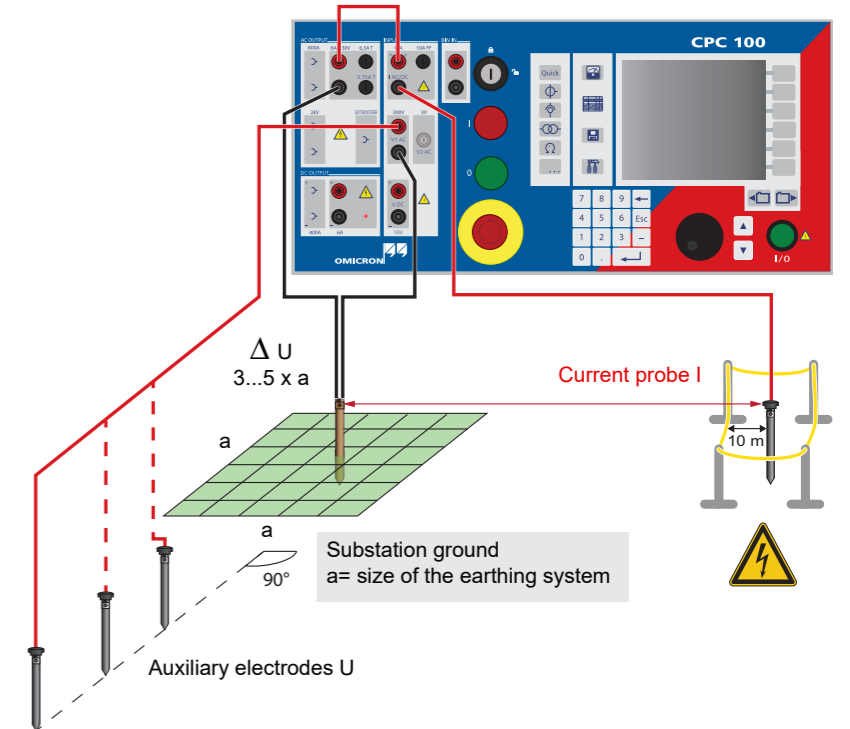

Note: Instead of injecting the test current via an auxiliary electrode, an existing line can be used (see page CP CU1-1).

RGround

Measuring the soil resistivity

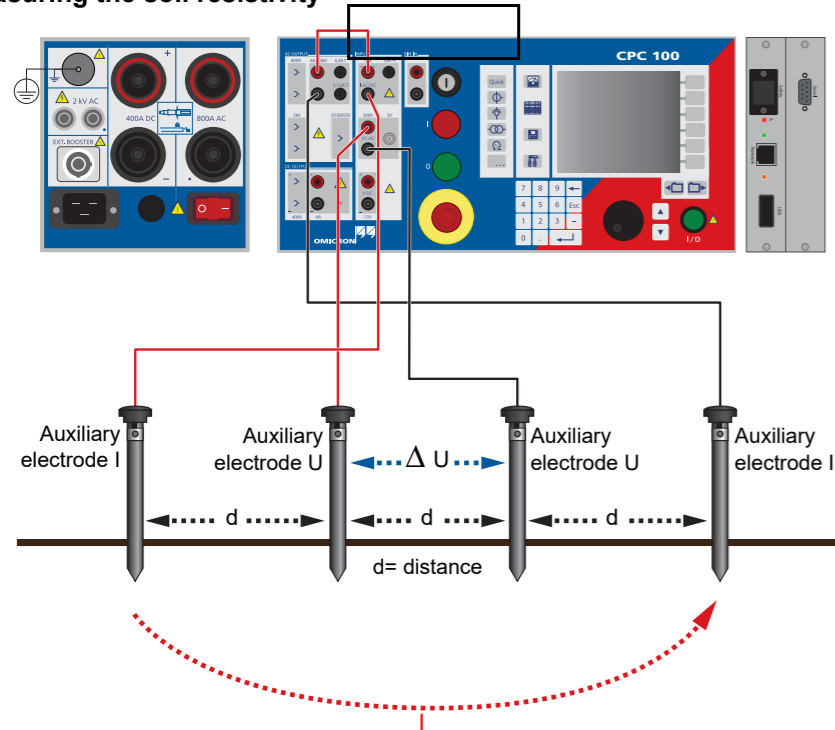

Calculating the soil resistivity:

$$\rho = 2 \pi d R$$

Legend:

ρ = soil resistivity

d = distance between auxiliary electrodes (identical between all electrodes)

R = calculated resistance as indicated at the **RGround** test card ($R(f)$)

With the spacing of "d", the test measures the average soil resistivity between the U auxiliary electrodes down to a depth of "d". Therefore, varying "d" also varies the depth of the volume for which the soil resistivity is to be measured.

DANGER

Death or severe injury caused by high voltage or current

▶ Do not touch the **6A AC** output. It can carry a life-threatening voltage level at high loop impedances or open measuring circuits.

Note: To learn how to measure the resistance of a single ground rod in an earthing system, refer to the CPC 100 Reference Manual, section "RGround" of chapter "Resistance". The CPC 100 Reference Manual is available in PDF format on the *CPC 100 Toolsets* or the *CPC 100 Start Page*.

Nominal test current

Frequency of test current. Select a frequency other than the 50 or 60Hz mains frequency to prevent interferences by stray earth currents.

Actual test current (rms value)

Measured voltage between substation ground and the auxiliary electrode U (rms value, non-selective frequency) and phase shift between VRMS and IRMS.

RWinding	TRTapCheck	RGround	Commer	Insert Card
I test:	1.000 A			Delete Card
f:	128.00 Hz			Rename Card
I RMS:	879.0 mA			Clear Results
V RMS:	474.5 mV	7.60 °		Save As Default
R(f):	228.3 mΩ	X(f):	21.93 mΩ	
Assessed:	n/a			

Calculated ohmic part of earth impedance (frequency-selective measurement)

Calculated inductive part of earth impedance (frequency-selective measurement)

Others: Sequencer

General

Use the **Sequencer** test card to define a sequence of states to be applied to a connected test object. A sequence of up to 7 states can be defined. The states within that sequence execute sequentially. For each state, a trigger signal can be specified to prematurely terminate this state and execute the next one.

A sequence of states can either be executed once from state 1 to state x, or repeated continuously. Furthermore, the complete sequence can prematurely be terminated if during the execution of one of its states this state's specified trigger condition occurs.

Switch off on trigger, i.e., abort sequence when the trigger condition becomes true

Synchronize with **V1 AC** (needs up to 200 ms to synchronize)

The sequence is repeated endlessly.***)

Output range selection

States table (state-specific settings):

- output quantity settings
- trigger specification*)
- duration of state if no trigger occurs**)

The screenshot shows the Sequencer test card interface. At the top, there are buttons for 'Quick', 'Sequencer', and 'Sequencer'. Below these are dropdown menus for 'AC 800A', 'S00T', and 'Repeat'. A table with 5 columns (A, Hz, Trigger, Thresh, s) contains three rows of state settings. Below the table are dropdown menus for 'I Out', 'I AC', 'Bin/Time', and 'Bin In'. On the right side, there are buttons for 'Insert Card', 'Delete Card', 'Rename Card', 'Clear Results', and 'Save As Default'. At the bottom, it says 'Assessed: n/a'.

A	Hz	Trigger	Thresh	s
9.5	50.00	Binary	n/a	5.000
799.0	55.00	I Out >	799.00	15.000
2.0	50.00	No Trigger	n/a	20.000

*) Note that some of the trigger events offered in the **trigger event** combo box depend on the measured quantity settings below (trigger on measurement).

Trigger on "Overload": the occurrence or the clearing of an output overload condition (clearing is delayed by 100 ms to debounce).

**)) Setting a time of 0.000 s makes the state infinite. Only a trigger signal will terminate it.

***)) This option can lead to a freeze of the *CPC 100* caused by a memory overflow. This can happen if there are too much results in a certain time. In this case, the *CPC 100* can only be switched off via the Emergency Stop button. The *CPC 100* will work properly again after rebooting the device.

Manual Trigger The feature **Manual Trigger** provides a possibility to manually initiate a trigger signal (i.e., a premature termination) of the current state at any time. This manual trigger has the same function as an automatic trigger signal.

Add State Press the **Add State** button to define additional states. Note that the maximum possible number of states is 6.

DANGER



Death or severe injury caused by high voltage or current

Together with the test object's capacitance, the leakage inductance of the *CPC 100*'s internal output transformer forms a series resonant circuit. Especially at frequencies > 50 / 60 Hz this may result in voltage super-elevation.

- ▶ When testing capacitive test objects using voltages ≥ 500 V, make sure that the test object's capacitance does not exceed 25 nF.

DANGER



Death or severe injury caused by high voltage or current

- ▶ Never use **Sequencer** in combination with a DC output on test objects with highly capacitive characteristics.
- ▶ Mind the danger of test object's charged capacitance. Before connecting or disconnecting any leads, use a grounding/discharging rod
 - ▶ to discharge all terminals of the test object.
 - ▶ to connect all terminals of the test object to ground and short-circuit all capacitances.

DANGER



Death or severe injury caused by high voltage or current

- ▶ Never use **Sequencer** to measure the resistance of windings with highly inductive characteristics. Turning off the DC source results in life-threatening voltage levels.
- ▶ For this kind of measurement only use the special winding resistance test cards **RWinding**, **TRTapCheck** or **OLTC-Scan**.

Testing an overcurrent relay with an ARC function

This sequence of four states tests a complete autoreclosure cycle with both a short dead time (rapid autoreclosure) and a long dead time (slow autoreclosure).

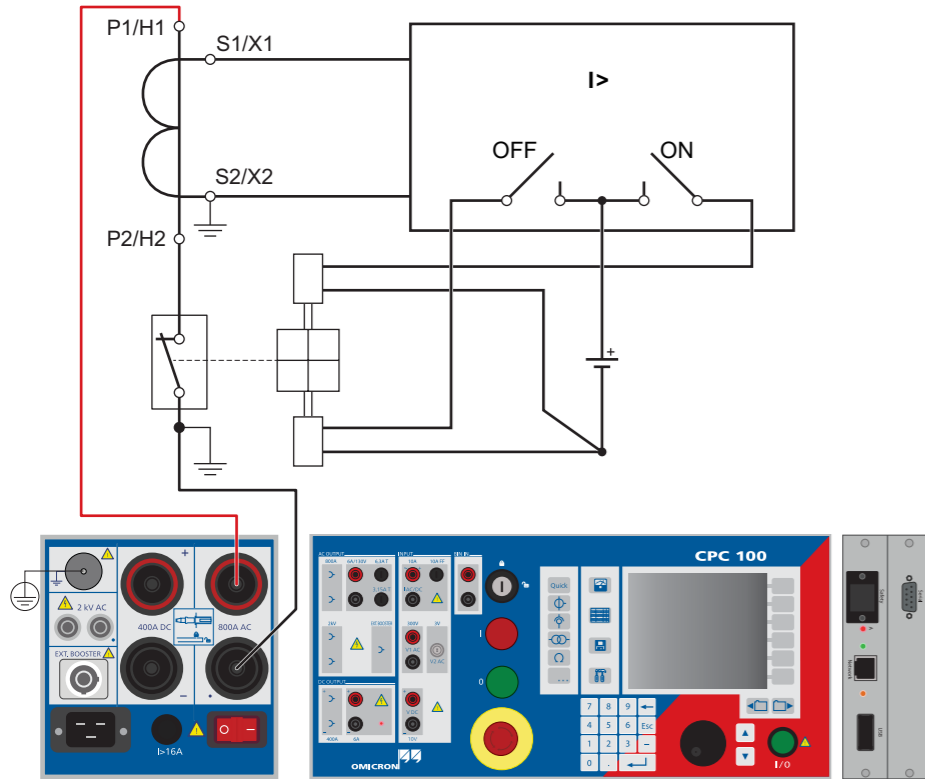

State 1: "wait for the CB to open"

Set to output 400A until the trigger condition "Overload" occurs.

Here, trigger condition "Overload" means: The CPC 100 cannot provide the 400A any longer because of the opening CB contact. Therefore, the opening CB contact terminates state 1.

The measurement table shows for state 1 that the relay time + the CB opening time lasted **290 ms**.

State 2: "wait for the CB to close"

Short dead time. Set to output 50A until the "Overload" trigger condition that started state 2 clears.

The measurement table shows for state 2 that the short dead time + the CB closing time lasted 477 ms. This time also includes the additional time to compensate for the debounce (see note).

The actual value for CB close equals 477 ms - 100 ms = **377 ms**.

Note that the r.m.s. measurement of IOut reacts slow and therefore the measurement table does not show the full current.

Quick		Sequencer		Sequencer		Sequencer		Sequencer	
A	Hz	Trigger	Thresh	s					
400.0	50.00	Overload	n/a	30.000					
50.0	50.00	Overload	n/a	30.000					
400.0	50.00	Overload	n/a	30.000					
50.0	50.00	Overload	n/a	30.000					

I Out		I AC		Bin/Time		Bin/Time	
A	*	A	*	Bin In	s		
399.8	0.00	xxx	xxx	○	290m		
35.6	0.00	xxx	xxx	○	477m		
399.8	0.00	xxx	xxx	○	291m		
35.6	0.00	xxx	xxx	○	3.1910		

Assessed: n/a

State 3: "wait for the CB to open"

Like state 1, see previous figure.

State 4: "wait for the CB to close"

Long dead time. Set to output 50A^{*)} until the "Overload" trigger condition that started state 4 clears.

The measurement table shows for state 4 that the long dead time + the CB closing time lasted 3.191 s. This time also includes the additional time to compensate for the debounce (see note).

The actual value for CB close equals 3.191 s - 100 ms = **3.091 s**.

^{*)} Current values < 50A do not initiate an "Overload" when the current circuit opens. For this reason, a nominal current value of 50A was chosen here, even though the CB is open.

Note: For debouncing purposes, at CB closing time measurements, the *CPC 100* adds a fixed time of 100 ms to the measured value. In order to determine the true CB closing time value, these 100 ms need to be deducted from the value displayed in the measurement table.

Time sequence of the four states to test the autoreclosure cycle

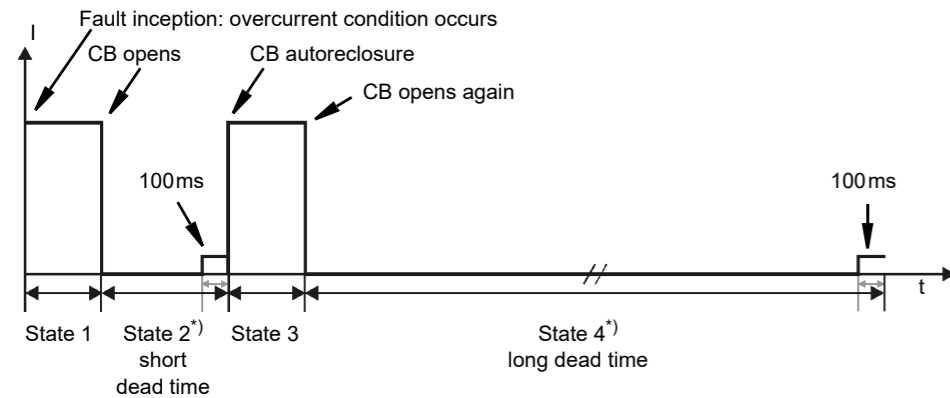

*) State 2 and 4 incl. the additional 100 ms the *CPC 100* adds to compensate for the debounce (see note above).

Others: Ramping

General

Use the **Ramping** test card to define a series of ramps to be applied to a connected test object. A series of up to 5 ramps can be defined. The ramps within that series execute sequentially, and run from a start to an end value within a set period of time.

It is possible to specify a trigger signal that prematurely terminates either the entire series of ramps or the actual ramp only, and then continues with the next one (if any).

Switch off on trigger, i.e., when a trigger condition becomes true

Output range selection & actual output value

Ramped quantity & fixed quantity

Ramps table (ramp-specific settings):

- output quantity settings
- ramp duration if no trigger occurs
- trigger specification

Quick	Sequencer	Sequencer	Ramping	Insert Card
AC 800A			<input type="checkbox"/> SDOOT	Delete Card
Amplitude	50.00 Hz	Start val:	1.0 A	Rename Card
A	s	Trigger	Thresh	Clear Results
200.0	5.000	No Trigger	n/a	Save As Default
200.0	10.000	Binary	n/a	
0.0	5.000	No Trigger	n/a	
I Out	I AC	Bin/Time		
A	*	A	*	Bin In
				s
Assessed: n/a				

Manual Trigger

The feature **Manual Trigger** provides a possibility to manually initiate a trigger signal (i.e., a premature termination) of the current ramp at any time. This manual trigger has the same function as an automatic trigger signal.

Add Ramp

Press the **Add Ramp** button to define additional ramps. Note that the maximum possible number of ramps is 5.

DANGER

Death or severe injury caused by high voltage or current

Together with the test object's capacitance, the leakage inductance of the *CPC 100*'s internal output transformer forms a series resonant circuit. Especially at frequencies > 50 / 60 Hz this may result in voltage superlevation.

- ▶ When testing capacitive test objects using voltages ≥ 500 V, make sure that the test object's capacitance does not exceed 25 nF.

DANGER

Death or severe injury caused by high voltage or current

- ▶ Never use **Ramping** in combination with a DC output on test objects with highly capacitive characteristics.
- ▶ Mind the danger of test object's charged capacitance. Before connecting or disconnecting any leads, use a grounding/discharging rod
 - ▶ to discharge all terminals of the test object.
 - ▶ to connect all terminals of the test object to ground and short-circuit all capacitances.

DANGER

Death or severe injury caused by high voltage or current

- ▶ Never use **Ramping** to measure the resistance of windings with highly inductive characteristics. Turning off the DC source results in life-threatening voltage levels.
- ▶ For this kind of measurement only use the special winding resistance test cards **RWinding**, **TRTapCheck** or **OLTC-Scan**.

Example of a series of ramps

Amplitude		50.00 Hz		Start val: 1.0 A		Delete Card		
A	s	Trigger	Thresh					
Ramp 1	200.0	5.000	No Trigger	n/a				
Ramp 2	200.0	10.000	Binary	n/a				
Ramp 3	0.0	5.000	No Trigger	n/a				

The three ramps defined in the ramps table shown above result in an output signal like this:

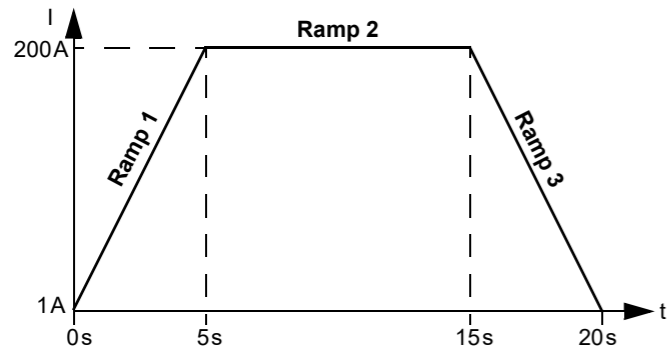

Ramp 1

from 1 A
(set at "Start val:")
to end value 200 A
(set in line 1 column "A")
in 5 s
(set in line 1 column "s")

Ramp 2

from 200 A
(end value of ramp 1)
to end value 200 A
(set in line 2 column "A")
for 10 seconds
(set in line 2 column "s")

Ramp 3

from 200 A
(end value of ramp 2)
to end value 0 A
(set in line 3 column "A")
in 5 seconds
(set in line 3 column "s")

Testing the pick-up / drop-off value of an overcurrent relay

To determine the pick up and the drop off value of a relay, a series of three ramps is defined. The first ramp determines the pick up value, the second one represents a 1 s pause time, and the third ramp determines the drop off value.

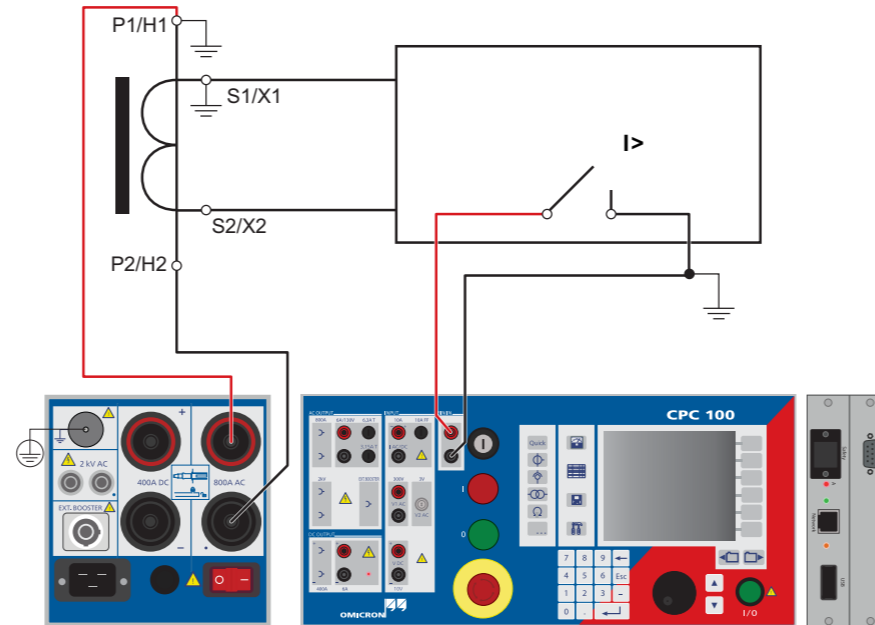

The CPC 100's AC OUTPUT feeds the ramped current signal into a CT, which is connected to an overcurrent relay. The overcurrent relay's trip contact is fed into the CPC 100's binary input BinIn, and acts there as a trigger signal.

Ramp 1:

Set to output a ramped current signal from 100.0A to either 200.0A in 10s, or until the trigger condition "Binary" occurs. Here, trigger condition "Binary" means: the relay contact picks up. In this moment, ramp 1 terminates and the series continues with ramp 2. The measurement table shows for ramp 1 that the relay contact picked up after 7.175s at a current value of 170.29A

Ramp 2:

Pause time. Test current output is "frozen" for 1 s.

Quick		Sequencer		Sequencer		Ramping		Insert Card		
AC 800A		50.00 Hz		Start val: 100.0 A		SOOT		Delete Card		
A	s	Trigger	Thresh							
200.0	10.000	Binary	n/a							
200.0	1.000	No Trigger	n/a							
0.0	10.000	Binary	n/a							
I Out	I AC	Bin In	Bin Time							
170.29	0.00	xxx	xxx	7.1750						
170.29	0.00	xxx	xxx	1.0000						
152.35	0.00	xxx	xxx	1.1000						
Assessed: n/a										

Ramp 3:

Because ramp 1 did not reach the 200A due to the trigger signal, ramp 3 starts with 170.29A, and then ramps down to zero with the set steepness (200.0A to 0.0A in 10s) until the trigger condition "Binary" occurs. Here, trigger condition "Binary" means: the relay contact drops off. Since there are no further ramps defined, in this moment the sequence terminates. The measurement table shows for ramp 3 that the relay contact dropped off 1.1s after ramp 3 started at a current value of 152.35A.

Others: Amplifier

Time sequence of the three ramps:

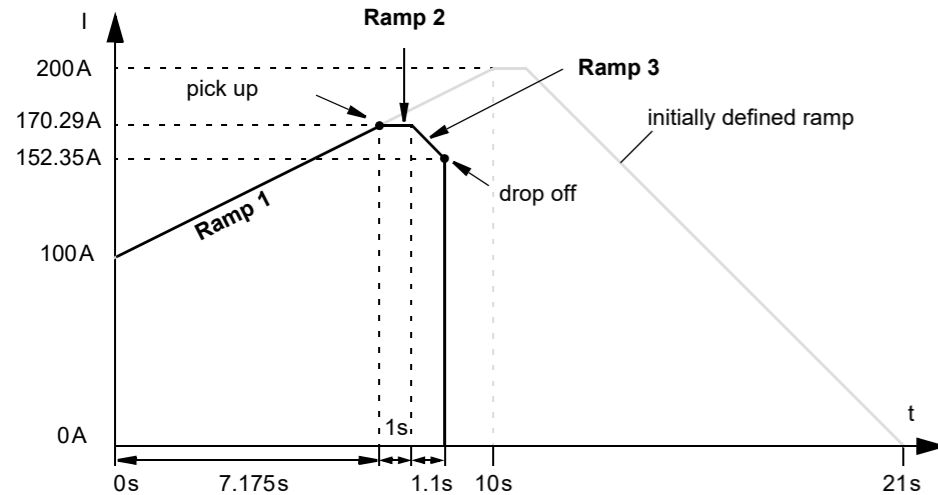

General

Use the **Amplifier** test card to set the *CPC 100* to an "amplifier-like" mode. In this mode, an input signal fed into a synchronization input drives the high-current output's magnitude, frequency and phase angle.

Select between **I AC**, **V1 AC** and **V2 AC** as synchronization inputs.

To prevent saturation, the output signal follows sudden magnitude changes at the synchronization input slowly. This smoothening effect delays the follow-up of the output current up to 250 ms.

Both the "amplification" factor and the phase angle between input and output are set by the user in the **Amplifier** test card.

Note: Changes in frequency and phase angle may result in unwanted effects. Both frequency and phase must be held stable.

Note: The input frequency is limited to a range of 48 ... 62 Hz.

The screenshot shows the 'Amplifier' test card interface. The 'Range' is set to 'AC 800A'. The 'Phase' is set to '0.00°'. The 'Sync. Input' is set to 'V1 AC'. The 'Amplif. factor' is set to '2.0 A/V'. The 'Measured output' is displayed as '200.1 A'. The 'Measured input' is '100.1 V'. The 'Measured input frequency' is '55.0 Hz'. The interface includes buttons for 'Insert Card', 'Delete Card', 'Rename Card', 'Save As Default', and 'Settings'. Annotations include: 'Set range' pointing to the Range dropdown; 'Set phase angle between input and output signal' pointing to the Phase input; 'Select synchronization input' pointing to the Sync. Input dropdown; 'Measured input frequency (48 ... 62 Hz)' pointing to the frequency display; 'Display of the measured high-current output signal' pointing to the large '200.1 A' display; 'Measured phase angle between input and output signal' pointing to the phase display; and 'Value measured at synchronization input (refer to "Starting a high-current output" in the next column)' pointing to the 'Measured input' display.

Set the amplification factor to determine the ratio between input and output signal.

Note: The synchronization input is not automatically range-switching, it is fixed to its maximum value.

Starting a high-current output

DANGER
Death or severe injury caused by high voltage or current

Depending on the measured input signal, setting the amplification factor can result in unintentionally high currents.

▶ If the magnitude of the input signal is unknown or uncertain, set the amplification factor to "0" before starting the test.

▶ Set an amplification factor of "0".



▶ Press I/O (test start / stop) to start the measurement.
 ▶ Now the display field shows the measured input value.

▶ With the measured input value in mind, enter the amplification factor now.

▶ Acknowledge this entry by pressing the handwheel or the Enter key to start the output.

Amplifier use case: GPS-synchronized 3-phase system for end-to-end testing

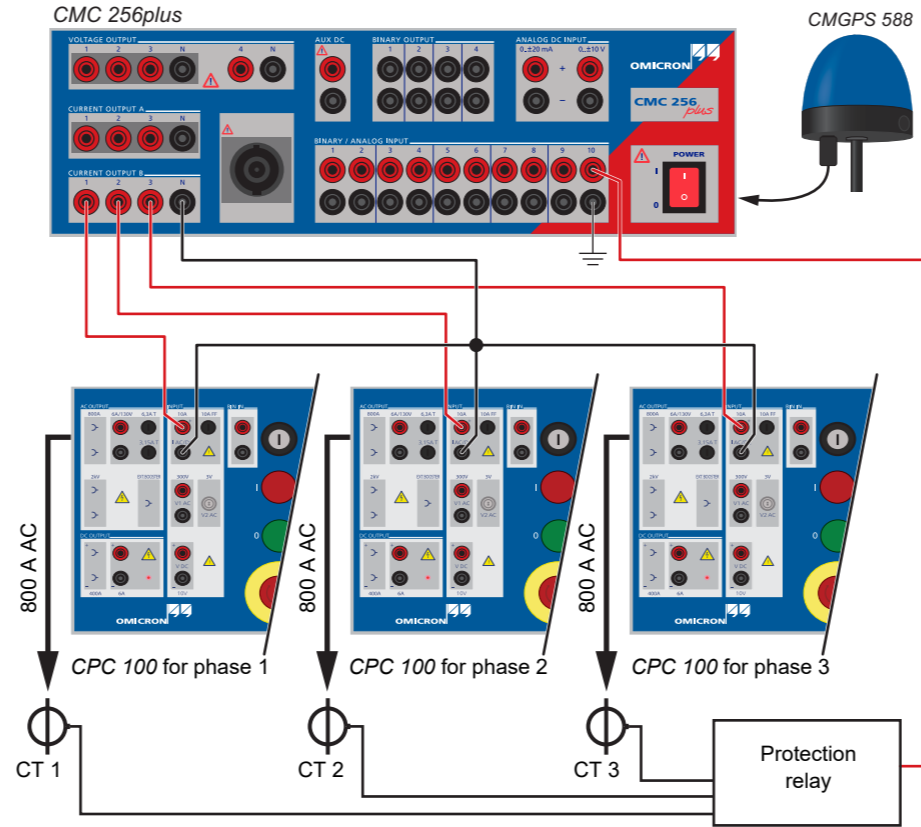

This example shows how the three current outputs of a *CMC 256plus* test set are led to the synchronization inputs **I AC** of three *CPC 100* test sets to drive their high-current outputs. This way, the *CPC 100* high-current outputs represent the "amplified" *CMC 256plus* outputs and, in this example, are connected to three CTs.

Settings of **Amplifier** test card for this example use case:

Quick	Amplifier	Insert Card
Range:	AC 800A	Measured output:
		460.0 A
Phase:	0.00 °	0.02 °
Sync. Input:	I AC	Measured input:
		4.600A
Amplification factor:	f:	
100.0 A/A	55.0 Hz	
Assessed:n/a		Save As Default

The **Comment** card is inserted to a test procedure in the same manner like a test card. Its purpose is to hold a user-defined comment and / or note regarding the actual test procedure or other important information, such as operational data of a transformer, for example.

Others: Comment

Starting the string editor

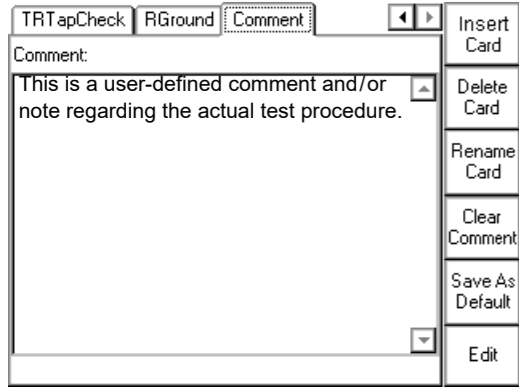

Press the context-dependent menu key **Edit** to start the *String Editor*, the tool for entering text.

When used for the **Comment** card, the *String Editor* differentiates between the input modes "Form Editor" and "Text Editor". After pressing **Edit**, "Text Editor" is active. With the exception of the context-dependent menu key to switch between these two modes, the user interface is identical.

To create "flowing" text with no tabs in it, either input mode can be used. Compose a text of your choice by selecting the individual characters and symbols needed one by one and confirm them by pressing the handwheel. When finished, acknowledge with **OK**.

To create such a "2 columns" layout use the Form Editor.

Form editor - text editor

Sub.:	Buers
Trans.:	TR24
Manuf.:	Siemens
Type:	KFRM 1863A / 22E
Year:	1955
Se. No.:	T-54953
Power:	100 MVA
VecGr.:	YN/yn0
Uprim:	220.000 V
Iprim:	262.5 A
Usec:	110.000 V
Isec:	525.0 A
Uk:	10.2 %

Enter the first word "Substation" and then a tab. Proceed with "Buers" and a carriage return. Proceed accordingly:

Sub.	→H	Buers	↑↓
Trans.	→H	TR24	↑↓
Manuf.	→H	Siemens	↑↓
Type	→H	a.s.o.	↑↓

The tab quasi denotes a column-break.

The difference between Form Editor and Text Editor is that text left of the tab (the "first column", so to speak) cannot be accessed anymore in Text Editor, i.e., it is protected. To add, edit or delete first column entries use the Form Editor.

How to change a comment

If you need to change an existing comment, press **Edit**. This starts the *String Editor*.

Start the appropriate input mode, "Form Editor" or "Text Editor", change the entries of your choice and press **OK**.

How to clear a comment

Press **Clear Comment**. The context-dependent menu keys change and provide two more keys: **Clear All** and **Clear Text**.

Clear All: Deletes the entire comment at once, i.e. all text in all columns.

Clear Text: Deletes all to the right of the tab, i.e. everything but the left-hand side column.

Others: HV Resonance Test System

CPC 100 User Manual

General

The **HV Resonance Test System** test card is used for generic high-voltage tests on GIS with a resonance circuit in combination with the *CP RC1* or the *CP RC2*.

The main interface displays the following elements:

- Output voltage:** 0.0 kV
- Frequency:** 60.00 Hz
- Search f0:** Search f0...
- Ratio estim.:** 1000.0 : 1
- Test cycle:** Test cycle...
- Controlled input channel:** VT, CT, V out, I out, °, Time
- Buttons:** Insert Card, Delete Card, Rename Card, Clear Results, Save As Default, Settings
- Assessed:** n/a
- Time elapsed for this measurement:** (displayed at the bottom)
- Output voltage at CPC 100 Ext. Booster output:** (displayed at the bottom)
- Output current at CPC 100 Ext. Booster output:** (displayed at the bottom)

Test settings

The Test settings dialog box includes the following parameters and options:

- Nominal CT ratio according to CT nameplate:** I AC, 1000.0 A, 1.0000 A
- Nominal VT ratio according to VT nameplate:** V1 AC, 110.0 kV, 110.0 V
- Short-circuit impedance of the power VT at 100 Hz:** X sc@100Hz: 100.0 mΩ
- Estimated power VT ratio with losses:** VT ratio w/ loss=: 110.0 kV, 110.0 V
- Options:** Estimate HV@f0 = n/a
- Buttons:** Insert Card, Delete Card, Rename Card, Clear Results, Save As Default, Main Page
- Circuit Diagram:** Shows a resonance circuit with components: CPC, TRx, CRx, CT, VT, GIS, VT, V1AC.

Note: Refer to the *CP RC1* and *CP RC2* User Manuals for information on the correct test setup and connection.

To set the test cycle:

The Test cycle configuration dialog box includes the following settings and a table:

- Test cycle:** Test cycle
- Slope:** 5.0 kV/s
- Table:**

V	Time
10.0k	10.0s
100.0k	10.0s
10.0k	10.0s
- t cycle:** 1' 10"
- Buttons:** Add State, Delete Last, s, min, h, Back to Top, OK

DANGER



Death or severe injury caused by high voltage

- ▶ Do not connect a reactor in serial with the *CP TR7/CP TR8* output.

NOTICE

Equipment damage caused by high test current

- ▶ Verify that the voltage transformer used for the high-voltage generation can withstand the needed test current.
- ▶ Observe the maximum operating time of the VT and the *CP RC1*. Refer to the corresponding manuals for more information.

Common functions

Test assessment

The test assessment is a manual procedure carried out by the user.

The example below shows an assessment made at a **VTRatio** test card. However, the assessment procedure is carried out in the same fashion on all test cards.

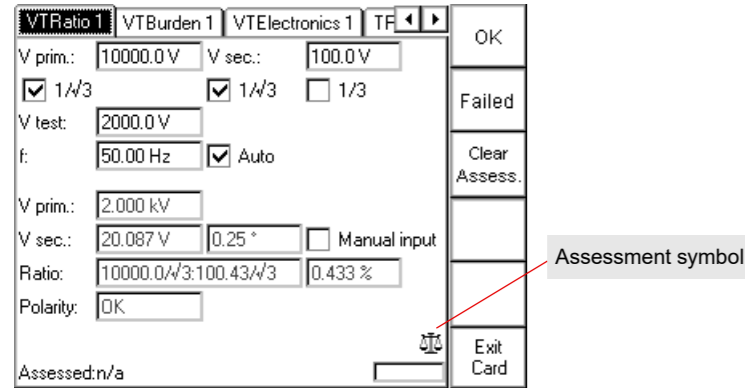

- ▶ After the test, set the focus on the assessment symbol by turning the handwheel.



Test not assessed.

- ▶ Use the context-dependent menu keys to assess the test.



Test OK



Test failed

The String Editor

The *String Editor* is used to name or rename test cards, tests and templates as well as to fill out the **Comment** card.

Any time such an operation becomes necessary, the *String Editor* starts automatically.

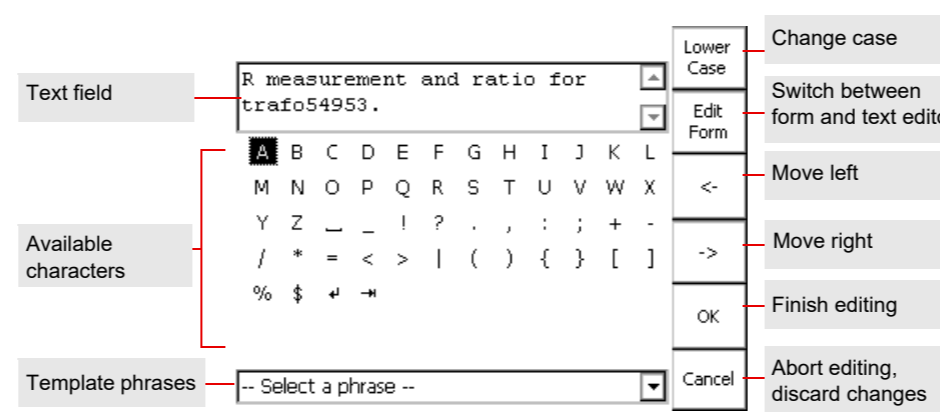

The number of available characters to choose from depends on the *String Editor's* use. If, for example, a user-defined comment is to be entered in the **Comment** card, the number of available characters is bigger than if a test is to be renamed. This difference are special characters, such as !, ?, ., , [], etc.

Important special characters

↵ carriage return (line feed)

→ tab (special function in Form Editor mode; refer to page Others-7).

Complete the following steps to change the default name, and to enter a name of your choice:



- ▶ Delete the default name by repeatedly pressing the backspace key.



- ▶ Enter the new test or folder name by consecutively selecting the characters of your choice from the "on-screen keyboard" with the **Up / Down** keys or by navigating to it with the handwheel.
- ▶ Acknowledge every selected character by pressing the handwheel or **Enter**.

Template phrases

The *String Editor* provides a feature, that allows you to save phrases, i.e., names of test cards, tests, templates, folders and files. Once these phrases are saved, they can then be selected as template phrases from the **Select a phrase** combo box.

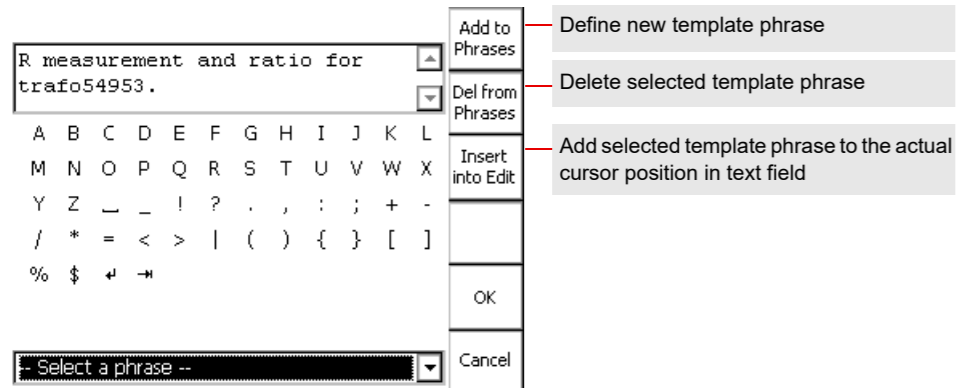

How to save a phrase

- ▶ Enter a name of your choice in the way described above.
- ▶ Put the focus on the **Select a phrase** combo box.
- ▶ Press **Add to Phrases** to add this name to the list of template phrases.

CPC 100 technical data

CPC 100 User Manual

Generator / output section - current outputs

Note: For detailed information refer to the section "Technical Data" in the CPC 100 Reference Manual available in pdf format on the *CPC 100 Toolsets* or the *CPC 100 Start Page*.

The output is either voltage or current, and is automatically selected by the software or manually by the user. Current and voltage outputs are overload and short-circuit proof and protected against over-temperature.

Range	Amplitude	t _{max} ¹	V _{max} ²	Power _{max} ²	f
800A AC ³	0 ... 800 A	25 s	6.0 V	4800 VA	15 ... 400 Hz
	0 ... 400 A	8 min	6.4 V	2560 VA	15 ... 400 Hz
	0 ... 200 A	> 2 h	6.5 V	1300 VA	15 ... 400 Hz
6A AC ¹⁰	0 ... 6 A	> 2 h	55 V	330 VA	15 ... 400 Hz
3A AC ¹⁰	0 ... 3 A	> 2 h	110 V	330 VA	15 ... 400 Hz
400A DC	0 ... 400 A	2 min	6.5 V	2600 VA	DC
	0 ... 300 A	3 min	6.5 V	1950 VA	DC
	0 ... 200 A	> 2 h	6.5 V	1300 VA	DC
6A DC ^{4, 10}	0 ... 6 A	> 2 h	60 V	360 VA	DC

2000A AC³ with an optional current booster. For more details, refer to page CP CB2-1.

Generator / output section - voltage outputs

Range	Amplitude ⁵	t _{max}	I _{max}	Power _{max} ⁵	f
2kV AC ³	0 ... 2 kV	1 min	1.25 A	2500 VA	15 ... 400 Hz
	0 ... 2 kV	> 2 h	0.5 A	1000 VA	15 ... 400 Hz
1kV AC ³	0 ... 1 kV	1 min	2.5 A	2500 VA	15 ... 400 Hz
	0 ... 1 kV	> 2 h	1.0 A	1000 VA	15 ... 400 Hz
500V AC ³	0 ... 500 V	1 min	5.0 A	2500 VA	15 ... 400 Hz
	0 ... 500 V	> 2 h	2.0 A	1000 VA	15 ... 400 Hz
130V AC ¹⁰	0 ... 130 V	> 2 h	3.0 A	390 VA	15 ... 400 Hz

Output transient characteristics

	Changes from "off" or a low magnitude to a higher magnitude	Changes from a high magnitude to a lower magnitude or "off"
AC current	within one period	300 ms maximum; accordingly less for smaller magnitudes
AC voltage	1200 ms maximum; accordingly less for smaller magnitudes	300 ms maximum; accordingly less for smaller magnitudes

Internal measurement of outputs

Output	Range	Guaranteed accuracy			Typical accuracy ⁶		
		Amplitude		Phase	Amplitude		Phase
		Reading error	Full scale error	Full scale error	Reading error	Full scale error	Full scale error
800A AC	-	0.20 %	0.20 %	0.20°	0.10 %	0.10 %	0.10°
400A DC	-	0.40 %	0.10 %	-	0.20 %	0.05 %	-
2kV AC	2000 V	0.10 %	0.10 %	0.20°	0.05 %	0.05 %	0.10°
	1000 V	0.10 %	0.10 %	0.30°	0.05 %	0.05 %	0.15°
	500 V	0.10 %	0.10 %	0.40°	0.05 %	0.05 %	0.20°
	5 A	0.40 %	0.10 %	0.20°	0.20 %	0.05 %	0.10°
	500 mA	0.10 %	0.10 %	0.20°	0.05 %	0.05 %	0.10°

Note: For the individual notes, see "Notes related to inputs and outputs" below.

Measuring inputs

Input	Imped.	Range	Guaranteed accuracy			Typical accuracy ⁶		
			Amplitude		Phase	Amplitude		Phase
			Reading error	Full scale error	Full scale error	Reading error	Full scale error	Full scale error
IAC/DC ^{4, 7}	< 0.1 Ω	10A AC	0.10 %	0.10 %	0.20°	0.05 %	0.05 %	0.10°
		1A AC	0.10 %	0.10 %	0.30°	0.05 %	0.05 %	0.15°
		10A DC	0.05 %	0.15 %	-	0.03 %	0.08 %	-
		1A DC	0.05 %	0.15 %	-	0.03 %	0.08 %	-
V1 AC ⁸	500 kΩ	300 V	0.10 %	0.10 %	0.20°	0.05 %	0.05 %	0.10°
		30 V	0.10 %	0.10 %	0.20°	0.05 %	0.05 %	0.10°
		3 V	0.20 %	0.10 %	0.20°	0.10 %	0.05 %	0.10°
		300 mV	0.30 %	0.10 %	0.20°	0.15 %	0.05 %	0.10°
V2 AC ^{8, 11}	10 MΩ	3 V	0.05 %	0.15 %	0.20°	0.03 %	0.08 %	0.10°
		300 mV	0.15 %	0.15 %	0.20°	0.08 %	0.08 %	0.10°
		30 mV	0.20 %	0.50 %	0.30°	0.10 %	0.25 %	0.15°
V DC ^{4, 7}		10 V	0.05 %	0.15 %	-	0.03 %	0.08 %	-
		1 V	0.05 %	0.15 %	-	0.03 %	0.08 %	-
		100 mV	0.10 %	0.20 %	-	0.05 %	0.10 %	-
		10 mV	0.10 %	0.30 %	-	0.05 %	0.15 %	-

Output to input synchronization

	Test cards Quick, Sequencer, Ramping	Test card Amplifier
Frequency range	48 ... 62 Hz	
Synchronization inputs	V1 AC (automatic range switching)	V1 AC, V2 AC, I AC (fixed to maximum range)
Input magnitude	10 % of input range full scale	
Output magnitude	5 % of output range full scale	
Settling time	100 ms after 5 % of output magnitude is reached	1000 ms after 5 % of output magnitude is reached
Signal changes	All quantities must be ramped within 20 signal periods	No changes of frequency and phase. Magnitude changes without limitation. Output follows within 250 ms.
Phase tolerance	0.5° within the limits as specified above	

Notes related to inputs and outputs

All input/output values are guaranteed over one year within an ambient temperature of 23 °C ± 5 ° (73 °F ± 10 °F), a warm-up time longer than 25 min and in a frequency range of 45 ... 60 Hz or DC. Accuracy values indicate that the error is smaller than ± (value read x reading error + full scale of the range x full scale error).

1. With a mains voltage of 230 V using a 2 x 6 m high-current cable at an ambient temperature of 23 °C ± 5 ° (73 °F ± 10 °F)
2. Signals below 50 Hz or above 60 Hz with reduced values possible.
3. Output can be synchronized with V1 AC in **Quick, Sequencer, Ramping** and **Amplifier**.
4. The input / output is protected with lightning arrestors between the connector and against protective earth. In case of energy above a few hundred Joule the lightning arrestors apply a permanent short-circuit to the input / output.
5. Signals below 50 Hz or above 200 Hz with reduced values possible.
6. 98 % of all units have an accuracy better than specified as *typical*.
7. Input is galvanically separated from all other inputs
8. V1 and V2 are galvanically coupled but separated from all other inputs.
9. There are power restrictions for mains voltages below 190V AC.
10. Fuse-protected
11. When using the **CTRogowski** test card, the 3V **V2 AC** input uses an additional software based integration method. In the range of 50 Hz < f < 60 Hz, this results in a phase shift of 90° as well as an additional phase error of +/- 0.1° and an additional amplitude error of +/- 0.01 %. For frequencies in the range of 15 Hz < f < 400 Hz, the phase error is not specified, and the amplitude error can be up to +/- 0.50 % higher.

Measuring inputs

Additional features of the measuring inputs

- Automatic range switching (except test card **Amplifier**)
- Galvanically separated potential groups: **I AC / DC**; **V1 & V2**; **V DC**
- AC frequency range 15 ... 400 Hz (except test card **Amplifier**)
- Protection of **I AC / DC** input: 10A FF fuse⁴

Binary input for dry contacts or voltages up to 300V DC⁷

Trigger criteria	Toggling with potential-free contacts or voltages of up to 300 V
Input impedance	> 100 kΩ
Response time	1 ms

Resistance measurement

The accuracy of the resistance measurements can be calculated from the respective input and output specifications.

4-wire measurement with 400A DC output and 10V VDC input				
Current	Resistance	Voltage	Typ. error	Guaranteed
400 A	10 μΩ	4 mV	0.70 %	1.35 %
400 A	100 μΩ	40 mV	0.55 %	1.10 %
400 A	1 mΩ	400 mV	0.50 %	0.95 %
400 A	10 mΩ	4 V	0.50 %	0.95 %
4-wire measurement with 6A DC output and 10V VDC input				
Current	Resistance	Voltage	Typ. error	Guaranteed
6 A	100 mΩ	0.6 V	0.35 %	0.60 %
6 A	1 Ω	6 V	0.35 %	0.60 %
1 A	10 Ω	10 V	0.25 %	0.40 %
2-wire measurement with 10V VDC input				
Current	Resistance	Voltage	Typ. error	Guaranteed
< 5 mA	100 Ω		0.60 %	1.20 %
< 5 mA	1 kΩ		0.51 %	1.02 %
< 5 mA	10 kΩ		0.50 %	1.00 %

General

Display	¼ VGA greyscale LCD display
Power supply	
Single-phase, nominal ⁹	100V AC ... 240V AC, 16A
Single-phase, permissible	85V AC ... 264V AC (L-N or L-L)
Frequency, nominal	50/60 Hz
Power consumption	< 7000 VA for a time < 10 s
Connection	IEC320/C20

Environmental conditions

Climate		
Temperature	Operating	-10 °C ... +55 °C / +14 °F ... +131 °F
	Storage	-30 °C ... +70 °C / -22 °F ... +158 °F
Max. altitude	Operating	2,000 m / 6,550 ft
	Storage	12,000 m / 40,000 ft

Standards conformity

EMC, safety	
EMC	IEC/EN 61326-1 (industrial electromagnetic environment) FCC subpart B of part 15, class A
Safety	IEC/EN/UL 61010-1, IEC/EN/UL 61010-2-30



Note: This only applies to devices that have the respective indication on their nameplate.

Other	
Shock	IEC/EN 60068-2-27 (15 g/11 ms, half-sinusoid, 3 shocks in each axis)
Vibration	IEC/EN 60068-2-6 (frequency range 10 Hz ... 150 Hz, acceleration 2 g continuous (20 m/s ² /65 ft/s ²), 20 cycles per axis)
Humidity	IEC/EN 60068-2-78 (5 % ... 95 % relative humidity, no condensation), tested at 40 °C/104 °F for 48 hours
Protection class	IP22 (in upright position) according to IEC/EN 60529

Mechanical data

Characteristic	Rating
Dimensions (w × h × d)	468 × 394 × 233 mm 18.6 × 15.5 × 9.2 in
Weight	29 kg/64 lb case without protection cover

Safety instructions

The *CP TD*'s output and the connected cables carry life-hazardous voltage or current.

- ▶ Obey the five safety rules and follow the detailed safety instructions in the CP TD User Manuals.

Note: The safety instructions relevant to the *CPC 100* and its accessories (refer to page Preface-1) also apply to the *CP TD*. This section lists safety instructions that exclusively apply to the *CP TD*.

- ▶ Do not operate the *CP TD* with unconnected shield of the high-voltage cable.
- ▶ If the **Perform shield check** check box is cleared, make sure that the shield is connected before operating the *CP TD*.

Handling cables

- ▶ Do not use any other cables than the ones supplied by OMICRON electronics.
- ▶ Do not connect any cable to the test object without a visible grounding of the test object.
- ▶ Never remove *any* cables from the *CP TD* or the test object during a test.
- ▶ Always turn off the *CP TD* completely before you connect or disconnect any cable (disconnect the *CPC 100* from mains or press its Emergency Stop button).
- ▶ The high-voltage cable must always be well attached and tightly connected to both the *CP TD* and the test object. A loose or even falling off connector at the test object carrying high voltage is life-hazardous. Make sure the connectors are clean and dry before connecting.
- ▶ At the *CP TD*, press the high-voltage cable's plug to the connector tightly and turn the screw cap until you feel a mechanical stop. If you notice a rough-running of the screw-cap, clean the screw thread and use a lubricant (vaseline recommended).
- ▶ Tighten the plugs manually. Do not use any tools for that because that can damage the plugs or connectors.
Insert the yellow banana plug (the high-voltage cable's grounding) into the respective plug socket.

- ▶ The high-voltage cable is double-shielded and therefore safe. However, the last 50 cm (20 inch) of this cable have no shield. Therefore, during a test consider this cable a life wire and due to the high voltage life-hazardous.
- ▶ Keep clear from zones in which high voltages may occur. Set up a barrier or establish similar adequate means.
- ▶ Both low-voltage measuring cables must always be well attached and tightly connected to the *CP TD*'s measuring inputs IN A and IN B.
Make sure to insert the red and blue marked cables into the corresponding measuring inputs: IN A = red, IN B = blue.
Tighten the plugs by turning them until you feel a stop.
- ▶ Tighten the plugs manually. Do not use any tools for that because that can damage the plugs or connectors.

Product description - designated use

The *CP TD* (*CP TD1*, *CP TD12* or *CP TD15*) is an optionally available high-precision test system for on-site insulation tests of high-voltage systems like power and measuring transformers, circuit breakers, capacitors and isolators. With the add-on device *CP TD*, the *CPC 100* increases its range of possible applications into high-voltage measurements.

The internal switched mode power amplifier enables measuring at different frequencies without interferences with the mains frequency. Automatic test procedures reduce the testing time to a minimum. Test reports are generated automatically.

The *CP TD* comes with its own test card named **TanDelta** (Tangent Delta), which provides highly accurate measurements of the capacitance C_x and the dissipation factor $\tan\delta$ (DF) or power factor $\cos\phi$ (PF), respectively.

Both the dissipation factor and the power factor grant information about possible losses in the insulation material, which are increasing with age and water content. A change of C_x is a warning indicator for partial breakdowns between the layers of a bushing or a capacitor.

Additionally, the *CP TD* measures the following quantities:

- Actual, apparent and reactive power
- Quality factor QF
- Inductance
- Impedance, phase angle
- Test voltage & current

The *CP TD* works as an add-on device to the *CPC 100*. Do not connect the *CP TD* to any other device. Do not use the accessories for applications not indicated in this User Manual.

Note: Any other use of the *CP TD* but the one mentioned above is considered improper use, and will invalidate all customer warranty claims and exempt the manufacturer from any liability to recourse

Setup of devices with and without trolley

With trolley

The equipment trolley holds the *CPC 100*, *CP TD* and all required cables. The trolley is equipped with a grounding bar with three knurled screws to ensure a solid grounding to equipotential ground of all devices.

- ▶ Properly connect the *CPC 100* and *CP TD* grounding terminals to the trolley's ground bar. Connect the ground bar to earth.

Without trolley

- ▶ Place the *CPC 100* and *CP TD* on their transport cases and connect them with the long type data cable *CPC 100* ⇔ *CP TD* (3 m) and the long-type booster cable *CPC 100* ⇔ *CP TD* (3 m).
- ▶ Ground each device separately using a 6 m grounding cable of at least 6 mm².

CP TD connected to a power transformer

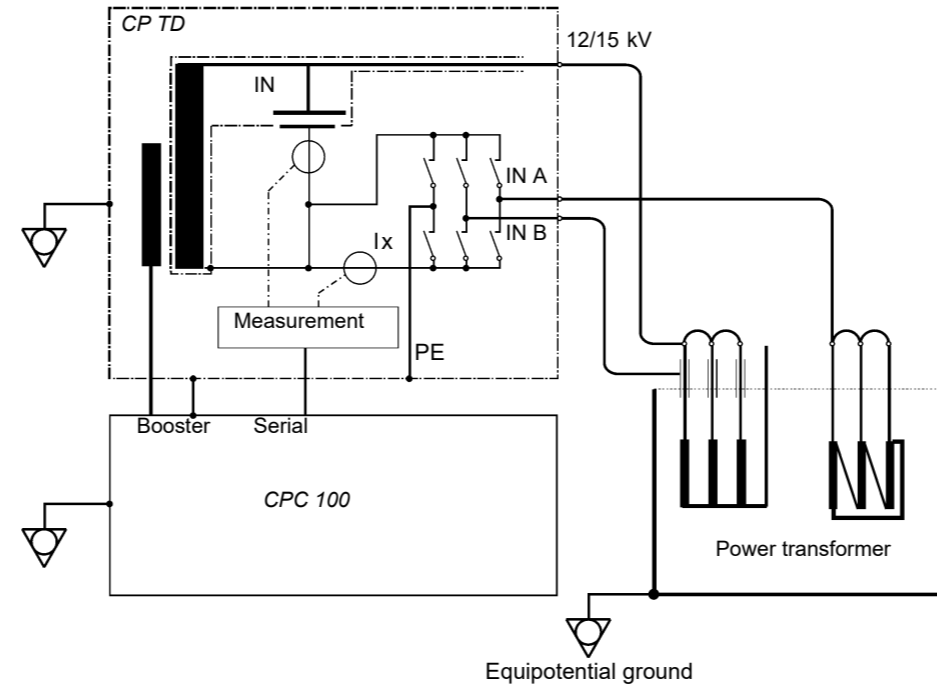

Putting the CP TD into operation

DANGER

Death or severe injury caused by high voltage or current



- ▶ As the first step, before you set a *CPC 100* / *CP TD* measurement setup into operation, link the *CPC 100*, *CP TD* and, if applicable, the equipment trolley with a min. 6 mm² grounding cable as displayed on page CP TD1-2.
- ▶ Never use the *CPC 100* / *CP TD* measurement setup without a solid connection to ground.

1. Switch off the *CPC 100* at the main power switch.
2. **With trolley:**
Properly connect the *CPC 100* and *CP TD* grounding terminals to the trolley's ground bar. Connect the ground bar to earth.
Without trolley:
Properly connect the *CPC 100* and *CP TD* grounding terminals to earth.
▶ Only use cables of at least 6 mm² cross-section.
3. Connect the *CP TD*'s **BOOSTER IN** to the *CPC 100*'s **EXT. BOOSTER** using the supplied booster cable.
4. Connect the *CP TD*'s **SERIAL** to the *CPC 100*'s **SERIAL** using the supplied data cable. This cable also provides the power supply for the *CP TD*.

Putting the CP TD into operation

- Pull out the measuring cables from the cable drum and connect the test object to the CP TD's measuring inputs **IN A** and **IN B**.

DANGER



Death or severe injury caused by high voltage or current

- ▶ Do not remove *any* cables from the CP TD or the test object during a test.
 - ▶ At all times during a test, both low-voltage measuring cables must be well attached and tightly connected to the CP TD's measuring inputs IN A and IN B.
 - ▶ Make sure to insert the cables marked red and blue into the corresponding measuring inputs: IN A = red, IN B = blue.
 - ▶ Tighten the plugs by turning them until you feel a stop.
- Pull out the high-voltage cables from the cable drum and connect the test object to the CP TD's high-voltage output.
 - Switch on the CPC 100.
 - Selecting the **TanDelta** test card from any of the CPC 100's **CT**, **VT**, **Transformer** or **Others** test card groups automatically turns on the CP TD. If no CP TD is connected to the CPC 100, an error message appears.
 - Set up your measurement in the **TanDelta** test card (see page CP TD1-4).
 - Press the CPC 100's I/O (test start / stop) push-button.

Application and test templates

For detailed information on the CP TD applications, refer to the User Manual delivered with the CP TD or available in pdf format on the CPC 100 Start Page.

Test templates

The test procedures for designated applications are controlled by templates available on the CPC 100 Toolsets shipped with your CP TD or on the CPC 100 Start Page.

Test templates are available for the following areas:

- Power transformers
- Instrument transformers
- Rotating machines
- Cables and transmission lines
- Grounding systems
- Others

TanDelta-PF test card - main page

The **TanDelta-PF** test card can be accessed from **CT**, **VT**, **Transformer** and **Others** test card groups.

Select "Assessment" to automatically assess the test, clear for no assessment. Enter the nominal values in the entry fields (here "Cref" and "DFref"; availability and naming depend on the measuring mode). These values serve as reference for the assessment. Their tolerance range can be set on the **Settings** page (see page CP TD1-5). A measurement is rated as 'OK' if **both** values are within their tolerance range. The assessment is displayed in the test point tables's column "?"

Note: While a test is running, new nominal values can already be entered.

Test voltage and frequency

Select for automatic measurement, clear for manual measurement. *)

Selecting enables the list boxes.

Selecting a measuring mode and pressing the handwheel displays an image that shows the according arrangement of the internal measurement switch-matrix. **)

TanDelta-PF test card - main page

“Auto test points” cleared = manual measurement: Applies the set test voltage and frequency to the CP TD’s output. When the measurement is finished, its results are displayed in the results table.

“Auto test points” selected = automatic measurement: Enables the output of a series of test points, e.g., combining a series of voltage values with one fixed frequency value creates a voltage ramp. Combining a series of frequency values with one fixed voltage value creates a frequency ramp. Furthermore, a combination of both is possible.

- ▶ Set a test voltage and frequency of your choice, and press **Add to Auto**. The values are entered into the list boxes.
- ▶ Set a second test voltage and/or frequency, and again press **Add to Auto**. The value(s) is/are appended to the list.
- ▶ Repeat this procedure as often as you need.

Note: You cannot enter the same value twice. Double entries are rejected. If you need identical test points for an increasing and a decreasing voltage ramp, set values very close to each other, e.g., 2000 V and 2001 V.

The CP TD then puts out the specified list of values as follows:

1. All voltages are issued in the exact order they were entered using the *first* frequency value of the list.
2. All voltages are issued once more in the exact order they were entered using the *second* frequency value of the list (if any).
3. ... and so forth.

Each combination is one individual measurement, and its result is displayed in the results table with an individual line.

To delete an entry from a list box, place the cursor on the value and press **Delete Value**. Do delete all values from both list boxes, place the cursor on "Auto test points (V, f)" and press **Delete List**.

During the measurement, the list boxes display the current output values.

Measuring modes and their according arrangements of the internal switch-matrix in the CP TD.

The switch-matrix determines what capacities are actually measured.

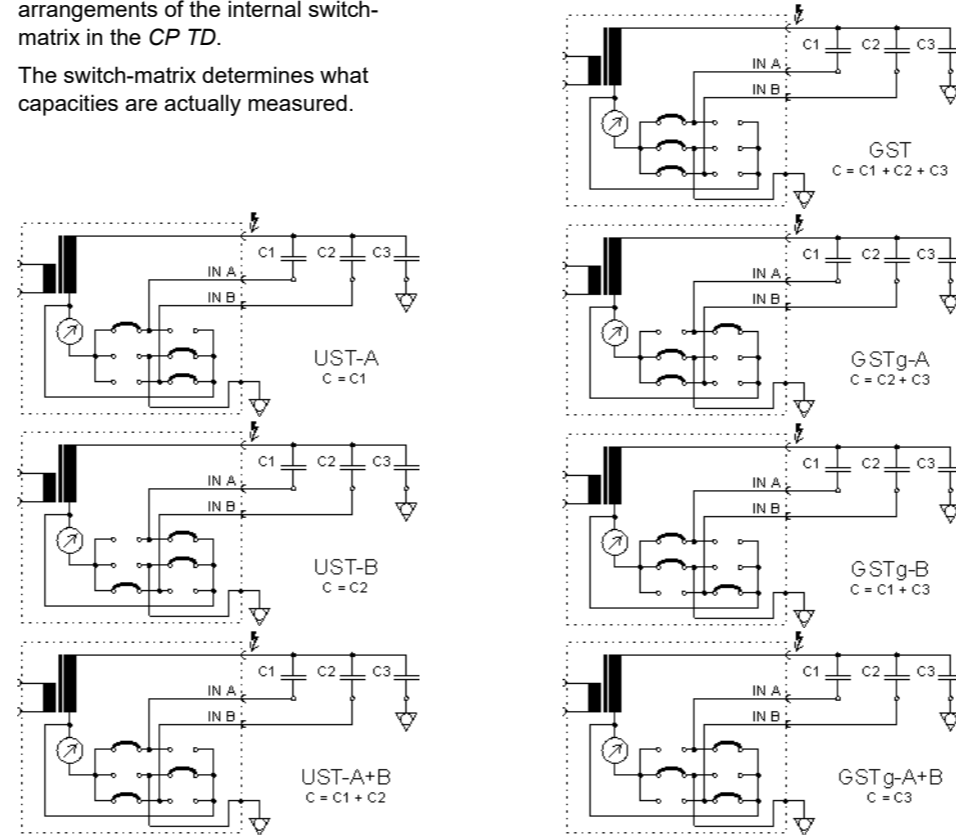

Compound measurement setting

Cp, DF (tan δ) = parallel capacitance & dissipation factor
 Cp, PF (cos φ) = parallel capacitance & power factor
 Cp, Ptest = parallel capacitance & power
 Cp, P@10kV = parallel capacitance & power; linearly interpolated to 10 kV test voltage
 Qtest, Stest = reactive & apparent power
 Z = impedance with phase angle
 Cp, Rp = parallel capacitance & parallel resistance
 Ls, Rs = serial inductance & serial resistance
 Cp, QF = parallel capacitance & quality factor
 Ls, QF = series inductance & quality factor

The averaging factor determines the number of measurements. A factor of 3 means: the CP TD carries out 3 measurements whose results are then averaged. The higher the factor, the more accurate the measurement but the longer the measuring time.

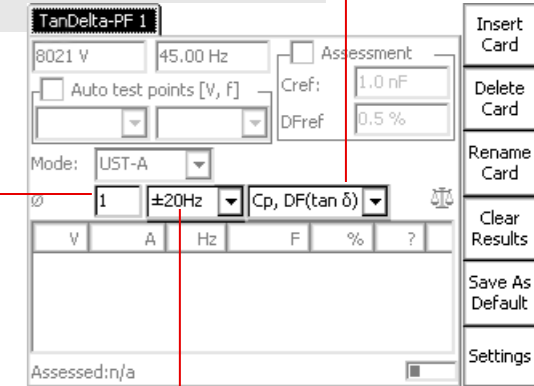

Filter bandwidth of measurement.

Note: If the test frequency equals the default frequency (as set at **Options | Device Setup**), the filter bandwidth is always ± 5 Hz, regardless of the set value. This even applies if the option "use default frequency of xx.xx Hz" is not specifically selected. ± 5 Hz means that interferences at frequencies with an offset of ≥ ± 5 Hz from the measuring frequency will not affect the results. The smaller the filter bandwidth, the longer the measuring time.

TanDelta-PF test card - settings page

Pressing the **Settings** button on the **TanDelta** main page opens the **Settings** page allowing you to set additional measurement options.

The *CP TD* leaves OMICRON electronics factory-calibrated. If a component needs to be exchanged by a spare part, the *CP TD* must be re-calibrated.

To re-calibrate, set the focus onto the test card tab designation **TanDelta** and press **Edit Calib** to enable the entry fields:

- Cx = correction factor for Cmeas (multiplier)
- DF/PF + = corrective value added to dissipation or power factor (can be + or -)

Enter your name and press **Update Calib** to complete the re-calibration.

If selected, the beeper sounds during the entire test. If cleared, the beeper sounds at the beginning and the end of the test only.

If selected, the *CPC 100* checks whether the shield of the high-voltage cable is connected. For some large inductive loads, the *CPC 100* can accidentally report shield check error even when the shield is connected. If this is the case, it makes sense to clear the check box.

At "Assessment Limits", set the tolerance of the main page's nominal values for the assessment. For the capacitance, the tolerance is entered in percent, for the dissipation factor it's a multiplier.

Note: Availability and naming of the entry fields depend on the measuring mode, e.g., DF and PF are the same entry field.

*) Selecting "Compensations" converts the actually measured dissipation or power factor to normalized values corresponding to an ambient temperature of 20 °C. In doing so, the values entered at "Compensations" represent the existing ambient condition.

- ▶ Enter oil temperature, ambient temperature (at bushing) and relative humidity first.
- ▶ Then place the cursor on "k".

The medium the measurement takes place in, oil or air, determines the k-factor.

- **ANSI C57.12**
The oil temperature is the determining medium for the k-factor.
- **Bushings**
The air temperature at the respective bushing is the determining medium for the k-factor. **Bushings** provides three bushing types to select from: RBP (**R**esin **B**onded **P**aper), RIP (**R**esin **I**mpregnated **P**aper) and OIP (**O**il **I**mpregnated **P**aper). The k-factor changes accordingly.

Select if you use an external CT.
The entered ratio is used to calculate the measured current accordingly.
Note: "Use ext. CT" can only be selected if there are no measurement results yet.

Returns to **TanDelta's** main page

CP TD high-voltage source

**) In addition to the Dissipation Factor (TanDelta)/Power Factor test, the *CP TD* can also be used as a high-voltage source for measuring, for example, partial discharge or conducting high-voltage tests on rotating machines.

To compensate capacitive currents, a parallel resonance circuit can be set up.

The compensation using the *CP CR* (*CP CR500* or *CP CR600*) compensation reactor is realized in two different ways: First, by parallel circuiting the compensation reactors to measure as close as possible to the resonance frequency when measuring with nominal frequency is required. Second, by setting the frequency to measure at exactly the resonance frequency. The longest output duration is achieved with testing at resonance frequency, in most cases accomplished by a combination of both procedures.

The **CP TD High-Voltage Source** test card can be used both for manual or fully automatic testing by toggling defined ramps and sequences. The test card is also helpful in setting up the optimum test configuration to achieve the best possible test duration.

For more information on typical test procedure refer to the following user manuals:

- CP TD1 User Manual and CP CR500 User Manual
- CP TD12/15 User Manual and CP CR600 User Manual

Note: The *CP CR500* can only be used with the *CP TD1*, while the *CP CR600* can only be used with the *CP TD12* or *CP TD15*.

CP TD high-voltage source

Define automatic test cycle

Set maximum voltage

Show wiring configuration (test setup)

Activate search of resonance frequency

Activate the test to determine the test capacitance

Set test voltage

Set test frequency

Activate configuration of test setup with the CP CR

Set or show test capacitance

Select or show compensation inductance

Show the sequence number (only in automatic mode)

Measured output voltage

Watt losses of the test setup (test object and inductors)

Phase angle between output voltage and output current

Output current of the CP TD

Time of the test. The time starts again from zero if **Keep Result** is pressed.

Quick 1 TD1-HW-Source 1

V test: 5000.0 V V max: 12000.0 V

f test: 60.00 Hz Search f0... Wiring...

Test cycle... t on ~ 13 min

CR500

C: 885.17 nF Check C...

L comp.: 8.000 H

#	V	A	°	W	Time

Assessed: n/a

Enter

Back to Top

Test settings

Show minimum inductance possible with available CP CR

Show maximum inductance possible with available CP CR

Set available CP CR

Show calculated inductance for resonance frequency with f test and capacitance set in main page

Select or show compensation inductance combinations possible with available CP CR

Show configuration for selected L comp.

Test information

Set test frequency

Shows resonance frequency with selected L comp. and capacitance set in main page

Quick 1 TD1-HW-Source 1

CP CR500 available

L1 40H, L2 40H: 2 x

L1 80H, L2 40H: 0 x

L1 80H, L2 80H: 2 x

L min = 6.6667 H

L max = 80.000 H

L calc. = 7.948974 H

f test: 60.00 Hz

L comp.: 8.000 H

f0 comp. = 59.81 Hz

CP CR500 wiring for L comp.

3 x 40H 4 x 80H C 885.17 nF

OK

Enter

Back to Top

CP CU1

CPC 100 User Manual – CP CU1

Safety instructions

The CP CU1's outputs and the connected cables carry life-hazardous voltage or current.

- ▶ Always obey the five safety rules and follow the detailed safety instructions below.

Note: The safety instructions relevant to the CPC 100 and its accessories (refer to page Preface-1) also apply to the CP CU1. This section lists safety instructions that exclusively apply to the CP CU1.

General

- ▶ Before operating the CP CU1, read the CP CU1 User Manual carefully and observe the safety rules and instructions therein.
- ▶ Before handling the CP CU1 or CPC 100 in any way, connect them with a solid connection of at least 6 mm² cross-section to ground. Ground the CP CU1 as close as possible to the CPC 100.
- ▶ Use the CP GB1 grounding box to connect the CP CU1 to overhead lines and power cables. For detailed information, see the application-specific "Safety Instructions for Connecting CP CU1 to Power Lines" in the CP CU1 User Manual.
- ▶ When using the CP GB1, ground it near the place where the connection to the test object is made. Make sure that the grounding stud is in good condition, clean and free of oxidation.
- ▶ Make sure that all studs and cables of the CP GB1 are screwed tight.
- ▶ Make sure that the test object's terminals to be connected to the CP CU1 do not carry any voltage potential. During a test, the only power source for a test object may be the CP CU1 (powered by the CPC 100). The only exception are measurements on overhead lines as described in "Applications" in the CP CU1 User Manual.
- ▶ Use the CP CU1, CP GB1 and their accessories only in a technically sound condition and when its use is in accordance with the regulations. In particular, avoid disruptions that could in turn affect safety.

Operating the measurement setup

- ▶ When using the CP GB1, ground it near the place where the connection to the test object is made. Make sure that the grounding stud is in good condition, clean and free of oxidation.
- ▶ Life threatening voltages up to 600 V can appear on all CP GB1 contacts and on all clamps and cables connected to the CP CU1 during the test. Keep safe distance from them.
- ▶ Before handling the CP CU1 or CP GB1 in any way (even before setting the current range switch), make sure that the device under test (e.g. overhead lines or power cables) are well grounded (e.g. by closing the grounding switch) near the measurement setup.
- ▶ Ensure that the short-circuit bar is always plugged in the CP CU1 I AC output whenever the output is not connected to the I AC input of the CPC 100.
- ▶ Connect the CP CU1 I AC output exclusively to the I AC input of the CPC 100.
- ▶ Before connecting the CP CU1 with the CPC 100, turn off the CPC 100 either by the POWER ON/OFF switch or the Emergency Stop button.
- ▶ Set the current range switch on the CP CU1 front panel only when the CPC 100 is turned off and the test object is grounded.
- ▶ In addition to the above safety rules follow the application-specific "Safety Instructions for Connecting CP CU1 to Power Lines" in the CP CU1 User Manual.
- ▶ The CP CU1 may be used only as described in "Applications" in the CP CU1 User Manual. Any other use is not in accordance with the regulations. The manufacturer and/or distributor is not liable for damage resulting from improper usage. The user alone assumes all responsibility and risk.

Block diagram

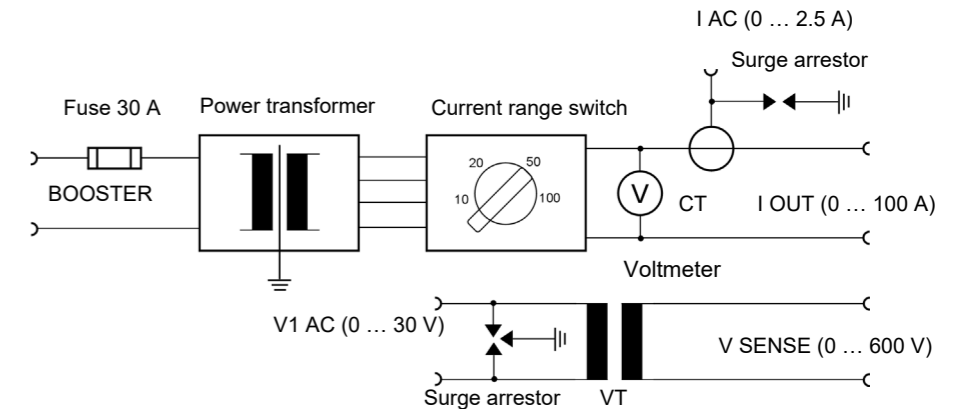

Measurement setup

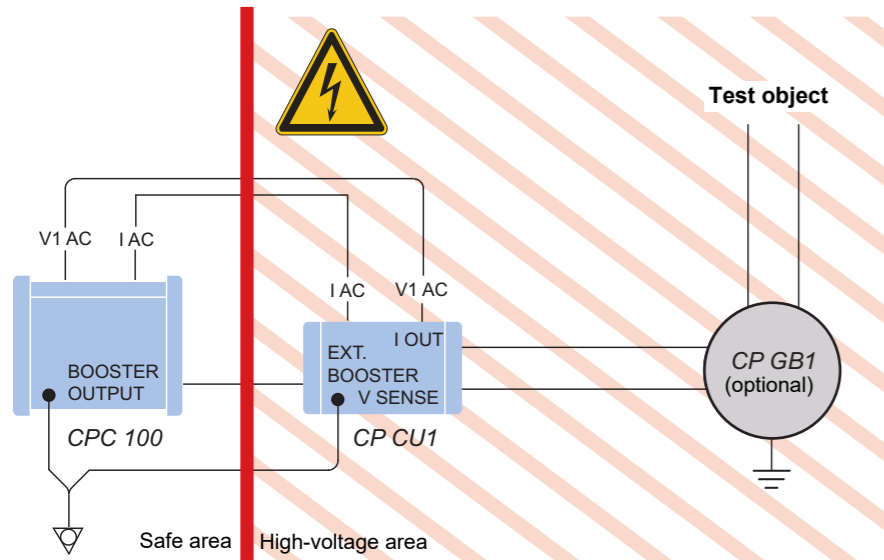

Configuring the CPC 100

The CPC 100 must be configured for the CP CU1. Follow the steps below to configure the CPC 100:

1. Press the **Options** view selector button to open the **Options** window.

Device Setup	Network	Display	Date/Time	Remote Mode
External booster: CU1				
Clamp & input transformer settings:				
IClamp:	V1 AC	0.10000 V/A		
CT:	I AC	100.0 A	2.5000 A	
VT:	V1 AC	600.0 V	30.0000 V	
<input type="checkbox"/> Disable ground check				
Default freq.:	50.00 Hz			
Auto save:	10 minutes			
				Reboot

2. In the **External booster** combo box, select **CU 1**.
The **CT** and **VT** settings are set according to the built-in current and voltage transformers automatically.
3. Set the current range of the CP CU1 using the current range switch (see page CP CU1-2) to the value configured by the CPC 100 software.

DANGER



Death or severe injury caused by high voltage or current

- ▶ Only set the current range switch on the CP CU1 front panel when the CPC 100 is turned off and the test object is connected to ground with closed grounding switch near the measurement setup.

Note: Current range settings on the test card and on the CP CU1 front panel must be the same.

Connecting the CPC 100 and CP CU1 to power lines

Safety Instructions

- ▶ Do not connect the measurement setup to overhead lines if there is a possibility of a thunderstorm over any part of the lines to be measured. A lightning discharge to the line under test can cause injury or possibly death of the operating staff.
- ▶ It is strongly recommended to take all parallel lines out of service before proceeding. Connecting the measurement setup to overhead lines with a life parallel system brings about high-voltage hazards.
- ▶ While the grounding switch at the near end of the power line is open, the area around the CP GB1 in the range of 5 m/15 ft and around the CP CU1 in the range of 2 m/5 ft is a dangerous zone due to high-voltage and mechanical hazards. Do not enter the dangerous zone. Keep the grounding switch open for a time as short as possible.
- ▶ If you see or hear anything uncommon in the test equipment, e.g. noise of electrical discharge or lightening of surge arrestors, close the grounding switch before touching the measurement setup.

Connecting the CPC 100 and CP CU1 to power lines

1st Criterion

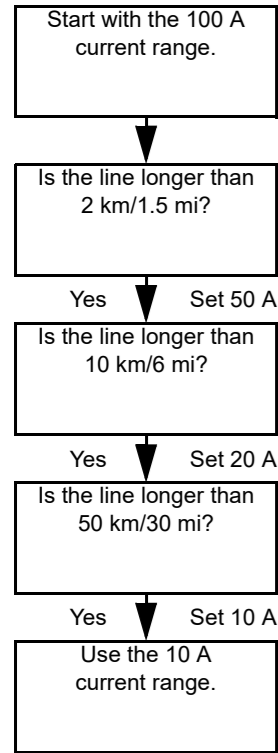

Connect a grounding set in parallel to the closed grounding switch to each phase. Connect it first to the ground and then to the line. Open the grounding switch and measure the currents in all three grounding sets. Use the highest measured value of $I_{1,2,3}$ in the following formula. Close the grounding switch after the measurement is done.

2nd Criterion

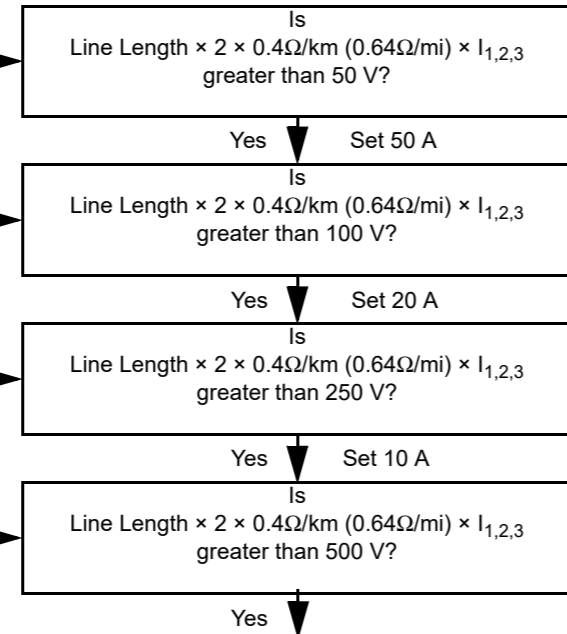

Stop! The measurement cannot be performed on this line.
Try to take parallel lines out of service or to reduce the current flow on the parallel systems.

Close the grounding switch, disconnect the grounding set first from the line and then from the ground. Connect the grounding set to the CP GB1 and then to the line. Make the connections to the CP CU1 and CPC 100 according to the figures on the following pages. Switch the CP CU1 to the 10 A current rate. Open the grounding switch and read the display value of the CP CU1. Stay out of the dangerous zone while doing this. Close the grounding switch afterwards.

3rd Criterion

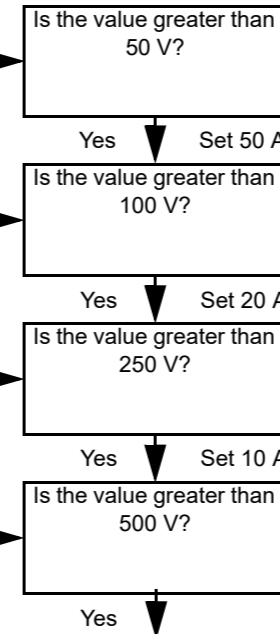

Start the measurement according to the application description on one of the following pages. Try to determine the maximum possible current at 20 Hz above and below the mains frequency.

4th Criterion

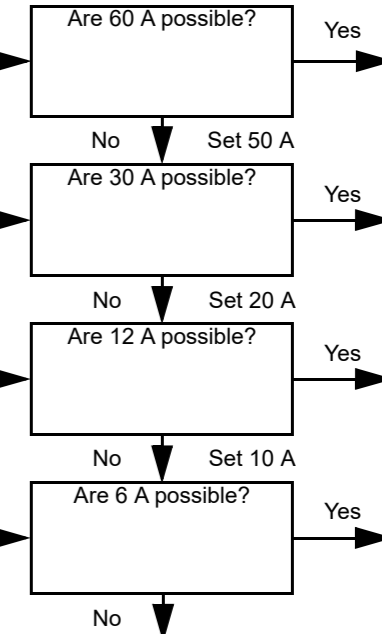

Set a lower required current in the CPC 100's 10 A test card. Inject at least 1 A to get reliable results.

Accurate measurements can be performed

Line impedance test card

Set-Up/Guidance

The **Line impedance** test card provides a guided workflow for testing of overhead transmission lines and power cables.

- Refer to the CP CU1 User Manual for detailed information on safety and the individual steps/criteria.

1. Step: Select the asset type:
3 phases
3 phases, coupled (mutual coupling)
2 phases
1 phase

2. Step – Line length: Enter the length of the line to be measured.

3. Step – Induced current: Enter the induced current of each of the phases for the line to be grounded on both ends.

4. Step – Open line V act.: Enter the open-line voltage measured when connecting the CP CU1 to a power line.

The recommended current range for the CPC 100 is calculated and provided in a new sub-window. If the measurement is not possible, an error message is displayed.

After you have closed the **Guidance** window by pressing **Ok**, the main page is displayed.

The max. test current corresponds to the proposed current range on the CP CU1.

Measurement loops. The number of loops depends on the selection under **Step 1** in the **Set-Up** sub-window.

k factor values calculated from the line impedance measurement results. k factor results are shown as soon as enough data is available and get more precise with every measurement loop concluded.

Click for frequency sweep settings.

Range indicator

LineImp 1

Itest: 12.50 A [20A] Test cycle ...

Impedance	R	X	Z	ϕ
A-B	n/a	n/a	n/a	n/a
B-C	n/a	n/a	n/a	n/a
C-A	n/a	n/a	n/a	n/a
A-G	n/a	n/a	n/a	n/a
B-G	n/a	n/a	n/a	n/a
C-G	n/a	n/a	n/a	n/a

k_L: n/a k_L phase: n/a
 k_R: n/a k_X: n/a
 k_D: n/a k_D phase: n/a

Tap to show the results in more detail (in graph or table view).

Applications and test templates

The following application examples show the typical usage of the CP CU1. The test procedures running on the measurement setup are controlled by templates available on the CPC 100 Start Page.

For detailed information on the CP CU1 applications, refer to the CP CU1 User Manual delivered with the CP CU1 or available in pdf format on the CPC 100 Start Page.

Line impedance measurement

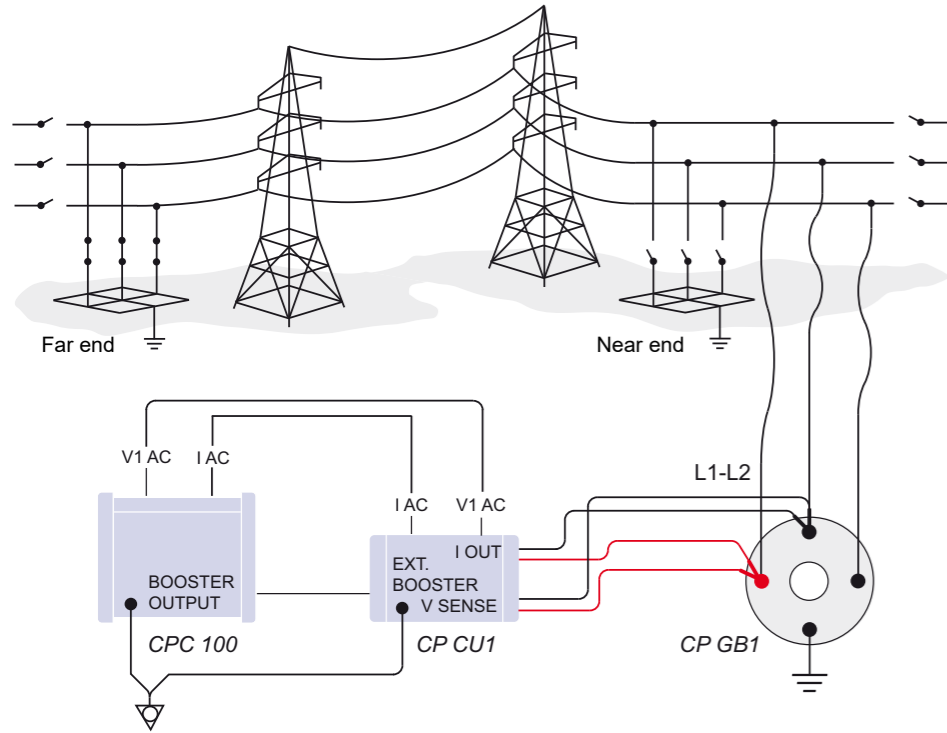

There are seven different measurement loops: L1-L2 (shown here), L1-L3, L2-L3, L1-E, L2-E, L3-E and L1,2,3 in parallel to earth (similar to the next figure).

Ground impedance measurement

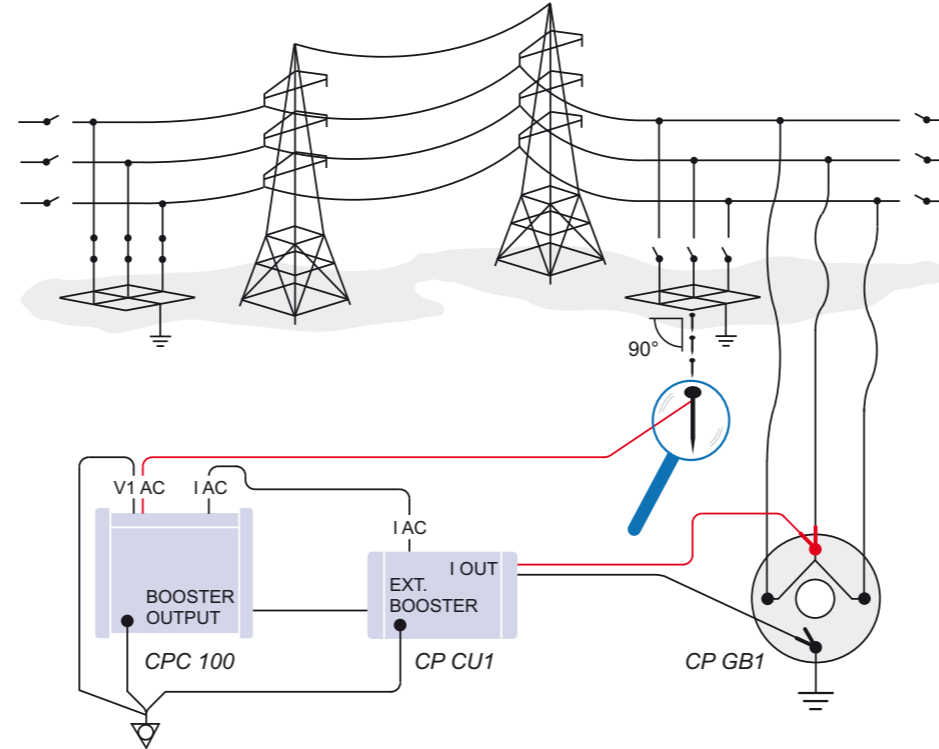

Measurement of coupling into signal cables

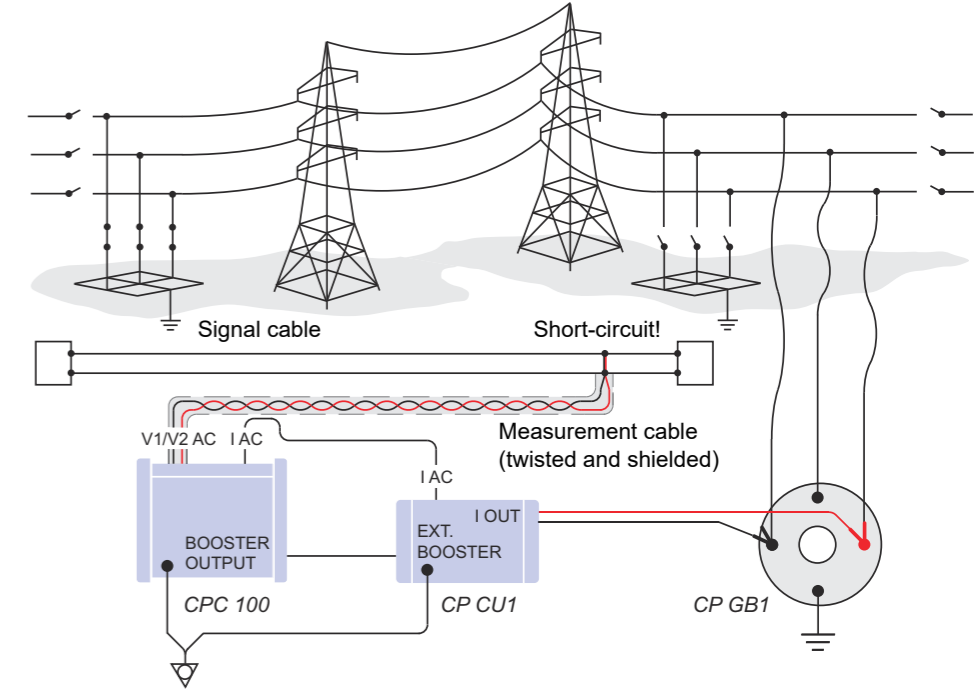

There are four measurements with different connections. For detailed information, refer to the template or the CP CU1 User Manual.

Step and touch voltage measurement

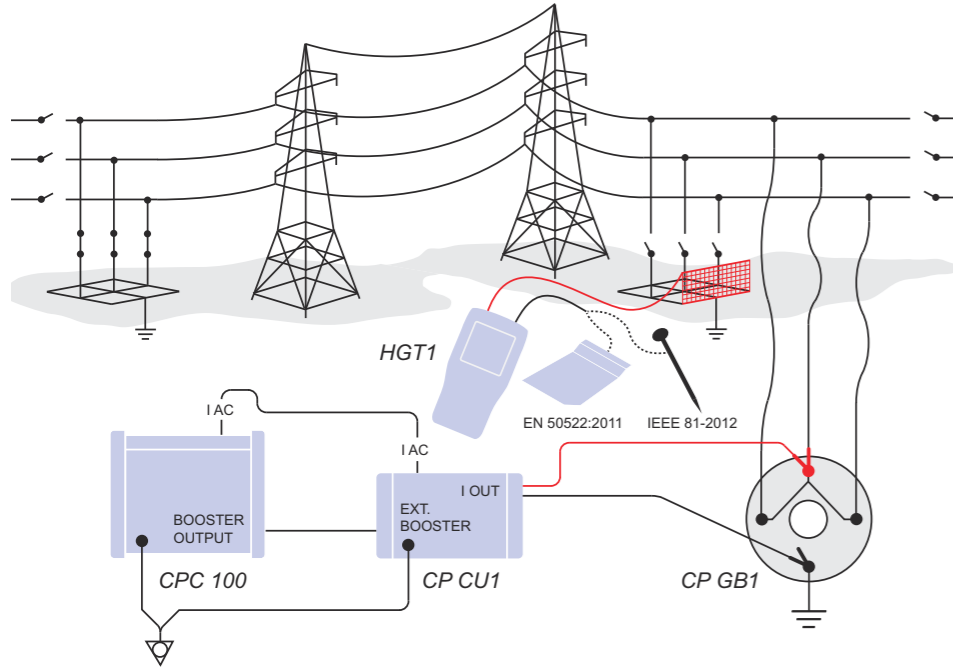

For step and touch voltage measurements using the *HGT1* FFT voltmeter, refer to the *HGT1* User Manual.

CP SB1

CPC 100 User Manual – CP SB1

Safety instructions

The *CP SB1*'s outputs and the connected cables carry life-hazardous voltage or current.

- ▶ Always obey the five safety rules and follow the detailed safety instructions below.

Note: The safety instructions relevant to the *CPC 100* and its accessories (refer to page Preface-1) also apply to the *CP SB1*. This section lists safety instructions that exclusively apply to the *CP SB1*.

General

- ▶ Position the *CP SB1* in the high-voltage area.
- ▶ Before connecting or disconnecting test objects and/or cables, turn off the *CPC 100* by either the POWER ON/OFF switch or the Emergency Stop button. Never connect or disconnect a test object while the outputs are active.
- ▶ Even if you switched off the *CPC 100*, wait until the red I/O status light is fully extinguished. As long as this status light is lit, there is still voltage and/or current potential on one or more of the outputs.
- ▶ When measuring the ratio of power transformers make sure that the test voltage is connected to the corresponding high-voltage winding, and the voltage of the low-voltage winding is the one that is measured. Accidentally mixing up the windings can generate life-threatening voltages within the transformer.
For example: feeding a voltage of 300 V to the low-voltage winding of a power transformer that has a ratio of 400000 V : 30000 V, induces a voltage of 4000 V in the transformer's primary winding.
- ▶ Do not operate the *CP SB1* under ambient conditions that exceed the temperature and humidity limits listed in "Technical Data".
- ▶ If the *CP SB1* or any add-on device or accessory does not seem to function properly, do not use it anymore. If in doubt, call the OMICRON electronics hotline.
- ▶ Before handling the *CP SB1* or *CPC 100* in any way, connect them with a solid connection of at least 6 mm² cross-section to equipotential ground. Ground the *CP SB1* as close as possible to the *CPC 100*.

- ▶ For the connection between the *CPC 100* and *CP SB1* only use the specially manufactured cables supplied by OMICRON electronics.

DC output to test objects with a high inductance

When using the DC Output to test power transformers with a high inductance, observe the following safety instructions:

- ▶ Use the **TRTapCheck** (tap changer winding resistance and on-load tap changer interruption check) test card only.
- ▶ As long as the *CPC 100* software shows the on-screen message "Switch off in progress", NEVER connect or disconnect test objects and/or cables.
- ▶ The message "Switch off in progress" notifies you that, while the *CPC 100* is deactivating, the connected external inductance (this means the test object) still "feeds" voltage potential back into the **6A DC** output.
- ▶ The existence of this voltage potential at the **6A DC** output is also indicated by a lit LED - even if the *CPC 100* is switched off.
- ▶ If a test object with a high inductance was connected to the *CPC 100*, short-out the test object additionally before disconnecting any cables.

Product description - designated use

The *CP SB1* is a transformer switch box designated for automatically measuring the ratio and winding resistance, and testing the tap changer of three-phase power transformers. It is an accessory to the *CPC 100*. Automatic control of the On-Load Tap Changer (OLTC) is included. Testing of power transformers over all taps and all phases is fully automated. Therefore, no rewiring is required. The *CP SB1* is controlled from the *CPC 100* via its serial interface. The results are recorded in the *CPC 100* with the ratio and tap changer test cards, and can be analyzed with the computer tool set (*CPC 100 Excel File Loader*).

Functional components of the CP SB1

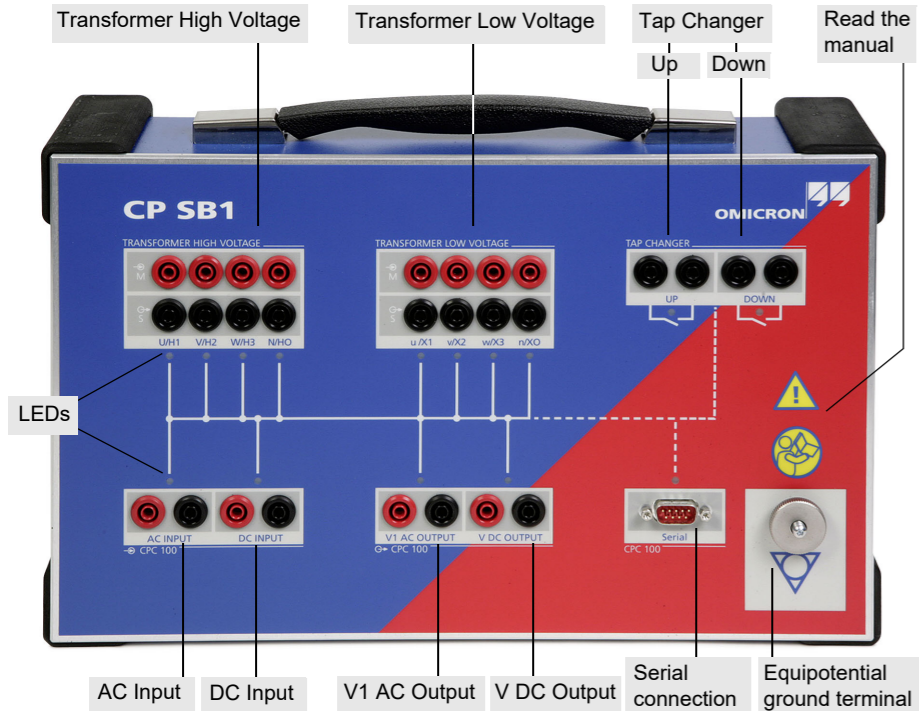

The front panel of the CP SB1 provides the following functional components:

- Transformer High Voltage:
 - Outputs (Source) for the injection of current or voltage on the individual phases of the transformer
 - Inputs (Measure) for the voltage measurement

Note: The inputs and outputs of the respective connections (U/H1, V/H2, W/H3, N/H0) are connected to the transformer using Kelvin clamps.
- Transformer Low Voltage:
 - Outputs (Source) for the injection of current or voltage on the individual phases of the transformer
 - Inputs (Measure) for the voltage measurement

Note: The inputs and outputs of the respective connections (u/X1, v/x2, w/x3, n/X0) are connected to the transformer using Kelvin clamps.
- Tap Changer: Two potential-free contacts for switching the tap changer
- AC input for connection to the **2KV AC** output of the CPC 100
- DC input for connection to the **6A DC** output and **I AC/DC** input of the CPC 100
- AC output for connection to the **V1 AC** input of the CPC 100
- DC output for connection to the **V DC** input of the CPC 100
- Serial interface for the CPC 100 (**TRRatio** and **TRTapCheck** test cards) to control the CP SB1
- Equipotential ground terminal for grounding the CP SB1 close to the position of the operating staff

Connecting the CPC 100 and CP SB1 to power transformers

DANGER

Death or severe injury caused by high voltage or current



- ▶ Position the CP SB1 in the high-voltage area and do not enter this area during the entire measurement.
- ▶ Connect the CPC 100 and CP SB1 using the delivered grounding cable.
- ▶ Connect the grounding cable of the CP SB1 at a safe grounding point at the transformer.
- ▶ Do not operate the test equipment without safe connection to ground.
- ▶ Make sure that all high-voltage connections of the transformer are removed.
- ▶ Make sure that all terminals of the transformer are connected to ground.

- ▶ Switch off the power supply of the tap changer.
- ▶ Connect the Kelvin clamps to the bushings.
- ▶ Connect the cables to the Kelvin clamps. Make sure that the cables show upwards and that each color is connected to a different phase.
- ▶ Connect the cables from the Kelvin clamps' voltage sense outputs to the CP SB1's transformer inputs. Observe the color code.
- ▶ Make sure to measure the voltage to ground at the terminals of the tap changer. If no voltage is measured, connect the flexible terminal adapters to the "up" and "down" terminals of the tap changer.
- ▶ Connect the cables ("up", "down") to the CP SB1.
- ▶ Connect the CP SB1 to the CPC 100 according to "Functional components of the CP SB1" on page CP SB1-2.
- ▶ Switch on the power supply of the tap changer.
- ▶ Remove all grounding connections of the terminals except one per winding. Use Neutral (N) for the grounding connection if accessible.
- ▶ Start the measurement according to page Transformer-1 and page Transformer-8.

Measurement setup

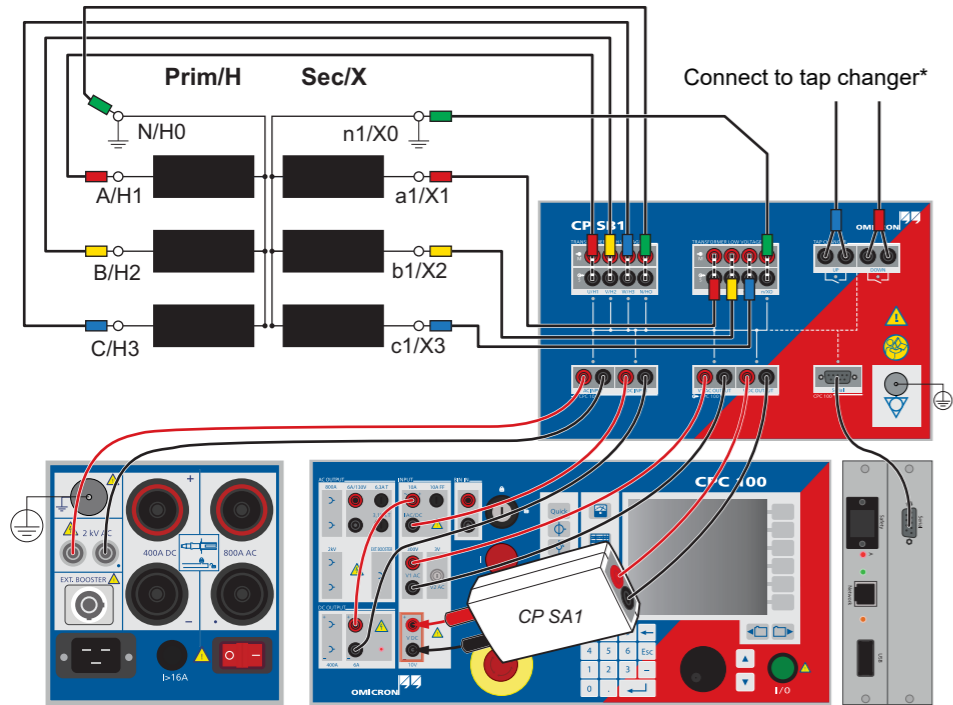

* Select auto-tap operation mode

CP CB2

CPC 100 User Manual – CP CB2

General

For test applications requiring up to 2000 A.

The output current of the CPC 100 can be increased up to 2000 A by means of an electronically controlled current booster. The CP CB2 can be connected close to the busbar using short high-current cables and to the CPC 100 with a long control cable.

- ▶ For test instructions refer to page Current Transformer-1.
- ▶ Select the CP CB2 as external booster on the **Device Setup** tab in the **Options** menu:

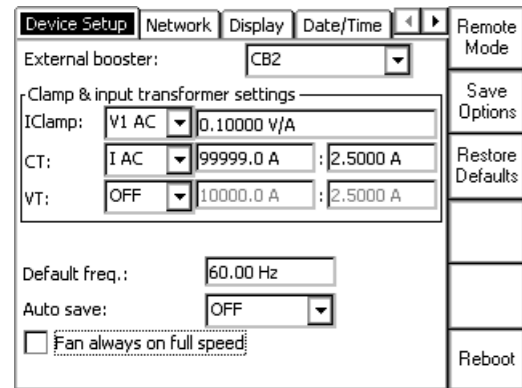

Note: If you select the CP CB2 as external booster on the **Device Setup** tab in the **Options** menu, it will be saved as default value for new test cards. However, it is also possible to select the external booster individually on the test cards. The settings for already inserted test cards will only be changed if no test results are available yet.

Operation modes of the CP CB2

2000 A mode:

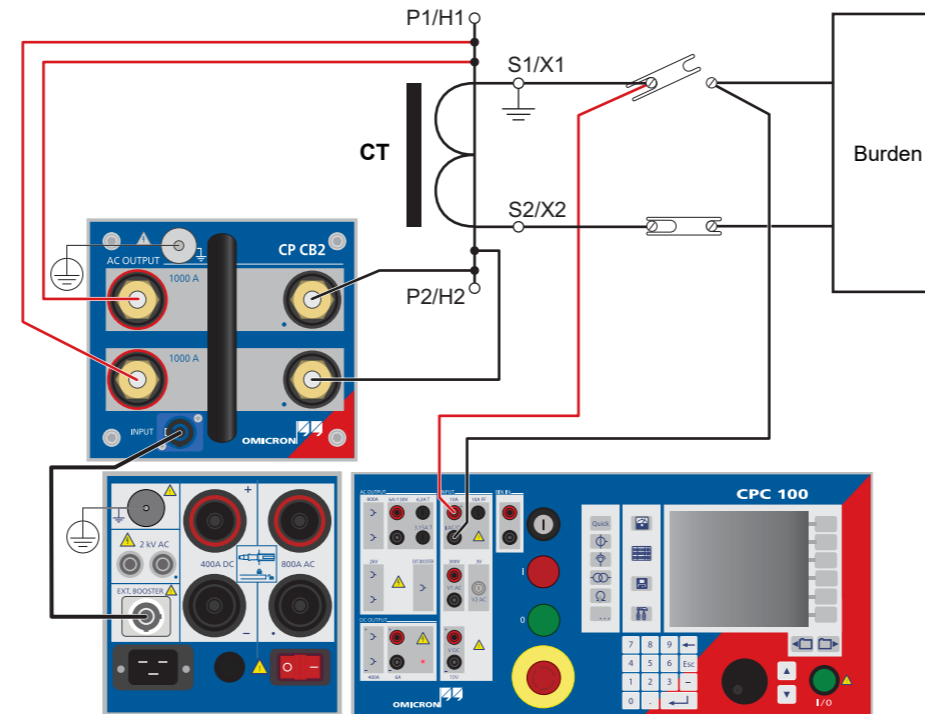

1000 A mode:

