

Megger[®]



STX 40

Portable Fault Location System

USER GUIDE

Issue: J (08/2024) - EN
Article number: 86883

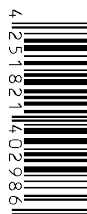

Consultation with Megger

The present system manual has been designed as an operating guide and for reference. It is meant to answer your questions and solve your problems in as fast and easy a way as possible. Please start with referring to this manual should any trouble occur.

In doing so, make use of the table of contents and read the relevant paragraph with great attention. Furthermore, check all terminals and connections of the instruments involved.

Should any question remain unanswered or should you need the help of an authorized service station, please contact:

Megger Limited
Archcliffe Road
Kent CT17 9EN
T: +44 1304 502100
F: +44 1304 207342
E: uksales@megger.com

Megger Germany GmbH (Baunach)
Dr.-Herbert-lann-Str. 6
D - 96148 Baunach
T: +49 9544 68 – 0
F: +49 9544 22 73
E: team.dach@megger.com

Megger Germany GmbH (Radeburg)
Röderau 41
D - 01471 Radeburg / Dresden
T: +49 35208 84 – 0
F: +49 35208 84 249
E: team.dach@megger.com

Megger USA
Valley Forge Corporate Centre
2621 Van Buren Avenue
Norristown, PA 19403 USA
T: +1 610 676 8500
F: +1 610 676 8610

© Megger

All rights reserved. No part of this handbook may be copied by photographic or other means unless Megger have before-hand declared their consent in writing. The information in this document is subject to change without notice and should not be construed as a commitment by Megger. Megger cannot be made liable for technical or printing errors or shortcomings of this handbook. Megger also disclaims all responsibility for damage resulting directly or indirectly from the delivery, supply, or use of this matter.

Terms of Warranty

Megger accept responsibility for a claim under warranty brought forward by a customer for a product sold by Megger under the terms stated below.

Megger warrant that at the time of delivery Megger products are free from manufacturing or material defects which might considerably reduce their value or usability. This warranty does not apply to faults in the software supplied. During the period of warranty, Megger agree to repair faulty parts or replace them with new parts or parts as new (with the same usability and life as new parts) according to their choice.

This warranty does not cover wear parts, lamps, fuses, batteries and accumulators.

Megger reject all further claims under warranty, in particular those from consequential damage. Each component and product replaced in accordance with this warranty becomes the property of Megger.

All warranty claims versus Megger are hereby limited to a period of 12 months from the date of delivery. Each component supplied by Megger within the context of warranty will also be covered by this warranty for the remaining period of time but for 90 days at least.

Each measure to remedy a claim under warranty shall exclusively be carried out by Megger or an authorized service station.

This warranty does not apply to any fault or damage caused by exposing a product to conditions not in accordance with this specification, by storing, transporting, or using it improperly, or having it serviced or installed by a workshop not authorized by Megger. All responsibility is disclaimed for damage due to wear, will of God, or connection to foreign components.

For damage resulting from a violation of their duty to repair or re-supply items, Megger can be made liable only in case of severe negligence or intention. Any liability for slight negligence is disclaimed.

Since some states do not allow the exclusion or limitation of an implied warranty or of consequential damage, the limitations of liability described above perhaps may not apply to you.

Contents

Consultation with Megger3

Terms of Warranty4

Contents5

1 Safety Instructions7

1.1 General Notes7

1.2 General Safety Instructions and Warnings.....8

2 Technical description10

2.1 System description10

2.2 Technical data12

2.3 Display and operating elements15

2.4 Connection elements.....16

2.5 Safety devices17

2.6 Operation in vehicle.....18

3 Commissioning19

3.1 Electrical connection20

3.1.1 Use of an external safety device (optional)24

3.2 Switch on25

3.3 High-voltage control26

4 Operation27

4.1 Screen layout27

4.2 Basics of control system.....29

4.3 Quick selection of operating modes – 31

4.4 On-line help – 31

4.5 Phase selection – 32

4.6 History database - 33

4.7 System settings - 36

4.7.1 Data menu - 38

4.7.2 Basic settings - 39

4.7.3 Administration menu -  (administration password required).....40









4.7.3.1 Updating the software - 41

4.7.3.2 User administration - 42

4.7.3.3 Connection Cable Calibration - 43

5 Performing measurements.....44

5.1 Good to know44

5.1.1	Propagation velocity	44
5.1.2	Pulse width	45
5.1.3	Typical TDR reflectograms	46
5.2	Standard functions	47
5.3	Systematics of cable fault location	51
5.4	Insulation test - Ω	52
5.5	DC voltage test / breakdown detection	53
5.6	Sheath test and sheath fault detection	54
5.6.1	Perform sheath test - 	55
5.6.1.1	Pinpointing a sheath fault - 	57
5.7	Pulse reflection measurement (TDR) - 	59
5.8	Pre-location of high-resistance cable faults - 	61
5.8.1	Arc reflection measurement (ARM) - 	61
5.8.2	Voltage decoupling (DECAY) - 	65
5.8.3	Current decoupling (ICE) - 	67
5.9	Burning - 	70
5.10	Surge pinpointing - 	71
6	Completing the work	73
7	Transportation, storage and care	74
8	Troubleshooting and maintenance	75



1 Safety Instructions

1.1 General Notes

Safety precautions This manual contains basic instructions for the commissioning and operation of the device / system. For this reason, it is important to ensure that the manual is always available to the authorised and trained operator. He needs to read the manual thoroughly. The manufacturer is not liable for damage to material or humans due to non-observance of the instructions and safety advices provided by this manual.

Locally applying regulations have to be observed!

Labelling of safety instructions The following signal words and symbols are used in this manual and on the product itself:

Signal word / symbol	Description
DANGER	Indicates a potential hazard which will result in death or serious injury if not avoided.
WARNING	Indicates a potential hazard which may result in death or serious injury if not avoided.
CAUTION	Indicates a potential hazard which may result in moderate or minor injury if not avoided.
NOTICE	Indicates a potential hazard which may result in material damage if not avoided.
	Serves to highlight warnings and safety instructions. As a warning label on the product it is used to draw attention to potential hazards which have to be avoided by reading the manual.
	Serves to highlight warnings and safety instructions that explicitly indicate the risk of an electric shock.
	Serves to highlight important information and useful tips on the operation of the device/system. Failure to observe may lead to unusable measurement results.

Working with products from Megger It is important to observe the generally applicable electrical regulations of the country in which the device will be installed and operated, as well as the current national accident prevention regulations and internal company directives (work, operating and safety regulations).

After working on the system, it must be voltage-free and secured against reconnection as well as having been discharged, earthed and short-circuited.

Use genuine accessories to ensure system safety and reliable operation. The use of other parts is not permitted and invalidates the warranty.

Operating staff The system may only be installed and operated by an authorised electrician. DIN VDE 0104 (EN 50191), DIN VDE 0105 (EN 50110) and the German accident prevention regulations (UVV) define an electrician as someone whose knowledge, experience and familiarity with the applicable regulations enables him to recognise potential hazards.

Anyone else must be kept away!

Declaration of Conformity (CE) The product meets the following security requirements of the European Council Directives:

- EMV Directive (2014/30/EC)
- Low Voltage Directive (2014/35/EC)
- RoHS Directive (2011/65/EU)

1.2 General Safety Instructions and Warnings

Intended application The operating safety is only guaranteed if the delivered system is used as intended (see page 10). Incorrect use may result in danger to the operator, to the system and the connected equipment.

The thresholds listed in the technical data may not be exceeded under any circumstances.

Five safety rules



The five safety rules must always be followed when working with HV (High Voltage):

1. De-energise
2. Protect against re-energising
3. Confirm absence of voltage
4. Earth and short-circuit
5. Cover up or bar-off neighbouring energised parts



Using cardiac pacemaker / defibrillator

Physical processes during operation of high voltage may endanger persons wearing a cardiac pacemaker or defibrillator when near these high voltage facilities.

	<p>Fire fighting in electrical installations</p> <ul style="list-style-type: none">• According to regulations, carbon dioxide (CO₂) is required to be used as extinguishing agent for fighting fire in electrical installations.• Carbon dioxide is electrically non conductive and does not leave residues. It is safe to be used in energized facilities as long as the minimum distances are maintained. A CO₂ fire extinguisher must be always available within electrical installations.• If, contrary to the regulations, any other extinguishing agent is used for fire fighting, this may lead to damage at the electrical installation. Megger disclaims any liability for consequential damage. Furthermore, when using a powder extinguisher near high-voltage installations, there is a danger that the operator of the fire extinguisher will get an electrical shock from a voltage arc-over (due to the powder dust created).• It is essential to observe the safety instruction on the extinguishing agent.• Applicable is DIN VDE 0132.
 WARNING	<p>Dangers when working with high voltage</p> <p>Working on high voltage systems and equipment – especially in non-stationary operation – requires particular care and safety-conscious action on the part of test personnel. VDE regulations 0104 on setting up and operating electrical test systems, as well as EN 50191 and national standards and regulations must be strictly adhered to.</p> <ul style="list-style-type: none">• The STX 40 generates a dangerous voltage of up to 40 kV during measurement operation. This is supplied to the test object via a high-voltage cable.• The test system may not be operated without supervision.• Never fail to use safety equipment or put it out of operation.• Operation requires minimum two people whereas the second person must be able to activate the emergency switch in case of danger.• To prevent dangerous charge accumulation, earth all metal parts in the vicinity of the high voltage equipment.

2 Technical description

2.1 System description

Functional description The fault location system STX 40 is a portable, multi-functional device suitable for outdoor use for testing and locating faults on low and medium voltage cables.



It comes with the following features:

- Dedicated DC test and breakdown detection up to 40 kV
- Dedicated Insulation test up to 20 kV
- Prelocation of faults with well-established HV methods such as arc reflection measurement (ARM), current decoupling (ICE), and voltage decoupling (DECAY)
- Conversion of faults by burning with up to 850 mA
- Pinpointing of faults by surging/thumping with up to 2.000 J in multiple voltage ranges
- Sheath test with up to 20 kV with automatic breakdown detection
- Pinpointing the location of sheath faults with up to 20 kV using the voltage gradient method (step voltage method)

The STX 40 has an integrated time domain reflectometer, which eliminates the time-consuming cabling work before locating faults and ensures a perfectly coordinated temporal sequence of surge decoupling and pulse reflection measurement.

With its easy-to-read 10 inch display, the reflectometer simultaneously forms the central control unit of the system and enables intuitive and fast selection and configuration of the operating modes.

A well-established integrated safety system ensures the safety of the operator by continuously monitoring the earthing and temperature conditions during operation.

Scope of delivery The scope of delivery includes the following components:

Component	Item number
Fault location system STX 40	1011497 (without 4 kV voltage range) 1013011 (with 4 kV voltage range)
Mains supply cable	Varies by region
Earthing cable drum with earthing cable, 25 m	2013151
Separate earthing cable (5 m) for connection between earthing drum and system	2013149
Reference earth wire (red, 5 m) for fault voltage (FU) monitoring + metal earth rod and hammer	820003013 (earth wire) 892479915 (earth rod) 892517507 (hammer)
High-voltage connecting cable, 25 m on drum	2012308
Various connectors and terminals	---
Device key	2012515
Manual	86883

Check contents Check the contents of the package for completeness and visible damage right after receipt. In the case of visible damage, the device must under no circumstances be taken into operation. If something is missing or damaged, please contact your local sales representative.

Optional accessories If the following optional accessories are not included in the scope of delivery, they can be ordered through Sales:

Accessory	Description	Item number
External safety device	For indicating the operating state and for emergency shutdown or locking the high voltage (in accordance with EN 50191)	2012574

2.2 Technical data

The STX 40 is defined by the following parameters:

Parameter	Value
Insulation test <ul style="list-style-type: none"> • Measuring voltage • Measuring range 	1 ... 20.000 V (adjustable in steps of 0.1 kV) 100 ... 650 MΩ
DC test <ul style="list-style-type: none"> • Output voltage • Leakage current measurement 	1 ... 40 kV ±1.5% (adjustable in steps of 0.1 kV) 0 ... 1A ±2%
TDR module <ul style="list-style-type: none"> • Measuring range (at v/2 = 80 m/μs) • Pulse width • Pulse amplitude (bipolar) • Resolution • Accuracy • Timebase accuracy • Data rate • Propagation velocity • Dynamic range • Output impedance • Distance-dependant de-attenuation (ProRange) • Number of traces 	20 m ... 320 km 20 ns ... 10 μs 100 V 0.1 m at v/2 = 80 m/μs 0.1% <50 ppm 533 MHz As V/2 or NVP value 10 ... 149.9 m/μs or 33 ... 492 ft/μs 115 dB 50 Ω +40 dB, adjustable Up to 6 traces simultaneously (e.g. for phase comparison)
Surging <ul style="list-style-type: none"> • Surge levels¹ • Surge rate 	0 ... 8 / 16 / 32 kV with 2,000 J 0 ... 4 kV with 1100 J (optional) Every 3 seconds at 2000 J at 32 kV Adjustable between 3 ... 10 seconds or single pulse

¹ If the system is connected to 120 VAC input voltage, surge power is limited to 1,600 W (as per ANSI/NEMA 5)

Parameter	Value
Fault pre-location methods <ul style="list-style-type: none"> • Inductive ARM Multishot • ICE • DECAY 	<p>Reflection measurement while the arc caused by a fault flash-over at the fault position is still burning. A total of 32 fault traces are recorded per measurement.</p> <p>Current decoupling from a traveling wave caused by a fault breakdown</p> <p>Voltage decoupling from a traveling wave caused by a fault breakdown</p>
Burning	<p>Max. 850 mA in 5 kV range</p> <p>Max. 400 mA in 10 kV range</p> <p>Max. 200 mA in 20 kV range</p> <p>Max. 100 mA in 40 kV range</p>
Sheath test <ul style="list-style-type: none"> • Output voltage • Leakage current measurement 	<p>1 ... 20 kV $\pm 1.5\%$ (adjustable in steps of 0.1 kV)</p> <p>0 ... 1 A $\pm 2\%$</p>
Sheath fault pinpointing <ul style="list-style-type: none"> • Output voltage • Pulse ratio 	<p>1 ... 20 kV $\pm 1.5\%$ (adjustable in steps of 0.1 kV)</p> <p>0.5:1, 1:3, 1:4, 1:6</p>
Safety	<ul style="list-style-type: none"> • FΩ protection device • FU protection device • Temperature monitoring • Device key for high voltage locking
Input voltage range	110 ... 230 VAC $\pm 10\%$, 50 / 60 Hz
Power consumption	2.5 kVA
Display	10.1" colour TFT WXGA 1280x800, capacitive touch screen, 1000 cd/m ² , LED-backlight
Memory	4 GB mSATA for program and data
Interfaces	1 x USB 2.0
Operating temperature	-20 °C ... +55 °C
Storage temperature	-40 °C ... +70 °C
Relative humidity	93% at 30 °C (non-condensing)
Dimensions (W x H x D)	74cm x 103cm x 65cm (with folded in handle)
Weight	124 kg (with 4 kV voltage range) 119 kg (without 4 kV voltage range)

Parameter	Value
Protection class (in accordance with IEC 61140 (DIN VDE 0140-1))	I
Ingress protection rating (in accordance with IEC 60529 (DIN VDE 0470-1))	IP43

2.3 Display and operating elements

The following operating and display elements are located on the front panel of the STX 40:

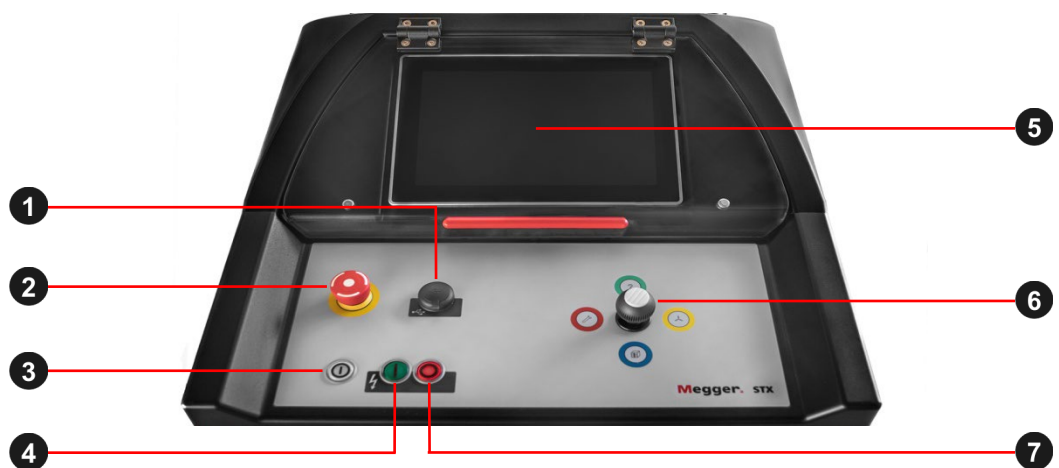

Element	Description
1	USB port
2	Emergency stop switch
3	On/off button
4	"HV ON" button
5	Display
6	Rotary encoder with tilt function
7	"HV OFF" button

2.4 Connection elements

The following connection and fuse elements are located on the back of the STX 40:

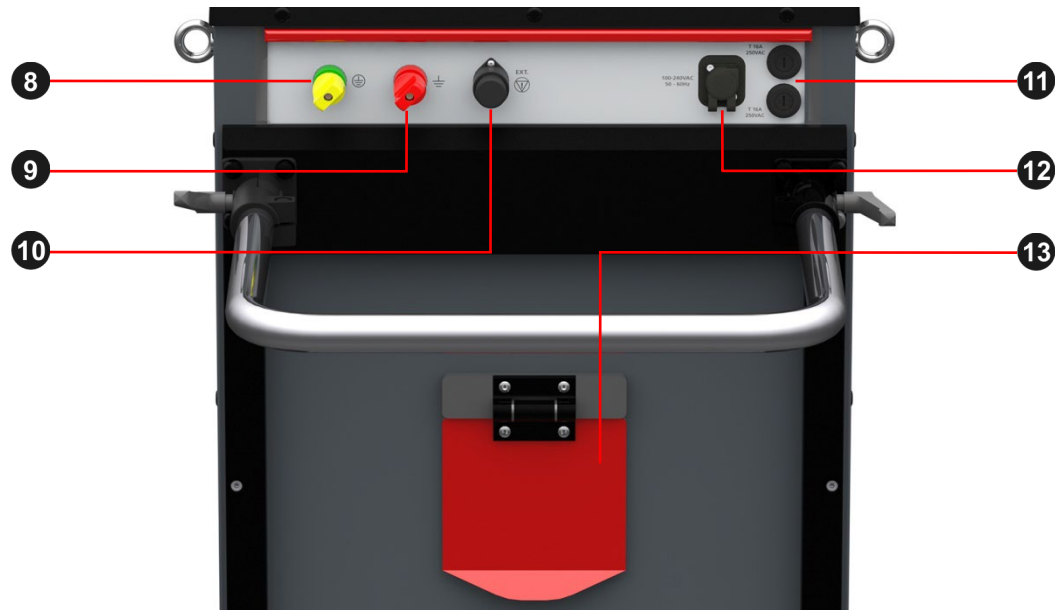

Element	Description
8	Protective earth connection
9	Reference earth connection for FU monitoring
10	Socket for connecting the device key or the external safety device
11	Fuses (2 x T16 A)
12	Mains socket
13	HV output

2.5 Safety devices

FΩ and FU monitoring In order to ensure sufficient earthing, the resistance between the operating and protective earth is continuously monitored during operation (FΩ monitoring). This must not exceed 6 Ω.

In parallel, the FU safety device checks that the voltage difference between the device and earth (reference earth) does not exceed 33 VDC or 40 VDC in order to protect the operator from step voltage potentials.

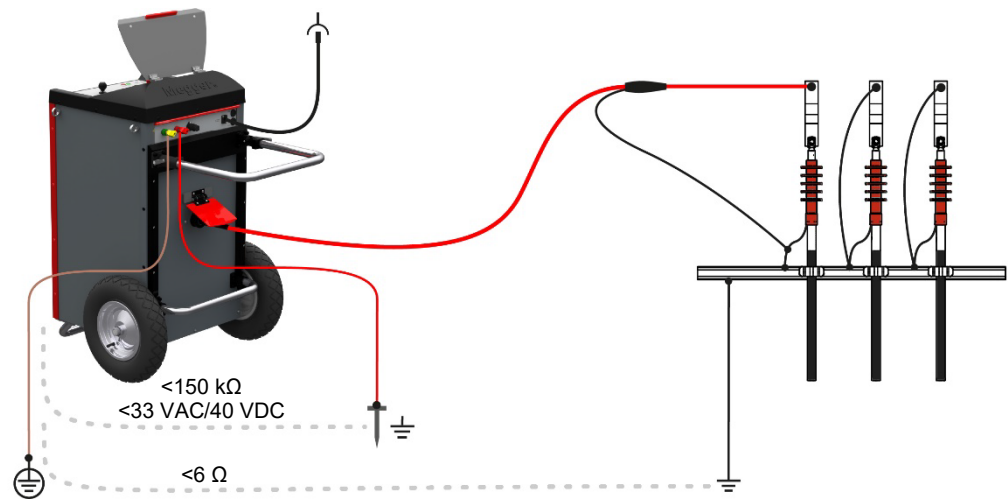

If one of the two protective devices detects that the specified limit values have been exceeded, any high-voltage operation is immediately interrupted automatically and the test object is discharged via a discharge resistor. It is only possible to switch on the high voltage again after the earthing conditions have been improved and the measured values are within the tolerance levels.

Device key For reasons of liability, it must be ensured that measuring devices that emit a hazardous voltage are secured against unauthorised access. For the STX 40, this is done by means of the device key, which must be screwed onto the socket 10 at the rear of the device in order to activate high voltage.

In the event that the device must be left unsupervised for a period of time, this key must be removed and carried by the person responsible for the device.

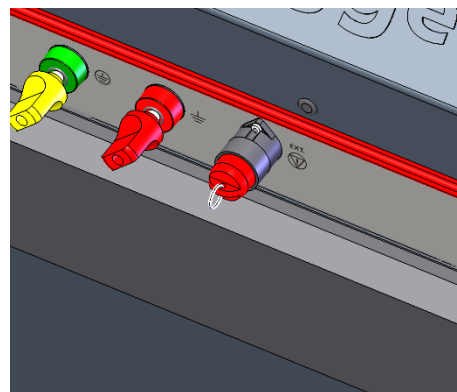

High voltage preparation possible

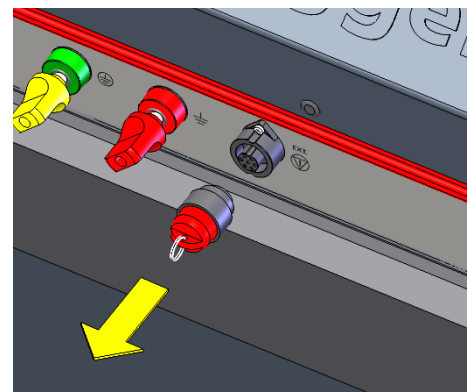

High voltage preparation locked

2.6 Operation in vehicle

The device can also be operated in or on a vehicle if the following requirements are met:

- The vehicle chassis must be connected to the protective earth connection **8** of the device with the lowest possible contact resistance.
- Both earth connections **8** and **9** must be connected to suitable connection points outside the vehicle (see page 20).
- The high-voltage output **13** must be connected directly to the object under test using a HV connection cable provided by Megger with a length of at least 25 m. Connection via a patch panel is not permitted.
- If several individual devices are transported in or on the vehicle, only operation outside the vehicle is permitted for safety and liability reasons!

3 Commissioning



WARNING

General safety instructions for set-up and commissioning

- The safety guidelines for the operation of mobile testing systems often differ from one network operator to another and are frequently subject to national regulations (such as the German BGI 5191). Before the measurement session, find out what the applicable guidelines are and follow the rules set out therein precisely, in respect of the organisation of work and the commissioning of the mobile test system.
- Select a location that is sufficient for the weight and size of the system and which ensures that it stands securely.
- The device may only be operated in upright position!
- When setting up or connecting the device, make sure that it does not impair the functional capability of any other systems or components. If other systems and components have to be modified, be sure to reverse these measures once the work has been completed. Always take the special requirements of these systems and components into account and only carry out work on them after consulting and obtaining approval from whoever is in charge of them.
- In the event of large differences in temperature between the storage and installation locations (cold to warm) condensation may form on components carrying high voltage (condensation effect). To avoid any risk of damage to people and devices caused by voltage flash-overs, the system must not be operated when in this condition. It should rather be left in the new environment to acclimatise for approximately one hour before putting it into operation.

3.1 Electrical connection



WARNING



Safety instructions for the electrical connection

- The system may only be connected to **de-energized** equipment. The general safety instructions and, in particular, the five safety rules (see page 7) must always be followed prior to connection to the test object.
- Follow the specified connection sequence.
- All the cables at the measuring point that are out of operation and are not to be tested must be shorted and earthed.
- Because the amount of voltage applied to the test object poses a danger in the event of contact, the prohibition zone around live parts as defined in DIN EN 50191 (VDE 0104) must be protected in a way that it cannot be breached.
- The ends of the cables must be shielded to ensure that contact is not possible. When doing so, be sure to take all branches of the cables into account.
- The device should never be operated without the earth lead being connected. The earth lead establishes the connection between the device and protective earth and ensures that the device is touch-proof. Earthing provided through the earth contact of the mains connection or an earth spike is not sufficient. An earthing tester can be used to check the protective earthing. Unless reliable earthing can be guaranteed, the entire measurement setup must be considered live. In this case, follow the instructions of the sections related to live working in EN 50110-1. When working under these operating conditions, insulating protective gloves of class 1 (or higher) according to EN 60903 must be worn!

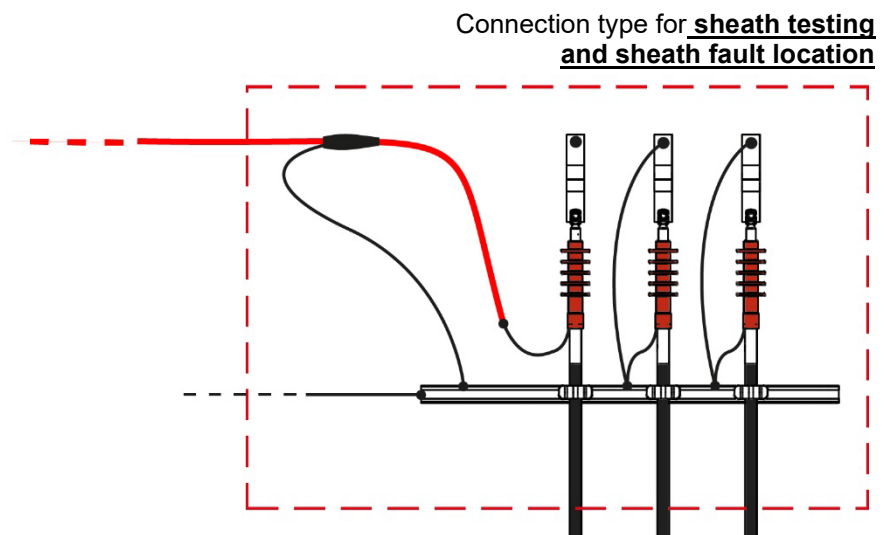
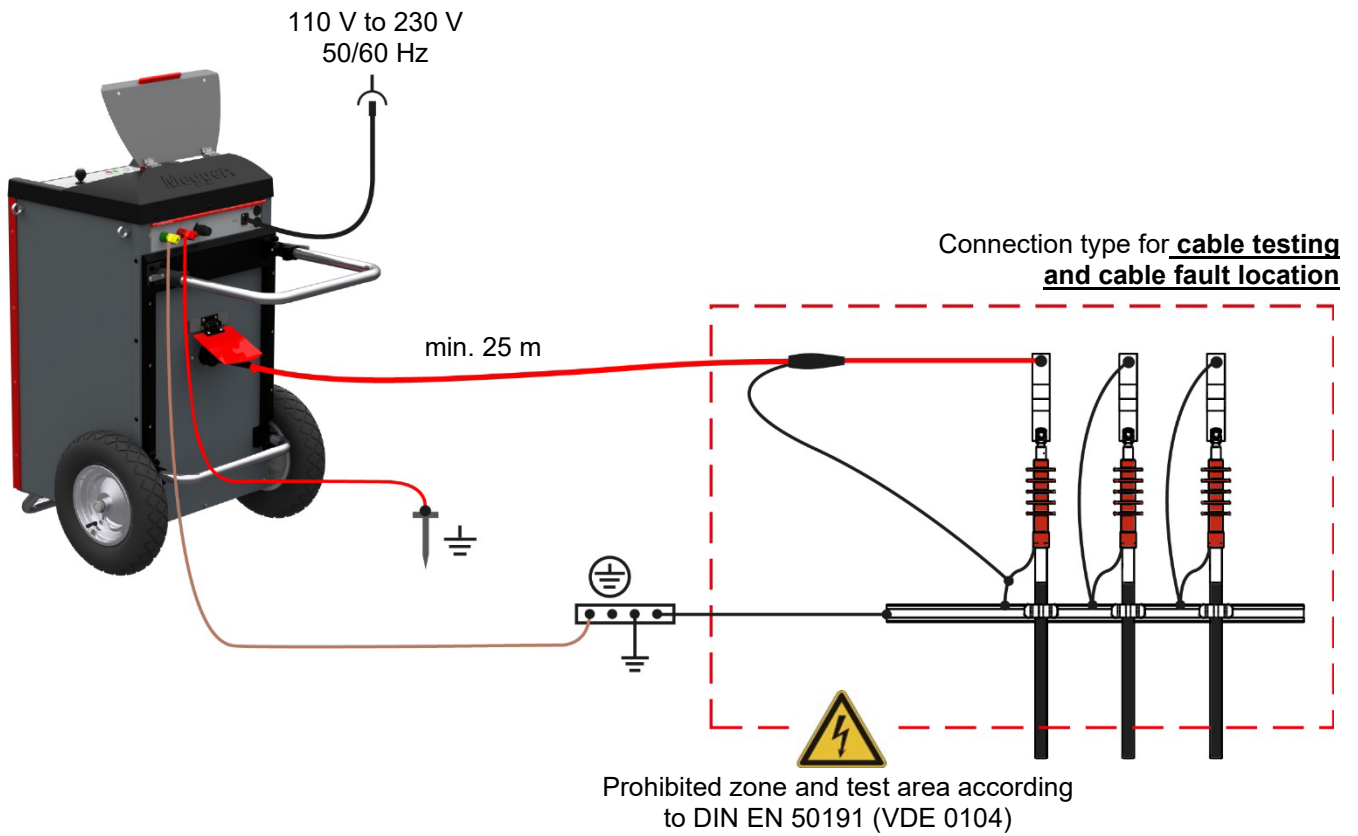
Connection diagram The following figure shows the simplified connection diagram of the fault location system:

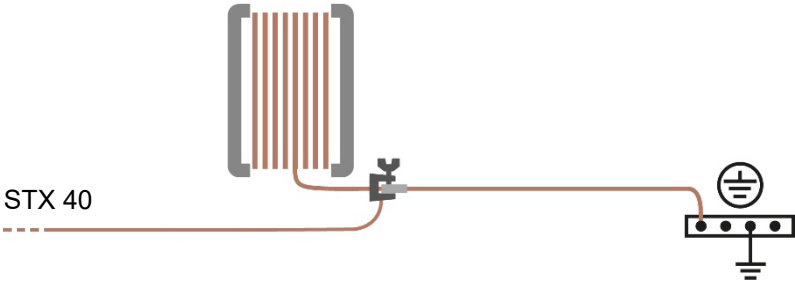

Procedure To connect the STX 40 to the test object, proceed as follows:

Step	Action
1	<p>Connect the device's protective earth connection 8 to a suitable point on the protective earth system (station earth or other suitable foundation earth electrodes).</p> <p>If necessary, the 5-meter earthing cable can be extended using the earthing cable drum.</p>  <p>Ensure that the connection points of the earth cable are not dirty or rusted and provide good metallic contact.</p>
2	<p>Insert the supplied earth probe into the ground as close as possible to the device and connect the earth probe to the auxiliary earth connection via the red reference earth wire 9.</p> <hr/> <div data-bbox="539 1093 603 1167" style="border: 1px solid black; padding: 2px; display: inline-block;"> <p>i</p> </div> <p>The direct connection between the measuring system and the surrounding ground (reference earth) is essential for functioning earth monitoring (FU) and safe measuring operation (see page 17). Even in heavily built-up areas where it is difficult to insert the earth spike, the protective devices of the system must not be bridged or neutralized! The following measures can help to establish a low-impedance earth connection:</p> <ul style="list-style-type: none"> • Use the gaps between concrete slabs to establish good earth contact with the earth spike. • Use water to moisten the location where the earth spike has been inserted. • Connect the reference earth wire to a foundation earth (e.g. a lightning protection system). Do not use the same foundation earth to which you have already connected the main earthing cable.
3	<p>Insert the HV connection cable plug into the HV output 13 and tighten the union nut until hand-tight.</p> <div data-bbox="531 1765 1465 1921" style="border: 1px solid black; padding: 5px;"> <div style="display: flex; align-items: center;">  <p>NOTICE Risk of damage to the device only HV connection cables provided by Megger with a length of at least 25 m may be used for the connection!</p> </div> </div>

Step	Action	
4	If you want to perform a cable test or a cable fault location , ...	If you want to perform a sheath test or sheath fault location , ...
	... connect the shield of the HV connection cable to the earthed shield of the test object (system earth). Connect the internal conductor of the HV connection cable to the phase conductor of the test object.	... connect the shield of the HV connection cable to the earth rail of the cable system to be tested (system earth). Connect the internal conductor of the HV connection cable to the shield of the test object. The earthing of the shield must be removed at both ends of the cable.
5	Connect the supplied power cord to the system's power receptacle 12 and to a power socket.	



3.1.1 Use of an external safety device (optional)

Purpose With the aid of an external safety device, the current status of the system can be made clearly visible with coloured signal lamps (in accordance with EN 50191) and the generation of HV can be interrupted or locked with an EMERGENCY OFF switch and key switch.

Connection To be able to connect the external safety device, first unscrew the device key from the socket ⑩ and then connect the connection cable of the external safety device to exactly this socket. The locking function of the device key (see page 17) is now taken over by the “HV interlock” key switch on the external safety device.

Description The following figure shows the optional external safety device:



Part	Description
①	Green signal light Lights up when the system is switched on but is not in high voltage operation.
②	Red signal light Lights up as soon as high voltage can be generated. All discharge and earthing devices are open and the test object must be treated as live.
③	“HV interlock” key switch <div style="display: flex; align-items: center; margin-bottom: 10px;">  <div style="margin-left: 10px;">High voltage unlocked</div> </div> <div style="display: flex; align-items: center;">  <div style="margin-left: 10px;">High voltage locked</div> </div> <p>In the locked state, the key can be removed and the system can thus be protected against unauthorised high-voltage operation.</p>
④	EMERGENCY OFF switch

3.2 Switch on

Switch on Switch on the device by briefly pressing the on/off button **4**. The software starts within a few seconds and pauses at the main menu after starting.

Indication of possible problems Various safety and monitoring devices are activated from the moment of switching on. Problems detected in the safety circuit or the system components are indicated immediately on the user interface and prevent the operating mode from being started or the high voltage from being enabled, depending on the severity of the problem.

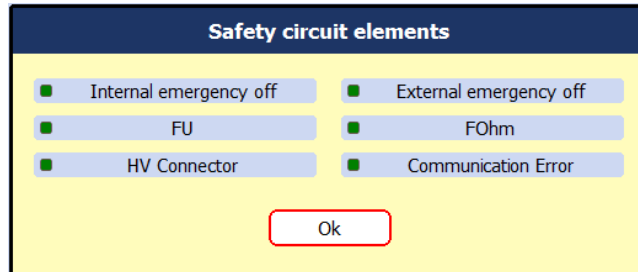

In order to close the dialog and proceed with the actual measuring operation, all signaled problems must first be solved. The status of the respective elements can be read from the color of the status icon:

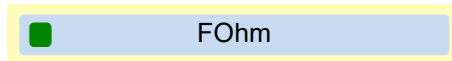

The conditions of this safety circuit element are met and no action is required.

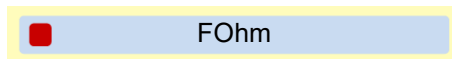

For this safety circuit element, deviations from the conditions required for operation were detected. Use the information in the table below to solve the problem.

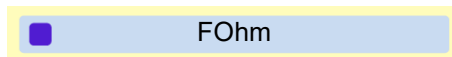

A problem was signaled for this safety circuit element, but it no longer exists. Thanks to this special status, the operator can still identify the element triggering the safety message even if the problem only occurred briefly.

Depending on the problem description displayed, the following actions must be taken:

System reports...	Cause/remedy
<ul style="list-style-type: none"> actuated emergency off switch 	<p>One of the emergency stop switches (on the device itself or on the external safety device) has been activated and must first be reset.</p>
<ul style="list-style-type: none"> actuated external emergency off switch 	<p>One of the following events has occurred:</p> <ul style="list-style-type: none"> Neither the device key nor an external safety device is connected to the socket 10. The emergency stop switch on the external safety device has been activated The "HV interlock" switch on the external safety device has been locked
<p>FΩ monitoring:</p> <ul style="list-style-type: none"> earth resistance too high cable shield not connected <p>FU monitoring:</p> <ul style="list-style-type: none"> potential increase fault voltage dangerous voltage-time area 	<p>Impermissible earth resistances or voltage peaks were measured, which indicate poor earthing conditions. It must be checked that the following connections have been made correctly and provide good earth contact:</p> <ul style="list-style-type: none"> Earth cable Reference earth connection Cable shield of the HV connection cable <div style="border: 1px solid black; padding: 5px; display: flex; align-items: center;">  <div style="margin-left: 10px;"> <p>Never fail to use safety equipment or put it out of operation.</p> </div> </div>
<ul style="list-style-type: none"> high voltage connectors not connected correctly 	<p>The connector of the HV connection cable is not fixed firmly enough into the high voltage output. The connector must engage noticeably when it is inserted.</p>
<ul style="list-style-type: none"> an internal communication error 	<p>An error occurred during communication between the modules within the STX 40. The system should be restarted. If the fault cannot be cleared or occurs repeatedly, an authorised service center must be informed.</p>

3.3 High-voltage control

Release high voltage Immediately after a measurement has been prepared and started by the operator, the green illuminated "HV ON" button 8 indicates the readiness for high voltage release. By pressing the button, the earthing at the HV output is cancelled. This switching state means: **High Voltage!**

Switch off high voltage If certain events occur (e.g. voltage breakdown in the test object, expiry of the defined test duration), the high voltage is automatically deactivated by the system. This also occurs if a problem has been detected in the safety circuit (see above).

By pressing the red illuminated "HV OFF" button 7, HV operation can also be interrupted manually at any time.



The test object is discharged via the internal discharge resistor both during automatic and manual shutdown.



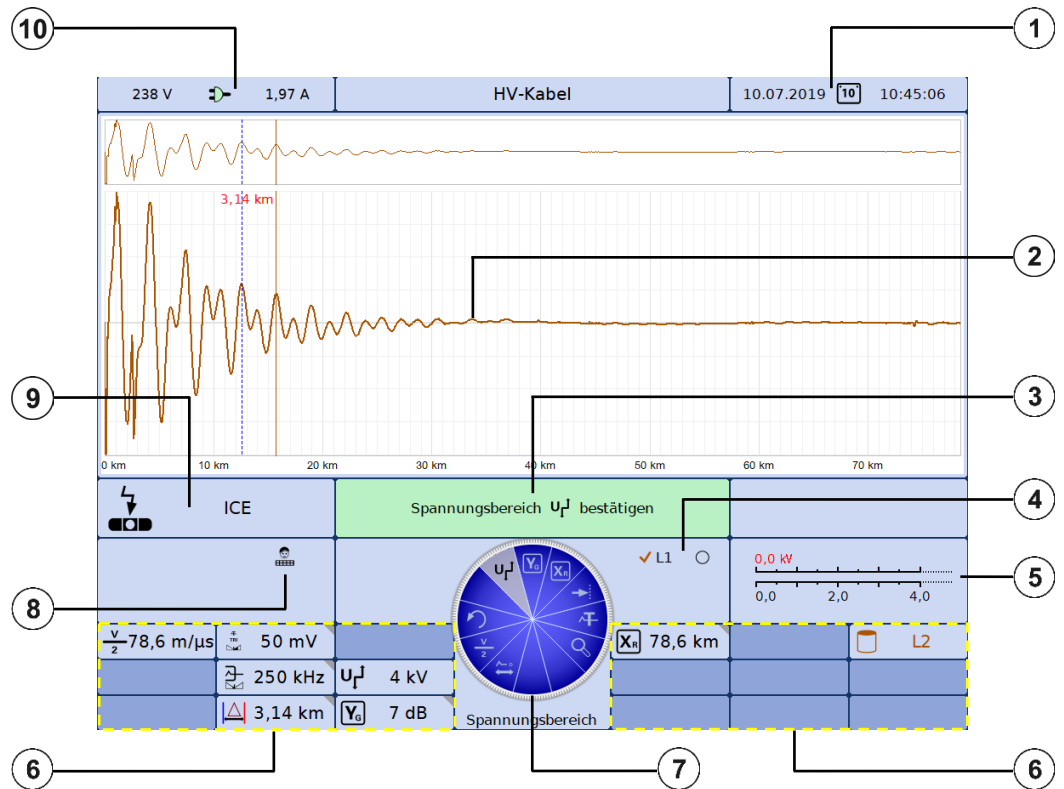

4 Operation

4.1 Screen layout

The following figure shows the typical screen layout:



Segment	Description
①	Date and time
②	Curves of current measurement or loaded measurements. The display is split up into a general overview (top) and in an enlarged section (bottom).
③	Current status messages and information on the next step required in the test sequence.
④	Information on the states of the high voltage outputs. The symbols indicate the following states: <ul style="list-style-type: none">  High voltage generation is switched off and the HV output on the STX 40 is discharged and connected to earth through a resistor.  The resistor discharge is not effective. High voltage is active!

Segment	Description
⑤	<p>Voltage display bar graph</p> <p>Blue bar: Set value</p> <p>Red bar: Actual value</p>
⑥	<p>The display elements arranged in the lower area of the screen may contain the following information:</p> <ul style="list-style-type: none"> • Set measurement parameters • Current measurement values, which are continuously updated as the measurement progresses • Legend of traces currently shown in display (see page 33). <p>Information (such as, e.g. measurement values) which apply for a particular trace only, is shown in the respective colour.</p>
⑦	Selection menu (see page 29)
⑧	<p>Current system state</p> <ul style="list-style-type: none">  The system is currently in standby.  Pulse reflection measurement currently under way.  The measurement was stopped and the traces frozen.  The device is in measurement operational readiness and waiting to be triggered.  The user operating the system has successfully logged into the administration menu (see page 40) and identified himself / herself as administrator.
⑨	Current operating mode
⑩	Current input voltage

4.2 Basics of control system

Selection menu Navigation within the menus is effected almost entirely from the circular selection menu:

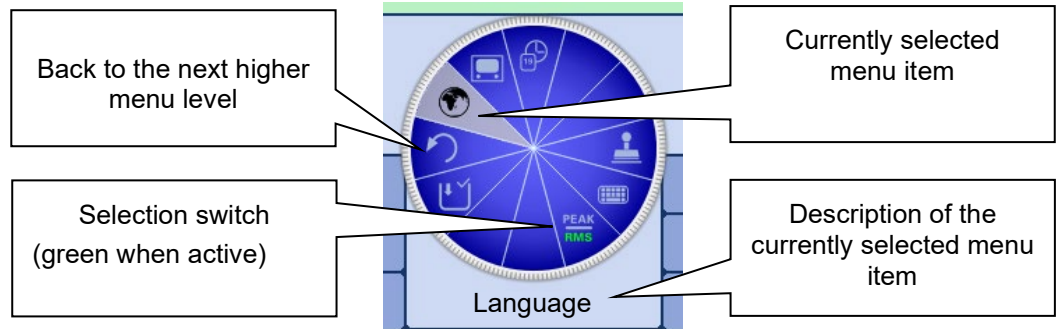

Operation with rotary encoder The system can be operated using the rotary encoder **6** as follows:

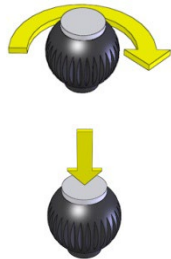

- Select the required menu item
- Increase or decrease the value of a variable parameter
- Select an option from a selection list
- Call up the selected menu item
- Confirm the setting or the selection made

The four side menus are accessed by tilting the rotary encoder

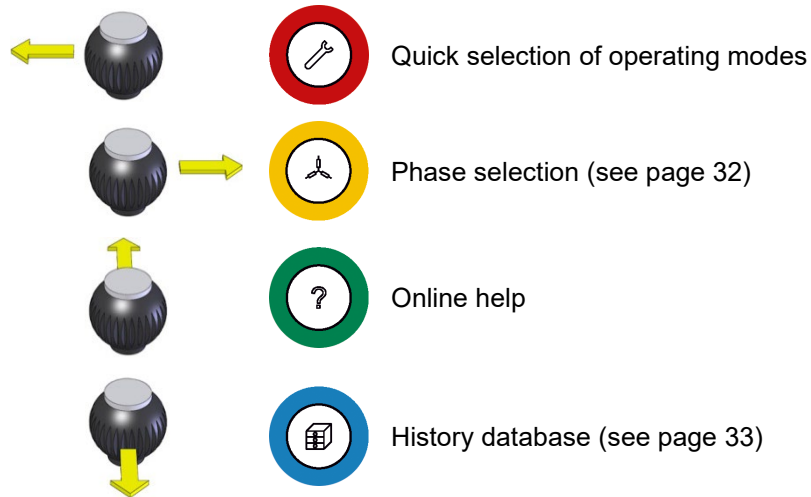

Operation using the touchscreen As the device is equipped with a touch-sensitive display, the software can also be operated just by using your fingers.

Briefly tapping on the buttons in the various menus, and tapping and holding the buttons in isolated cases, allows the respective functions to be activated in the same way as the rotary encoder control.



The four menus at the side can be opened by a swiping motion.

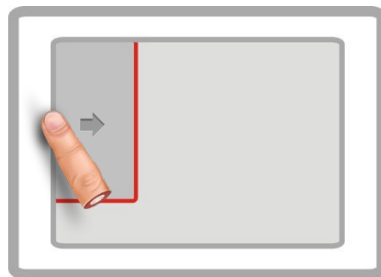

Quick selection of operating modes

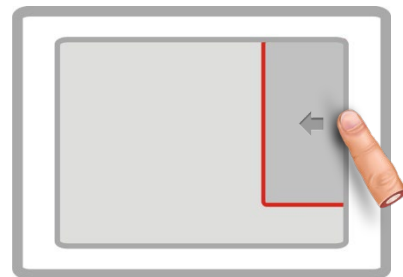

Phase selection (see page 32)

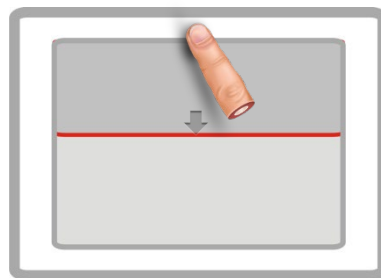

Online help

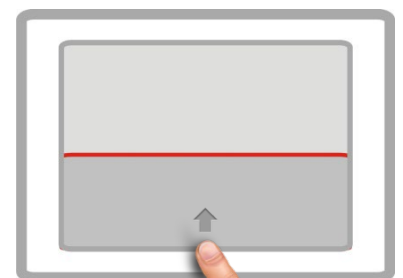

History database (see page 33)

Whenever character strings need to be entered or changed, an on-screen keyboard appears at the lower edge of the display:

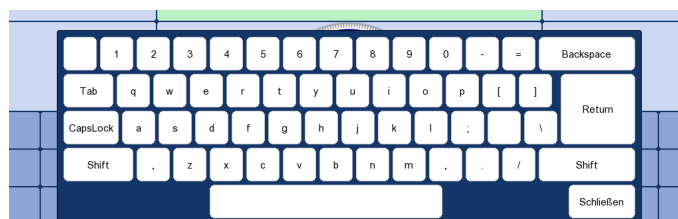

Dialog boxes A few settings, which require values to be entered, are not made directly using the Selection menu, but rather in a separate dialog box.

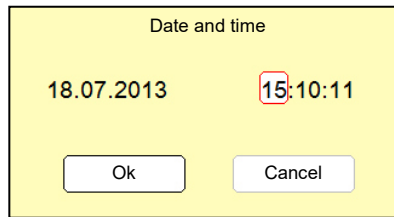

By tilting the rotary encoder **6** to the side the user can switch back and forth between the individual buttons in a dialog box. Each active button is then highlighted in white or it is surrounded by a red frame. Whenever the selected button requires letters or digits to be entered the screen keyboard automatically appears, and it can then be used to make the entries.

To close a dialog box, the corresponding button must be selected and then the rotary encoder pressed.

4.3 Quick selection of operating modes –

Tilting the rotary encoder **6** towards the symbol enables the quick selection menu to be called up at any given time (and to close it again). The menu provides direct access to all available operating modes.

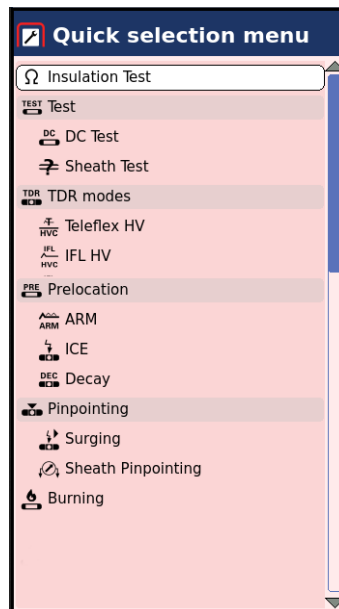

4.4 On-line help –

Tilting the rotary encoder **6** towards the symbol enables the compact on-line help menu with its basic operating information to be called up at any given time.

4.5 Phase selection –

Tilting the rotary encoder **6** towards the symbol  enables the phase selection which can be opened and adjusted till the actual measurement is started.

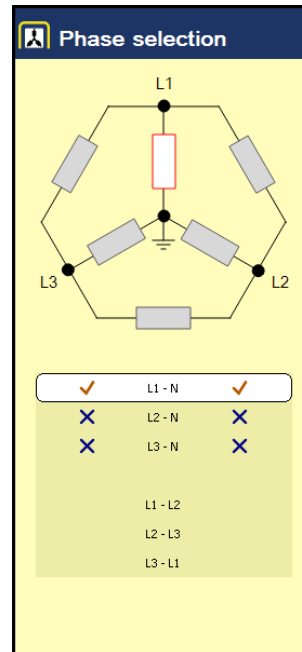

Selecting the phases The desired phase can be marked for selection by turning the rotary encoder and then selected or deselected by pressing it.



Option is active



Option is not active

Only one option can be selected at a time.

Confirming the phase selection Only once a valid selection has been made can the phase selection menu be closed and the phase selection be confirmed by tilting the rotary encoder towards the symbol . Up to the time at which the operating mode starts, the phase selection menu can be called up again and a change can then be made to the selection.



Make sure that the phase selection matches the actual connection situation! Otherwise, the measuring data will be stored with incorrect phase details whereupon the data will not be able to be correctly assigned afterwards.

4.6 History database -

Purpose Each conducted measurement is temporarily stored in the History database and it can be retrieved from there again. This enables the user to access old traces and to compare them with the current traces. The parameters under which the measurement was conducted are also shown.

In addition to the individual measurements, the measurement logs created using the log function are also archived in the History database.

Searching in the History database

Tilting the rotary encoder **6** towards the symbol enables the database to be opened at any given time.

The measurement data records are organised by date in sub-directories.

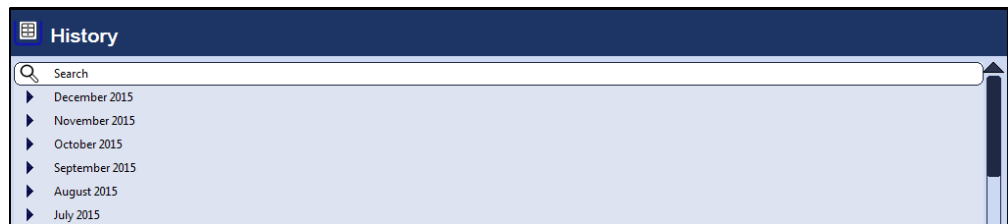



After the desired month and then the desired day have been selected, the measurement data records registered on this days can be searched through and retrieved.

Date and time of measurement	Operating mode	Measurement parameters and results	Storage period (see next page)	Tested phases	Comment
2017/06/06 02:22:41	Teleflex-IFL LV	L1			
2017/06/06 02:15:43	Teleflex LV	L1,L2			
2017/06/06 02:15:27	Teleflex LV	L1			comment
2017/06/06 02:14:36	Teleflex LV	L1,L2			

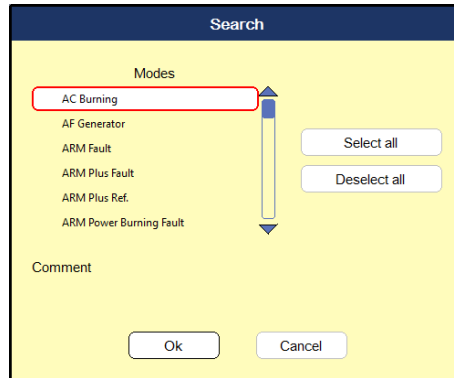

Via the list entry you can always return to the next directory level up.

Via the  list entry you can reach the search mask using which you can search for particular operating modes and comment entries through the data records of the current directory and all sub-directories.









If you are searching for both an operating mode and comment entry at the same time, only those results which fulfil both criteria will be displayed. Holding down the  button will cause the search criteria to be discarded and all the data records to be displayed again.

Storage period The default setting stores the measurement data for 90 days in the history database. The following symbol indicates how long a measurement has already been stored:

Symbol	Description
No symbol	The data record has been conducted within the last 85 days. An automatic deletion is not imminent.
	The data record is at least 86 days old and will be automatically deleted during the next few days.
	The data record is either imported or permanently stored (see page 47). There will be no automatic deletion.

Managing data records In order to delete / export a data record or a complete folder it needs to be selected with the rotary encoder  first. Afterwards, the rotary encoder needs to be tilted to the right or the left until the appropriate marking is shown.

Symbol	Description
	The data record or the folder (incl. all data records in it) is marked for deletion.
	The data record or the folder (incl. all data records in it) is marked for export.
	Several data records within the folder have been marked for deletion.
	Several data records within the folder have been marked for export.
	The folder contains both data records marked for deletion and data records marked for export.

 After selection of the measurements the data deletion or export process must be initiated in the data menu (see page 38). Otherwise the markings will expire the next time the device is started up.

Accessing measurement data from the history database

To access curves and data from old measurements, first access the history database and then use the rotary encoder **6** to select the respective measurement from the directory structure. **Briefly pressing** the rotary encoder enables all the curves and measured data for this measurement to be loaded. To this end, the software proceeds as follows:

- If the operating mode currently selected is the same operating mode in which the loaded measurement was recorded in, the accessed curves are shown together with the currently recorded curves. This enables the results of different measuring operations to be easily compared.
- If the current and the loaded measurement are not of the same operating mode, the current measurement is automatically ended and only the loaded measurement is displayed.
- If there are not enough free slots to display the loaded curves, the currently recorded curves are overwritten. To avoid this, it is advisable to select curves from the History database one by one (see below) so that you can assign them individually to slots that are free or no longer needed.

The colour-coded legend on the bottom right edge of the screen provides information relating to the measured values of the curves currently displayed.

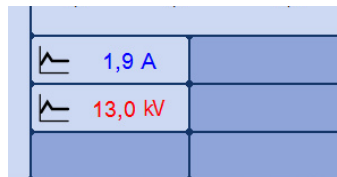

Current and loaded curves can be differentiated between using the symbols in front of them.











Symbol	Description
	Curves which were recorded during the measurement in progress.
	Curves which have been accessed from the history database.

By **Holding down** the rotary encoder a context menu can be opened from which the following special functions can be accessed:

- Add / edit a comment for the measurement
- Access special measurement data or only individual traces of this measurement (possible in certain modes only)

4.7 System settings -





The System menu can be access directly through the  menu item when in the main menu, and it contains the following menu items:

Menu item	Description
	Submenu for managing the measurement data (see page 38).
	Basic settings (see page 39)
	<p>Default values can be adapted for nearly all the system settings. If user management (see page 42) is active then each user can define and store his / her own default values. These defaults are then loaded each time the system starts or a user logs in.</p> <p>The submenu contains the following items:</p> <ul style="list-style-type: none">  This menu item enables the current settings to be stored as default values. Naturally, only the changes made during this session are taken into consideration. <hr/> <p> When saving the default values, note that all values that have been changed since the last system start are saved, which means that you might inadvertently save some changes that you do not want. To be on the safe side, you can first reload the current defaults (see below), make the required settings and then save them.</p> <hr/> <ul style="list-style-type: none">  This menu item can be used by the current user to reload his / her stored default values.  This menu item restores the factory settings.  This menu item enables the default values for the current user to be exported as XML files to the <i>DefaultValues</i> directory of the inserted USB flash drive.  This menu item can be used to import defaults values that are stored on an inserted USB flash drive into the system. The imported values then become immediately applicable. When user management (see page 42) is active, the imported default values are only applicable for the user currently logged on.
	Service menu which can only be accessed by a service technician.
	The administration menu (see page 40) enables a user with the appropriate permissions to access extended system functions.

Menu item	Description
	<p>This submenu enables various settings to be made for scale graduation on the X-axis and for entering the propagation velocity. It provides the following menu items:</p> <p> Depending on the setting of this switch, the X-axis is either scaled in seconds (runtime) or in length units (distance).</p> <p> <u>Only available when the X-axis is scaled in length units (see above)</u> This menu item can be used to switch the unit of the X-axis between meters and feet.</p> <p> <u>Only available when the X-axis is scaled in length units (see above)</u> To achieve reliable distance details, knowledge about the exact signal propagation velocity for the test object is absolutely essential. This can be specified in two different ways:</p> <ul style="list-style-type: none"> • NVP (Nominal Velocity of Propagation) - The signal propagation velocity is stated relative to the speed of light, e.g. NVP 0.53 = 0.53 x c. • SPEED - The signal propagation velocity is stated with half the actual propagation speed (the cable's so-called V/2). <p>Depending on the above settings, a default propagation velocity value can be defined using the menu items $\frac{V}{2}$ and NVP respectively. This value is then preset whenever a measurement is started.</p>
	<p>Submenu for displaying and exporting important system information.</p> <p> Information on software version</p> <p> Information on system hardware and the current IP address</p> <p> This menu item enables messages stored in the System log to be displayed, and exported to an inserted USB flash drive (<i>SystemLog</i> directory).</p>









4.7.1 Data menu -

The Data menu enables stored measurement data to be imported, exported or deleted. It contains the following menu items:

Menu item	Description
DEL	Menu item to enable measurement data records to be deleted from the History database. The measurements to be deleted must be marked beforehand (see page 33).
	Menu item that enables measurement data records from the History database to be exported to the inserted USB flash drive (<i>Winkis</i> directory). The data records to be exported must be marked beforehand (see page 33).
	Menu item to enable measurement data records / logs to be imported. To do so, a window is opened in which the user can navigate through the directories on the plugged-in USB flash drive.
	List of common cable types that can be extended by own cable and insulation types. This eliminates the need to manually enter the propagation speed during cable fault pre-location. Instead, the appropriate cable type can simply be selected from the list and its stored propagation speed automatically applied. Two filters (cable type and cable insulation) can be used to limit the number of cables displayed. Saved cable types can only be edited or deleted with administration rights (see page 40).
	Menu item to enable the cable list (see above) to be exported to a USB flash drive (<i>Cables</i> directory).

4.7.2 Basic settings -

The following menu items can be used to adapt the software's basic settings:



Menu item	Description
	Sets the language. Select the desired language by turning the rotary encoder and activate by pressing it. The language selection is immediately active.
	Date and time.
	This menu item enables the following functions that influence the measurement sequence to be activated or deactivated: <div style="display: flex; flex-direction: column; gap: 10px;"> <div data-bbox="563 685 603 719"> Activates / deactivates automatic scaling adjustment of the X axis as soon as a trace is recorded.</div> <div data-bbox="563 763 603 797"> Activates / deactivates automatic gain adjustment of the Y axis as soon as a trace is recorded.</div> <div data-bbox="563 842 603 875"> Activates / deactivates the automatic positioning of the marker on the suspected fault location as soon as a trace is recorded.</div> </div>
	Layout of the on-screen keyboard. This can be switched depending on the language area in which the system is used.
	This menu item enables the currently logged-on system user to be changed. Once a new user has been selected, the new user's default settings are then loaded. The menu item is only available if at least one user exists in the database. The administrator can manage user accounts in the administration menu (see page 40).

4.7.3 Administration menu - (administration password required)







Purpose The administration menu is password-protected and provides access to advanced system settings such as the user administration, as well as update and backup functions.

The software's menu structure has concealed menu items added to it when administration rights are issued. These enabled functions, which are only rarely used during day-to-day operation of the device, are described in greater detail throughout the course of the manual.

Access To open the administration menu, you must first enter the password. Proceed as follows:

Step	Action
1	Select menu item  , to access the Control Panel and then select menu item  .
2	Select menu item  to enter the password. Result: The password entry dialogue appears in the display.
3	Enter the password and confirm your entry with OK . Result: If you entered the password correctly, the menu items of the administration menu appear (see below). If your entry is incorrect, you must repeat the procedure from Step 2 .

Menu items The Administration menu offers the following menu items:

Menu item	Description
	Software update (see next page).
	Various system data (such as the log file and the configuration file) can be exported to the inserted USB flash drive via this menu item. The directory name consists of the system serial number and a sequential number. These data can provide important information about the cause of the problem when servicing and should be made available to service personnel on request.
	The database can be completely emptied via this menu item, i.e. all measurement results, users, cable types and system logs are deleted. However, calibration and configuration data are retained. Once the function has been called up, the system must be switched off and then on again. After the restart, the database reset must be confirmed once again.
	Menu item used to manage the users accounts (see page 42) of the system.
	Menu item to activate/deactivate the connection lead calibration mode (see page 43).
	Menu item used to disable administrator rights and to protect the administration menu with a password again.







4.7.3.1 Updating the software - $\frac{UP}{DATE}$

Proceed as follows to update the software:

Step	Action
1	Download the latest software from the Megger website.
2	Unpack the update package into the root directory of a USB flash drive.
3	Insert the USB flash drive into the USB port.
4	Call up the $\frac{UP}{DATE}$ menu item in the Administration menu. Result: A selection dialogue appears.
5	Select the option System Software (RPM/DEBIAN package) . The option Single file (file selection) enables the import of individual files, but should only be used in the event of an error and after consultation with a service employee.
6	Start the update via OK and confirm the following message. Result: The system / unit switches off.
7	Switch the system / unit on again. Result: During the boot process, the update package on the inserted USB stick is recognised and automatically installed. Do not switch off the system / device during the update!

4.7.3.2 User administration -

User administration allows you to set up various user accounts on the system, so that each user can adjust the default values and the way the system behaves according to his own preferences.

Menu item	Description
	<p>A new user can only be created if a user name is entered. You can also limit the maximum voltage that the user can adjust and protect the account with a password.</p> <p>If you do not specify a password, the user does not need to enter a password when logging in, which makes the procedure quicker.</p> <p>The default values for the new user are the same as the factory settings. If necessary, you can import (see page 36) the default values from another user account (or even another system).</p>
	<p>This menu item can be used to edit the name, voltage range and password of a user.</p>
	<p>This menu item can be used to delete individual users from the user database. If the last user has been deleted, the user management is deactivated and there is no longer a login procedure when the system is started.</p> <hr/> <div data-bbox="531 1032 600 1115" style="border: 1px solid black; padding: 2px; display: inline-block;">  </div> <p>You can only delete the last user by interrupting the login. When deleting a user, his default values are lost. Therefore – particularly for the last user – you should export the default values beforehand (see page 36) beforehand.</p> <hr/>
	<p>This menu item allows you to export a selection of user profiles from the system together with the respective standard values as an XML file to the inserted USB flash drive's <i>User</i> directory.</p>
	<p>This menu item can be used to import user profiles that are stored on an inserted USB flash drive into the system.</p> <p>This does not affect existing users. If two user names are the same, the system asks whether you want to overwrite or keep the existing user in the system.</p>

4.7.3.3 Connection Cable Calibration -

Purpose A properly calibrated connection cable ensures the accuracy of all operating modes which function according to the TDR principle (Teleflex, IFL, ARM). The length of the connection cable is not only automatically hidden from the visible diagram area, but also automatically subtracted from the calculated distance specifications.

As a principle, a calibration was already performed using the connection cable supplied during the final test. A repeat calibration should only be performed when the connection cable was replaced with a cable with a different length. In this case, an individual calibration must be performed Teleflex mode.

Procedure To calibrate a pre-measuring cable, proceed as follows:

Step	Action
1	Activate calibration mode using the menu item in the administration menu.
2	Select the menu item $\frac{T}{HVC}$ from the submenu in order to start the operating mode.
3	Choose any phase.
4	Perform a measurement with the end of the connection cable open.
5	Exit the operating mode and then open it again immediately. Select the same phase as in Step 3 .
6	Open the trace recorded in the history database beforehand (see page 33).
7	Short circuit the connection cable at its end, and perform another measurement.
8	Select the menu item and move the red cursor exactly to the point at which both traces diverge. Then press the rotary encoder and keep pressing it until the new zero position is applied.
9	Deactivate calibration mode using the menu item in the administration menu.

5 Performing measurements

5.1 Good to know ...

5.1.1 Propagation velocity

Introduction To enable the exact distance between the start of the cable and the fault position to be calculated, the TDR must be aware of the propagation velocity in the cable. This velocity depends on several physical variables in the cable: insulation material and thickness, cable diameter, etc.

If the setting for the propagation velocity value is out by 2%, then the measurement result will also be out by 2%.

Determining unknown propagation velocity If the correct physical length of the cable under test is known, the propagation velocity can be measured. To do so, perform a pulse reflection measurement, and make sure that the end cursor is positioned exactly on the identified end of the cable. The propagation velocity is then continuously altered until the actual cable length is displayed. The propagation velocity should then be noted down for future measurements.

If the length of the cable under test is unknown because of elbows, reserves, etc., then a piece of the same cable can be measured in the workshop and the determined propagation velocity used for the cable out in the field. A reference cable such as this however, should be at least 50 metres in length.

5.1.2 Pulse width

Due to the attenuation and dispersion characteristics of a cable, signals get changed in amplitude and shape as runtime progresses. Naturally, this also applies to the measuring pulse and its reflections.

Narrow pulses, which contain a large portion of high frequencies, are subject to greater deformation than wide pulses. Consequently, narrow pulses are more suited for shorter ranges in which they can provide an image with higher resolution than wide pulses, whereas over larger distances they suffer from greater attenuation and dispersion. Here, wide pulses (up to 10 μs) must be used, as they are subject to significantly lower attenuation and therefore they supply a much clearer echo over longer distances.

The following table provides an overview of the pulse widths recommended for each required distance range:

Required distance range	Recommended pulse width
<100 m	20 ns
100 m ... 200 m	100 ns
200 m ... 1 km	200 ns
1 km ... 2.5 km	500 ns
2.5 km ... 10 km	1 μs
10 km ... 30 km	2 μs
30 km ... 80 km	5 μs
>80 km	10 μs

5.1.3 Typical TDR reflectograms

The following illustration shows several idealised examples for TDR reflectograms:

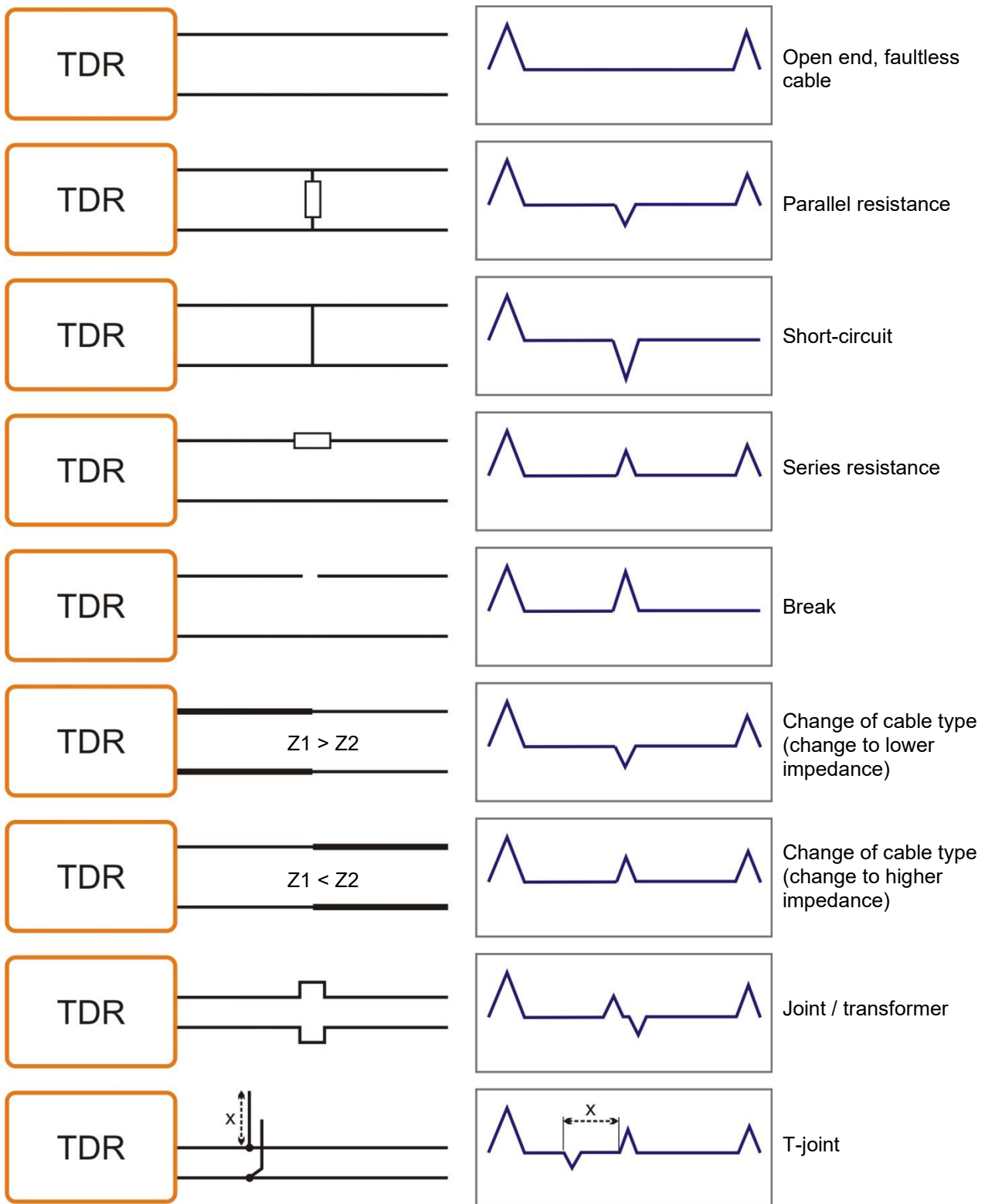

5.2 Standard functions







Generally available functions For all operating modes in which measured data are recorded and displayed, the following standard functions are available in the respective measurement menu:





Menu item	Description
	This menu item can be used to move the cursor along the X axis. The current, voltage, time or distance values of the currently marked position are displayed in the bottom part of the screen.
	This menu item can be used to increase or reduce the visual range on the X-axis. The section aligns itself with the current cursor position here.
M	<p>This menu item can be used to access a list of all data records stored in the History database which match the currently active operating mode. Only the permanently stored data records are taken into account here. Using the rotary encoder enables a data record in the list to be selected and then accessed.</p> <p>This way, e.g. a reference trace previously recorded on the same cable can be quickly located and compared with the current trace.</p> <p>Furthermore, the menu item can be used to store the current measurement permanently in the History database.</p>

Standard functions for pulse reflection measurements Due to the numerous functions, the measurement menus of all operating modes working according to the TDR principle (e.g. Teleflex operating modes, ARM operating modes, ICE and DECAY) feature two additional submenus.













In the actual measurement menu and in the Teleflex menu , all measurement parameters relevant for recording and displaying the curves as well as several additional functions are consolidated. Depending on the operating mode, these menus include a selection of the following menu items:

Menu item	Description
	<p>In all the operating modes in which the measurement has to be triggered (e.g. ARM), the respective trigger threshold can be manually adapted. Normally the trigger threshold is automatically pre-configured to a suitable value. If the measurement should however be interrupted by low voltage reflections which are clearly not induced by the transmitted pulses, then the trigger threshold should be manually increased. If, instead of this, no reflections are displayed at all, then it may be helpful to reduce the threshold.</p>
	<p>This menu item can be used to set the gain.</p> <p>For pulse reflection and ARM measurements, the gain can be set for the received signal. If the setting is good, the reflection for the open cable end can be clearly identified as a positive reflection.</p> <p>In the ICE and DECAY operating modes, any change of the gain setting requires a new fault flash-over to be triggered for the effect to become visible.</p>

Menu item	Description
	<p>This menu item can be used to set the measurement range (X-axis). For pulse reflection and ARM measurements, the end of the cable should be visible as a positive reflection at the right-hand edge of the screen. In the ICE and Decay operating modes, the measurement range should be set to five times - ten times the cable length. Whenever the measurement range is changed, the settings for filter, pulse width, pulse amplitude and de-attenuation are automatically adapted.</p>
	<p>This menu item can be used to move the red cursor along the X-axis. By pressing and holding the rotary encoder a blue mark can be set on the current position of the cursor whereupon the red cursor can then be moved further. In this way, e.g. the real distance between two noticeable positions along the trace can be measured. Depending on the operating mode, the distance (calculated from the runtime) between the two marks is shown in one of the following fields at the lower edge of the screen:</p> <p> The full distance between the blue mark and the red cursor</p> <p> Half the distance between the blue mark and the red cursor (in Decay operating mode only).</p>
	<p>This menu item can be used to set the bandpass filter, which limits the frequency range to be measured. Interference signals outside this frequency range are suppressed. The filter value is reset to its default value as soon as one of the following operations has been performed:</p> <ul style="list-style-type: none"> • change to the operating mode • change to the pulse width • change to the measurement range
	<p>Setting signal propagation velocity (see page 44). The type of entry depends on the system settings (see page 36). The signal propagation velocity can also be adopted directly from one of the cables filed in the Cable database (see page 38). To do so, the menu item must first be called up and then the rotary encoder 6 pressed for at least two seconds.</p>

Menu item	Description
	<p>This menu item can be used to delete individually no longer required traces from the current display, to make it easier to read the important traces.</p>
	<p>The de-attenuation function enables the attenuation of the electrical pulses in the cable to be counteracted. This is done through amplification of the input signal which increases as the runtime increases, i.e. as distance increases the reflections are further amplified. The amplification increases exponentially up to a fixed maximum amplification.</p> <p>The ideal de-attenuation setting depends on the length of the cable, so the de-attenuation setting is effectively adapted whenever the measuring range is changed.</p>
	<p>This menu item can be used for all types of pulse reflection measurement to set the pulse width (see page 45) for the measurement pulse.</p>
	<p>This menu item can be used to manually set the pulse amplitude if required. For fault positions in close range, it may be helpful to experiment with lower pulse amplitudes. Conversely, higher amplitudes are suited for particularly long cables.</p> <p>With each adaptation of the distance range (X-axis) the pulse amplitude is automatically adjusted by the system to a suitable value.</p>

The trace functions menu which can be activated during a pulse reflection measurement using the menu item  provides diverse options to adapt the arrangement of traces on the screen to meet individual requirements:

Menu item	Description
	This menu item can be used to move trace 1 along the Y-axis.
	This menu item can be used to move trace 2 along the Y-axis.
	This menu item can be used to move trace 3 along the Y-axis.
	This menu item can be used to move all visible traces along the Y-axis.
	<p>This menu item can be used to move the traces mapped on the display further apart from each other along the Y-axis and back in position.</p> <p> All traces are separated from each other by 50 pixels along the Y-axis.</p> <p> The traces are moved back into their original position and they are at the same level again.</p>
	This menu item can be used to move all visible traces along the X-axis.
	The difference between trace 1 and 2 is used to calculate and display a new trace. All other traces are hidden here.
	The difference between trace 2 and 3 is used to calculate and display a new trace. All other traces are hidden here.
	The difference between trace 3 and 1 is used to calculate and display a new trace. All other traces are hidden here.
	This menu item can be used to move one of two traces along the X-axis.



Functions which can only be applied to traces 1 to 3 are only available when the respective slots are actually occupied.

Loading a trace from the History database into one of these slots has to be done by calling up the individual trace (see page 33) instead of the complete measurement data record.

5.3 Systematics of cable fault location

Introduction Daily work with a cable test van is divided into the following two main areas:

- **Condition-oriented maintenance**
Testing, diagnosis and partial discharge measurement
- **Event-oriented maintenance**
Localisation of all types of cable faults

While there are many different concepts of and approaches to condition-based maintenance, the approach described below has established itself in event-oriented cable fault location.

Schema The following schema illustrates the typical approach for detection, classification and location of cable faults using the methods of measurement available in STX 40:

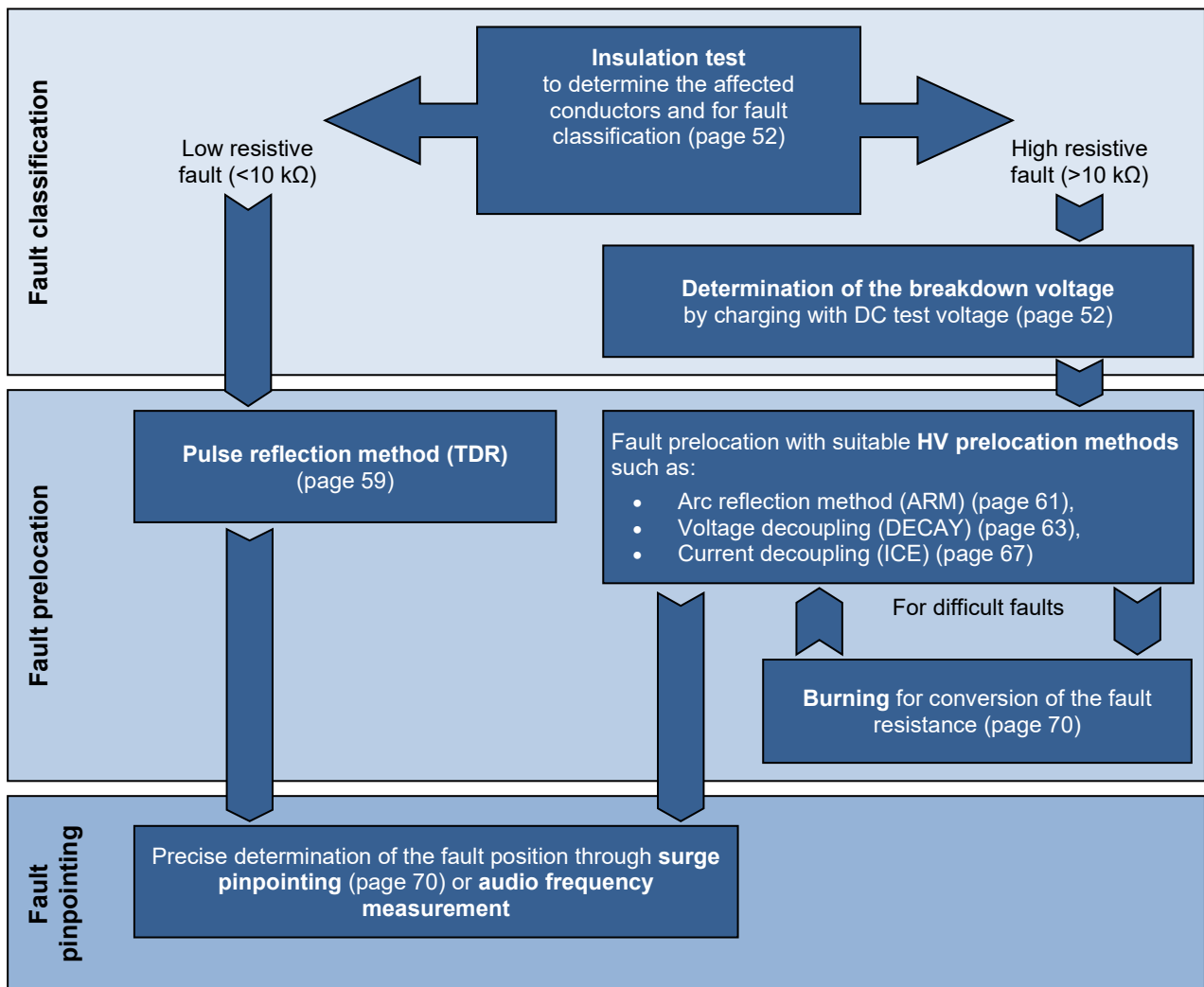

5.4 Insulation test - Ω

Introduction A basic fault classification can often be carried out in advance by measuring the ohmic insulation resistance.



Thus, low- and medium-resistance cable faults can, for example, be directly detected and appropriate follow-up measurements (e.g. Teleflex measurements) can be undertaken.

Even in the event of high-impedance cable faults, conclusions can be drawn about the affected phases based on resistance deviations within a cable system.

It can also be helpful to repeat resistance measurements after application of certain pre-location methods (e.g. ARM, ICE) or fault conversion methods (burning) and to compare the measurement results with those stored in the database.

Call up operating mode and make settings The operating mode can be called up directly from the main menu via the menu item Ω .

The voltage range is queried immediately after entering the operating mode, which limits the maximum voltage that can be set during the insulation test.

If necessary, the phase selection menu can be called up via  in order to set the testing phase actually connected. The phase selection menu must then be closed via .

Performing the measurement The measurement can be started via the menu item  without any previous settings. The high voltage must then be released via the “HV ON” button and the measuring voltage must be set. For safety reasons, the voltage setting dialogue closes automatically after a few seconds, but can be called up again via the menu item U_{NOM} .

As soon as high voltage is enabled, the “HV OFF” button lights up red signalling “high voltage at the HV output”

The system starts with the voltage conditioning. The voltage can also be adjusted during the measurement via the menu item U_{NOM} .

After the resistance value has been read at the bottom right of the screen, the manual switch-off can be carried out using the “HV OFF” button or the menu item $HV\ Off$.

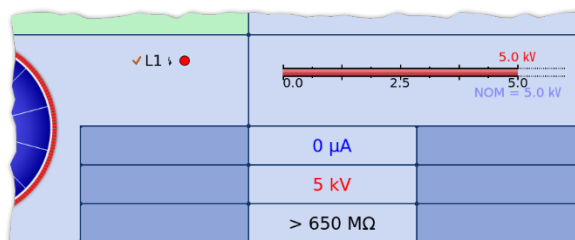

5.5 DC voltage test / breakdown detection

Introduction A DC voltage test not only allows the dielectric strength of the connected test object to be checked, but also the breakdown voltage of the fault location to be reliably determined in the event of insulation problems.

Procedure To conduct a DC voltage test perform the following steps:

Step	Action
1	Call up the menu item from the sub-menu .
2	Set the voltage range that limits the maximum selectable voltage during the test
3	Open the phase selection menu via and select the connected testing phase. Then close the menu by clicking .
4	Use the menu item to set the test time required.
5	Use the menu item to specify whether the test voltage should be automatically ramped up to the set test voltage at an increase rate of 5% of the set voltage range per second (Ramp setting) or you want to manually control the test voltage using the rotary encoder (Manual setting).
6	Start the DC test via the menu item .
7	Release the high voltage via the “HV ON” button.
8	Use the rotary encoder to increase the voltage to the required test voltage and confirm the value by pressing the encoder. For safety reasons, the voltage setting dialogue closes automatically after a few seconds, but can be called up again via the U menu item.
	<p>Result: If the Ramp setting is enabled, the high-voltage source automatically starts charging the cable to the set voltage. Otherwise, the voltage must be manually raised to the desired setpoint. Voltage and current run are shown in the display.</p> <p>If the cable cannot be charged to the set nominal voltage, overcurrent is detected during the test or a voltage breakdown occurs, the test is automatically aborted, the cause of the shutdown or breakdown voltage is displayed and the high voltage is switched off.</p> <p>This also happens after the test time has expired and the test has thus been successfully completed.</p>



5.6 Sheath test and sheath fault detection



Introduction Testing for sheath faults can be performed with a DC voltage of up to 20 kV, which also allows testing on cables with a thicker outer sheath (such as cables with a nominal voltage of 230 kV).

If a voltage leak occurs during a sheath test or if the measured leakage currents indicate a sheath fault, it is possible to start locating the sheath fault immediately after the test.

During peripheral fault detection, DC current pulses are coupled into the earth-faulted shield with an adjustable cycle rate.

With each coupled pulse, the current flowing into the earth around the exit point (fault location in the sheath) forms a voltage drop, the centre of which can be located precisely with the aid of an earth fault detection device and the associated earth probes (step voltage method).

Selecting the operating mode To start a sheath test, the sub-menu of the test modes must be opened via the menu item  and the menu item  must be called up from this menu item.

A peripheral fault location can be started from the sub-menu  via the menu item .

5.6.1 Perform sheath test -



Setting test parameters The voltage range is automatically queried when entering the operating mode, but –, like all other settings, – can still be adjusted until the actual start of the test.

The following test parameters can be set:



Function / menu item	Description
	<p>The phase selection must be made according to the actual connection situation.</p> <p>The phase selection menu must then be closed via .</p>
	<p>The set voltage range limits the maximum voltage that can be set during the test.</p> <p>For this purpose, the following reference values are specified in relevant standards (such as VDE 0276), which may deviate from local specifications or factory standards:</p> <ul style="list-style-type: none"> • PVC cable ≤ 3 kV • Medium voltage PE cable ≤ 5 kV • High voltage PE cable ≤ 10 kV
	<p>The test duration can be specified within a range of 1 to 60 minutes. In relevant standards (such as VDE 0276), the test duration of a sheath test is indicated at 5 to 10 minutes depending on the cable type.</p>
	<p>This menu item can be used to specify whether the test voltage should be automatically ramped up to the set test voltage at an increase rate of 5% of the set voltage range per second (Ramp setting) or controlled manually using the rotary encoder 6 (Manual setting).</p>

Starting the test Once all settings have been made, the test can be started via the menu item . The high voltage must then be released via the 'HV ON' button and the test voltage must be set.

From the moment of release, the red illuminated 'HV OFF' button indicates 'high voltage at HV output' The high voltage source starts with the voltage conditioning. The voltage can also be adjusted during the test via the menu item U_{NOM} .

Course of the test During the test, the display area shows the voltage curve and the measured leakage current. The test duration can also be adjusted later when the test is running via the menu item  or reset via the menu item .

In addition to the current and voltage values, some other relevant parameters are displayed at the bottom of the screen:

Symbol	Description
	Remaining test duration
	Set test duration

Completing the test If a test time has been defined, the high voltage is automatically switched off after this time has elapsed. A manual switch-off can be performed at any time using the 'HV OFF' button or the menu item **HV Off**.

During both automatic and manual shut-off, the high voltage output is earthed and the test object discharged via the internal discharge resistor. The measurement data recorded until shutdown are written to the History database (see page 33).

Evaluating the test results If the leakage current values during the test are above the limit values set by the cable owner, the tested cable should be investigated in more detail soon or at least included in a shorter inspection cycle.

5.6.1.1 Pinpointing a sheath fault - ↻

Setting the measurement parameters

The voltage range is automatically queried when entering the operating mode, but –, like all other settings, – can still be adjusted until the actual start of the tracking.

The following measurement parameters can be set:

Function / menu item	Description
	<p>The phase selection must be made according to the actual connection situation.</p> <p>The phase selection menu must then be closed via .</p>
	<p>The set voltage range limits the maximum voltage that can be set during the tracking.</p> <p>For this purpose, the following reference values are specified in relevant standards (such as VDE 0276), which may deviate from local specifications or factory standards:</p> <ul style="list-style-type: none"> • PVC cable ≤ 3 kV • Medium voltage PE cable ≤ 5 kV • High voltage PE cable ≤ 10 kV
	<p>This menu item can be used to set the cycle rate of the dc pulse in seconds.</p> <p>For example: At a clock rate of 1:3, each 1 second DC pulse is followed by a 3 second pause.</p>
	<p>This menu item can be used to activate/deactivate the current cycle. If the clock is deactivated, the cable is simply supplied with untimed DC voltage.</p>
	<p>Limiting the maximum current (50 ... 850 mA).</p> <p>If the set value is exceeded, the tracking is automatically cancelled.</p>

Starting the pinpointing After all settings have been made, the pinpointing can be started via the menu item . The high voltage must then be released via the 'HV ON' button and the test voltage must be set.

From the moment of release, the red illuminated 'HV OFF' button indicates 'high voltage at HV output' The high voltage source starts with the voltage conditioning. The voltage can also be adjusted during the further course of the pinpointing via the menu item U_{NOM} .

Locating the sheath faults After the high voltage has been released and the desired voltage has been set, the fault position can be located precisely with the aid of an earth fault detector (e.g. ESG NT).



For detailed information on the use of the earth fault detector, please refer to the relevant operating instructions.



WARNING

The safety of the system in operation must be ensured permanently by the person responsible for the work in accordance with the applicable safety regulations and guidelines, including during line and fault location.

Stopping the measurement After the fault location has been completed, the high voltage must be switched off manually using the 'HV OFF' button or the menu item **HV Off**. The high voltage output is then earthed and the test object discharged via the internal discharge resistor.

5.7 Pulse reflection measurement (TDR) -

Introduction Low-resistance cable faults can be localised using the tried-and-tested and widely-used pulse reflection measurements. This method is based on the radar principle and makes use of the fact that any sudden deviations in the characteristic impedance of a cable reflect part of the energy transmitted into the cable. The degree of reflection is dependent on the magnitude of the deviation in the characteristic impedance, the number of reflections, the cable length and the distance to the fault position.

The recorded curve shows any deviation in the cable's characteristic impedance. Naturally, this means that not only fault positions, but also other changes in resistance such as, e.g. in joints are also recorded. These recordings can indeed also represent an additional orientation aid for accurate pinpointing of the fault position.

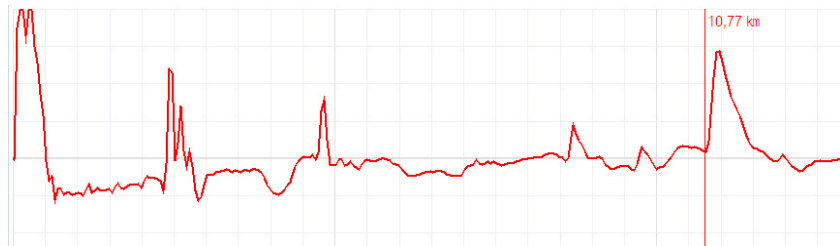

The special IFL operating mode (Intermittent Fault Locating) can be used to localise sporadically (time-variant) occurring low-resistance cable faults (caused, e.g. through traffic vibrations).

To this end, the individual curves in this operating mode are not continuously updated, but rather they form an enveloping curve from all the recorded measurements. In this way, any changes that occur (e.g. temporary fault triggering) during continuous measurements are rendered visible for the user.







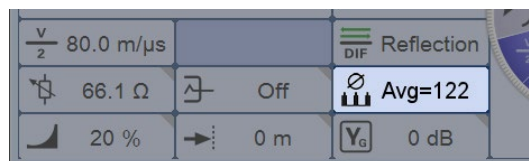

Averaging In the operating mode $\frac{F}{HVC}$ the averaging function can be activated or deactivated using the menu item . When averaging is active, the curve shown on the display presents the average of all previously recorded measurements. A maximum of 256 measurements are taken into consideration here. After reaching this figure, the recording stops automatically.

The number of measurements taken into consideration for the averaging function is shown at the bottom area of the display and it is continuously updated.



Performing measurements Proceed as follows to perform a pulse reflection measurement:

Step	Action
1	In the sub-menu TDR  , call up the menu item $\frac{\text{HVC}}{\text{HVC}}$ (normal measurement) or $\frac{\text{IFL}}{\text{HVC}}$ (IFL measurement with envelope curve).
2	Open the phase selection menu via  and select the two conductors of the test object to which you have connected. Then close the menu by clicking  .
3	Use the Teleflex menu (see page 47) to make appropriate settings for the propagation speed, pulse width, pulse amplitude and filter, and enable the averaging function (see above) if necessary.
4	Start the measurement using the menu item  .
5	Release the voltage conditioning using the 'HV ON' button. Result: Measurement pulses are continuously coupled into the phases involved in the measurement. Depending on the operating mode, the recorded curves are either continuously updated or combined into an envelope curve.
6	Examine the recorded reflectogram for deviations (see page 46) and use the available functions (see page 47) to improve the accuracy and display of the curve, if necessary. In IFL mode, you may try to trigger an intermittent fault by appropriate means.
7	Stop the measurement using the menu item  Result: The measurement is interrupted and the current curve is frozen. If necessary, the measurement can be continued via the menu item  .

5.8 Pre-location of high-resistance cable faults -

In order to perform accurate pinpointing of the cable fault in as small a segment of the cable route as possible, a thorough prelocation procedure should be conducted beforehand. This achieves a significantly shorter total location time while also protecting the cables.

High-resistance cable faults reflect the low voltage pulses of a normal pulse reflection measurement either inadequately or not at all, so that the fault location cannot be identified using the recorded reflectogram. In this event, several other pre-location methods have established themselves, each of which combines a high-voltage process with the pulse reflection method. All these methods force arcing at the fault location through a “breakdown” caused by a sudden discharge of a charged capacitor or by charging the cable. Because the fault assumes the state of a low-resistance cable fault for a short time, its position can be measured beyond this period with a pulse reflection measurement.

The fault position can also be pre-located with sufficient accuracy using the oscillating travelling wave between the fault location and the measurement system that is triggered after the voltage breakdown.

5.8.1 Arc reflection measurement (ARM) -

Introduction The ARM method is suited for the pre-location of high-resistance cable faults on power cables with a total length of up to 10 km. For faults with low ignition voltage (<32 kV), pre-location should be started with this method.

When locating the fault position a reflectogram is taken first under normal conditions (reference trace). The charged surge capacitor is then discharged suddenly into the cable and 32 reflection measurements are carried out in the static arc caused by faulty ignition. The user can then select the most suitable fault pattern from the 32 recorded patterns.

The direct comparison of reference and fault pattern usually makes possible immediate, clear identification of the fault location, because, due to the reflection at the burning arc, the fault pattern displays a significantly negative reflection at the fault location compared to the functional image.

Delay between TDR measuring pulses Before recording a fault trace, the user can manually configure the delay between two successive pulses using the menu item . This type of delay however, should not be confused with the trigger delay time (see next page), which only delays the first pulse.

In principle it is advisable to record the first series of fault traces with a default delay of 256 μ s.

If required the delay can be varied to suit between 0 μ s and 3.84 ms and a renewed faulty ignition undertaken.

For a setting of 0 μ s the pulses are triggered as quickly as possible one after the other.

The effect of a delay adjustment is best illustrated in the current curve following a voltage flash-over:

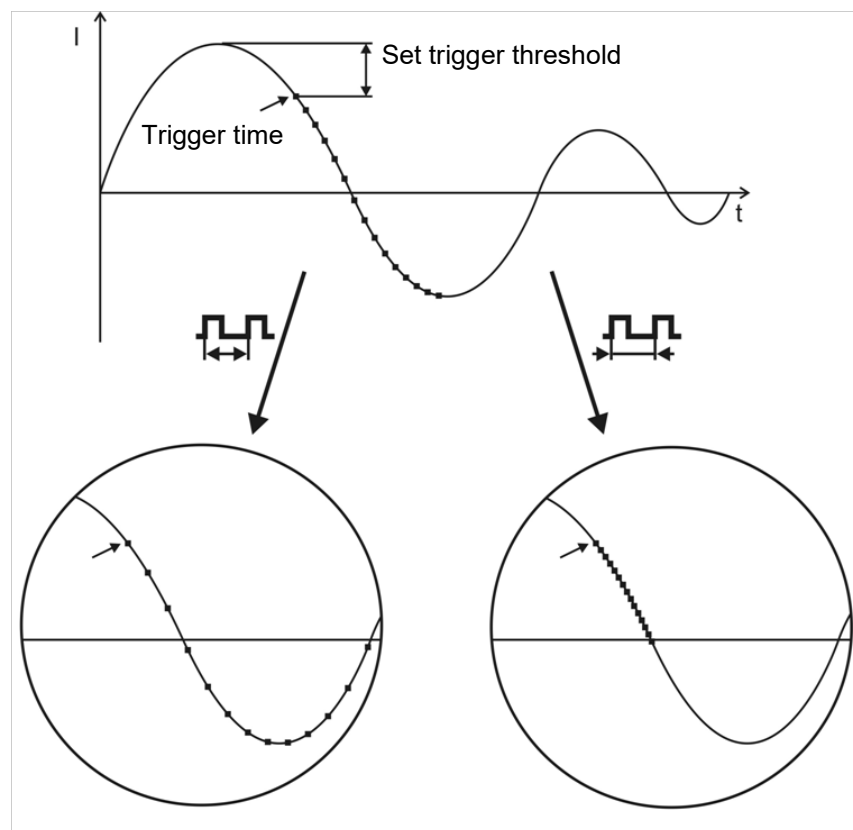

■ Triggering a measuring pulse

As can be clearly seen in the figure, an increase in the delay enables a “wider” period to be mapped, in which the arc - under certain circumstances - is extinguished before igniting again.

Adjusting trigger delay time A user issued with Administration rights (see page 40) can use the menu item to adjust the delay time between the received trigger signal (configured trigger threshold exceeded) and the actual start of the TDR measurement.

This is intended to give the ignition process at the fault position sufficient time to form a stable arc.



Basically, the delay time is set to an ideal setting at the factory for the system configuration and it should only be adjusted in exceptional cases (in very special measurement layouts) and this should be conducted by experienced users only.

Any improper adjustment to the delay time poses the following risks:

- **Delay time too short:** The arc is unstable and the reflectogram is not representative or it is faulty.
- **Delay time too long:** As the delay time increases the risk of conducting a measurement in the decay curve's zero crossing increases. The ignition procedures repeated at this point in time can falsify the reflectogram. If the delay time is excessively high there is also a risk that the arc may already be completely extinguished.

Procedure To locate a cable fault using the ARM method, perform the following steps:

Step	Action
1	Connect the STX 40 to the faulty phase of the test object.
2	Call up the menu item from the sub-menu .
3	Set the voltage range to a few kV above the detected ignition voltage in order to select the lowest possible voltage level and thus ensure the highest possible shock energy. For non-chargeable cable faults, you should increase up to the fault ignition voltage in multiple iterations.
4	Open the phase selection menu via and select the connected phase of the test object. Then close the menu by clicking .
5	Use the Teleflex menu (see page 47) to make appropriate settings for propagation speed, pulse width, pulse amplitude and filter.
6	Start recording the reference trace using the menu item .
7	Enable the high voltage using the "HV ON" button. Result: Following a brief calibration procedure the reference trace is shown on the display.

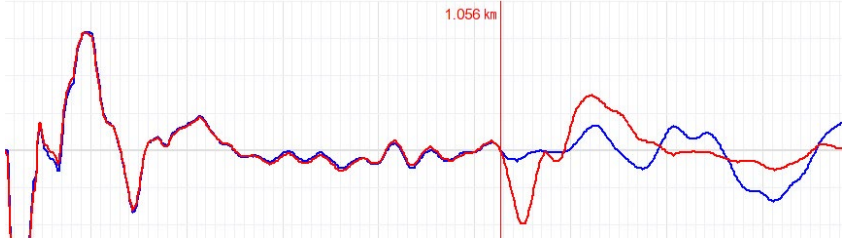
Step	Action
8	<p>Check that the recorded curve, and in particular the marked cable end, match the expected result.</p> <p>If necessary, use the available functions (see page 47) to improve the accuracy and display of the low voltage trace and repeat the recording via the menu item .</p>
9	<p>Prepare the system for fault trace recording using the menu item $\frac{\text{REF}}{\text{FAU}}$.</p>
10	<p>Set the surge voltage while taking into account the required ignition voltage and then trigger the surge discharge via the menu item .</p> <p>Result: If a voltage flash-over occurs at the fault position, a red (fault) curve is shown on the display.</p> <p>If triggering failed to occur, and therefore a fault trace could not be made, it may then be necessary to adjust the trigger threshold or the surge voltage before triggering a further surge.</p>
11	<p>Turn the rotary encoder to select one of the 32 recorded curves and confirm your selection by pressing it briefly. The selected curve can be changed using the menu item  up until the next measurement is started or the operating mode is changed.</p> <p>Result: The red marking is automatically positioned at the location identified as the fault position (at which the two curves diverge).</p> <div style="text-align: center;">  </div>
12	<p>If necessary, use the available functions (see page 47) to optimise the curve display (filter, amplification) and re-adjust the marked fault position. Then read off the fault distance.</p>
13	<p>Switch off the high voltage using the menu item $\frac{\text{HV}}{\text{OFF}}$.</p>

5.8.2 Voltage decoupling (DECAY) -

Introduction The decay method is used to pre-locate high-resistance cable faults using a high fault ignition voltage in rechargeable cables.

To this end, the cable is charged with a DC voltage until the voltage exceeds the fault’s breakdown voltage. The energy stored in the cable capacitance discharges through the fault and generates a travelling wave, which is recorded and displayed by the system as an attenuated oscillation. The period of this oscillation can be used along with the following formula to determine the actual fault distance:

$$Fault\ distance = \frac{Full\ period\ distance}{2} - Length\ of\ HV\ connection\ cable$$

Procedure To locate a cable fault using the Decay method, perform the following steps:

Step	Action
1	Connect the STX 40 to the faulty phase of the test object.
2	Call up the menu item from the sub-menu .
3	Set the voltage range while taking into account the required fault ignition voltage.
4	Open the phase selection menu via and select the connected phase of the test object. Then close the menu by clicking .
5	Use menu item $\frac{V}{2}$ or NVP to set the propagation velocity and then use menu item to set the measuring range to roughly five to ten times the complete length of the cable.
6	Start the measurement using the menu item .
7	Enable the high voltage using the “HV ON” button.

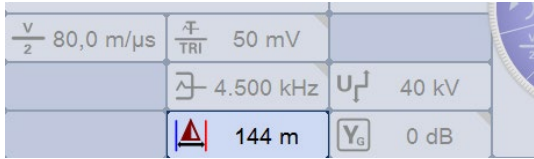
Step	Action
8	<p>Increase the voltage to the desired test voltage using the rotary encoder and confirm the value by pushing in the rotary encoder.</p> <p>The dialogue for setting the voltage closes automatically after a few seconds for safety reasons but it can be accessed again using the menu item U_{NOM}.</p> <p>Result: The test object is charged to the set voltage. Once the fault breaks down, an attenuated and oscillating voltage curve is shown in the display and the voltage conditioning is interrupted.</p>  <p>The software automatically attempts to calibrate a period of the oscillation and to set corresponding markings.</p>
9	<p>Switch off the high voltage using the menu item HV OFF.</p>
10	<p>If the recorded decay curve is superimposed to an excessive degree by interference signals, it uses the available filter settings (see page 47) to smooth the characteristic of the curve. Amplitudes that are too high can be counteracted by reducing the amplification (see page 47).</p> <p>Each time an adjustment is made, you must repeat the procedure from Step 6.</p>
11	<p>If the automatically set markings do not enclose a period exactly, you can use the function \rightarrow to correct their positions.</p> <p>Half the distance of one period is shown directly next to the cursor and in the bottom left corner of the display.</p> 
12	<p>Subtract the length of the connecting cable from this value.</p> <p>The calculated value corresponds to the approximate distance between the connection point and the fault. For technical reasons, this method has a slightly higher tolerance than, for example, pre-location using the ARM method.</p>



5.8.3 Current decoupling (ICE) -



Introduction Prelocation using current decoupling has established itself, particularly with regard to faults in the lower kOhm range and for extremely large fault distances, in which the ARM- method often fails to achieve any results.

As with the ARM method, an abrupt discharge of the surge capacitor triggers a breakdown in the fault. Consequently, an attenuated transient wave moves back and forth between the fault location and the measurement system. Inductively decoupling the current causes the display of an oscillation, which has a period equivalent to a single fault distance. However, the length of the pre-measuring cable still needs to be deducted from this distance.

Procedure Proceed as follows to pre-locate a cable fault using the ICE method:

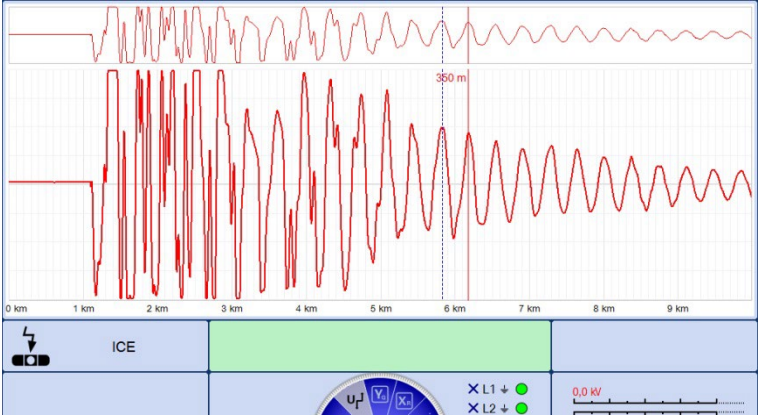
Step	Action
1	Connect the STX 40 to the faulty phase.
2	Call up the menu item from the sub-menu PRE .
3	Set the voltage range to a few kV above the identified fault ignition voltage, to preset a low voltage level and to thus ensure a high surge energy. For non-chargeable cable faults, you should increase up to the fault ignition voltage in multiple iterations.
4	Open the phase selection menu via and select the connected phase of the test object. Then close the menu by clicking .
5	Use menu item $\frac{V}{2}$ or NVP to set the propagation velocity.
6	Use menu item X_R to set the measuring range to roughly five to ten times the complete length of the cable.

Step	Action
7	Start the measurement using the menu item  .
8	Enable the high voltage using the “HV ON” button.
9	<p>Set the voltage, taking the required fault ignition voltage into consideration.</p> <p>If the fault will be caused by surge discharge to breakdown, this needs to be initiated using the menu item  once the surge capacitor has been charged to the set voltage.</p> <p>If instead the cable should be charged to the fault breakdown, the system starts immediately with voltage conditioning.</p>
	<p>Result: If a voltage flash-over occurs at the fault position, the display shows an attenuated and oscillating current curve.</p>  <p>The software automatically attempts to calibrate a period of the oscillation and to set corresponding markings.</p> <p>If triggering failed to occur, and therefore a fault trace was not made, it may then be necessary to adjust the trigger threshold or the surge voltage before triggering a further surge.</p>
10	Switch off the high voltage using the menu item HV OFF .
11	<p>If the recorded decay curve is superimposed to an excessive degree by interference signals, it uses the available filter settings (see page 47) to smooth the characteristic of the curve.</p> <p>Amplitudes that are too high can be counteracted by reducing the amplification (see page 47).</p> <p>Each time an adjustment is made, you must repeat the procedure from Step 8.</p>

Step	Action
12	<p>If the automatically set markings do not enclose a period exactly, you can use the function  to correct their positions.</p> <p>The distance of one period is shown directly next to the cursor and in the bottom left corner of the display.</p> 
13	<p>Subtract the length of the connecting cable from this value.</p> <p>The calculated value roughly corresponds to the distance between the connection point and the fault.</p> <p>For technical reasons, this method has a slightly higher tolerance than, for example, pre-location using the ARM method. With the ICE methods, often 5 ... 10% larger distances are measured, which is why measurement technicians should first walk toward the test van when pinpointing the pre-located fault position.</p>





5.9 Burning -

Introduction What is known as “burning” enables ongoing conversion of high-impedance faults into low-impedance shunts right up to saturated short-circuits. To this end, the fault is first caused to breakdown by charging the test object and then continuously fed a high current, which keeps the arc burning. Ideally, this causes the burned insulating material to form a conductive carbon bridge, thus reducing the resistance of the fault (the fault then becomes locatable) or the moisture that penetrated into the cable evaporates.

Thanks to steady improvement in pre-location methods, this material-stressing method must be used only very rarely with difficult faults, such as moist sleeves.

Selecting the operating mode The burning operating mode can be accessed directly from the main using the  menu item.

Setting the measurement parameters The voltage range is automatically queried when entering the operating mode, but – like all other settings – it can still be adjusted until the actual start of the measurement. The following measurement parameters can be set:

Function / Menu item	Description
	The defective phase must be selected in accordance with the actual type of connection. The phase selection menu must then be closed using  .
	A burn time can be specified in minutes. On expiry of the burn time, the high voltage is switched off automatically.
U_{P}	Voltage range for the upcoming measurement. The actual voltage can only be set within this range.
	Setting the current range. In the Auto setting, the range is always automatically adjusted to the currently measured currents.
I_{MAX}	Limitation of maximum current (50 ... 850 mA) If the set value is exceeded, the burning process is automatically stopped.

Starting and stopping the burning process After all relevant parameters and the faulty phase have been set, the measurement can be started via the menu item . The high voltage must then be released via the “HV ON” button and the nominal voltage must be set. From the moment of release, the red illuminated “HV OFF” button indicates 'high voltage at HV output' The voltage is raised directly to the set setpoint even without prior confirmation.



For safety reasons, the voltage setting dialogue closes automatically after a few seconds, but can be called up again via the menu item U_{NOM} .

The voltage and current curves are shown on the display. When the fault location is ignited, the voltage drops abruptly while the burning current rises sharply. A few minutes are usually enough to convert the fault resistance so that it may be localised using an HV pre-location method.

5.10 Surge pinpointing - /





Introduction Surge pinpointing is the preferred method for precise location. It can be used for about 90% of all cable faults.

Using an abrupt discharge of the surge capacitor, surge voltage pulses are continuously fed into the defective cable, causing voltage arc-overs at the fault location. The resulting flashover noise propagates in the ground and can be recorded with a ground noise sensor on the surface (acoustic location). The distance to the fault can be calculated using either the volume of the flashover noise or the time difference between the arrival of the magnetic pulse and the flashover noise.

Selecting the operating mode The surge operating mode can be called up using the menu item  from the sub menu .

Setting the measurement parameters The phase and the voltage range are automatically queried when entering the operating mode, however – like all other settings – they can be adjusted until the actual start of the test.

The following test parameters can be set:

Function / Menu item	Beschreibung
	The defective phase must be selected in accordance with the actual type of connection. The phase selection menu must then be closed using  .
	Voltage range for the upcoming surge pinpointing. The actual surge voltage can only be set within this range. Set the voltage range to a few kV above the identified fault ignition voltage, to preset a low voltage level and to thus ensure a high surge energy.
 AUTO	Switch between automatic and manual surge decoupling. With automatic surge decoupling, the desired distance between two surges (surge rate) can be set down to the second using the menu item  .



Carrying out fault pinpointing

The safety of the system in operation must be ensured permanently by the person responsible for the work in accordance with the applicable safety regulations and guidelines, including during line and fault location!

In order to avoid subjecting the cable to unnecessary stress, surge mode should not be activated until the measuring technician has reached the prelocated fault position.

Once the operating mode has then been started via menu item , the high voltage must be enabled via the “HV ON” push-button and the target voltage set. The dialogue for setting the voltage closes automatically after a few seconds for safety reasons but it can be accessed again using the menu item U_{NOM} .

As soon as high voltage is enabled, the “HV OFF” button lights up red signalling “high voltage at the HV output”. The surge capacitor is directly charged to the set surge voltage.

Using the menu item , the automatic surge mode is started and a voltage breakdown is caused at the fault location in the set surge interval. In manual surge mode, each surge discharge must be initiated manually using the menu item .

During surge operation, the fault position can now be pinpointed in the pre-located area using a suitable surge wave receiver.



For more details about operating the surge wave receiver, please read the accompanying instructions.

The measurement technician who remains in the test van should maintain telephone contact with their colleagues at the fault location and if necessary modify the settings (surge voltage, surge mode, surge interval), initiate individual surges or pause/continue surge operation.

6 Completing the work

Exporting and processing measurement data

After the actual measurement job, the recorded measurement data can be conveniently analysed, archived and summarised in a report on a Windows PC.

To do this, the desired data must first be marked for export in the History database (see page 33) and then exported to an inserted USB flash drive via the data menu (see page 38). On the Windows PC, the data can then be imported into the protocol software and processed further. Depending on the version of the protocol software, the following functions are available:

	Megger Book Lite <small>(free download on the Megger website)</small>	Megger Book <small>(full version)</small> <small>(article number: 2015875)</small>
Analysis of the measurement data with practical tools	●	●
Creation of a report based on extensively customisable report templates	●	●
Creation and maintenance of a cable database		●
Archiving of measurement activities in the data stock of the respective cable		●

Switching off the system and disconnecting from the test object

After the measurements have been completed, the STX 40 can be switched off by pressing the on/off button **3**.

When disconnecting the test system, proceed in reverse sequence to the manner in which the connection (see page 20) was made. The following safety instructions must be strictly adhered to.

	<ul style="list-style-type: none"> • Follow the five safety rules (see page 7). • Even if switched off properly and discharged using the discharge device, the system components that were under voltage should only be touched once they have been discharged using a suitable discharge rod as well as having been earthed and short-circuited. • Only undo the earthing and short-circuiting measures when the test object is to be operated again.
--	---

7 Transportation, storage and care

Transportation The vertical position of the rear handle can be adjusted to allow an ergonomic stance when pushing or pulling the device. To do this, simply loosen the locking screws slightly on both sides and tighten again after adjusting the height.



The device can be transported over long distances (e.g. in vehicles) in either a vertical (standing) or horizontal position.

The four eyelets on the top of the device can be used to load the device onto a vehicle via lifting equipment.

Note

Risk of damage

The bearing capacity of the eyelets can only be guaranteed as sufficient if the lifting equipment is secured to all four eyelets, as this allows the weight to be distributed evenly.

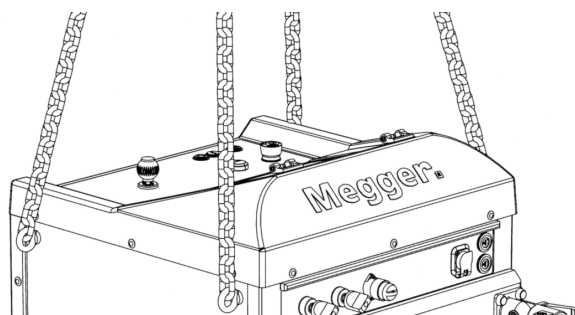

The eyelets can also be used to secure the device when transporting it in a vehicle.

Storage If the system is not used for a long period of time, it should be stored in a dust-free and dry environment. Persistent humidity, especially in combination with dust, can reduce critical insulation gaps that are essential for safe high-voltage operation.

Care of the display Do not clean the display with harsh cleaning agents such as solvents or gasoline.

Instead, lukewarm water with some washing-up liquid should be used and applied to the display using a microfibre cloth.

8 Troubleshooting and maintenance

Replace fuses If the system cannot be switched on even though the mains supply is connected, check the two fuses next to the mains socket **11**. To do this, the fuse holder must be pulled out.

If the fuses are defective, they must be replaced with suitable fuses (T16A 250V, type SPT 6,3x32mm).

If the fuses continue to trip, please contact an authorised service centre to have the fault rectified.

Behaviour in the event of continuous faults In the event of damage, irregularity or faults that cannot be rectified using the instructions in this manual (see page 25), the system must be immediately taken out of service and marked accordingly. Please contact the Megger service immediately to correct the problem. The system must not be put back into operation until the fault has been rectified.

Repair and maintenance Repair and maintenance work has to be carried out by Megger or authorised service partners using original spare parts only. Megger recommends having the system tested and maintained at a Megger service centre once a year.

Megger also offers its customers on-site service. Please contact your service centre if needed.

The connections and connection leads of the system must be regularly checked for integrity and the absence of damage in accordance with the applicable national and company agreements.

