



Electronic Commissioning Unit

Instructions

1. **The Comdronic AC6 Electronic Commissioning Unit**
2. **Health and Safety**
3. **Description of Unit**
4. **Connection and Set-up Procedure**
5. **Menu System**
6. **Display Options**
7. **Automatic Balancing**
8. **Spares and Accessories**
9. **Technical Specification**
10. **Statement of Conformity**
11. **Contacting Comdronic**
12. **Glossary of Terms**
13. **Glycol/Water SG chart**
14. **Index.**

1. The Comdronic Unit

The Comdronic AC6 electronic commissioning unit has been developed in response to demand from discerning commissioning engineers requiring an improvement in measuring techniques for differential pressures in heating and air conditioning systems.

The Comdronic AC6 unit utilises state of the art technologies in the field of electronics, software and hydraulic protection for the sensitive measuring element.

The use of the latest wet/wet sensor technology has opened up possibilities for extremely accurate measurement of differential pressures, however, the delicate nature of this type of sensor design means that damage can easily occur if the correct operating procedure is not followed. To overcome this threat to the sensor the Comdronic AC6 unit has a unique protected crossover valve arrangement (DSP Technology™) designed to protect the sensor in the event of damaging high differential pressures being present.

The Comdronic AC6 commissioning unit has been designed with electronics, microcomputer and hydraulics in one small, lightweight and highly portable unit suitable for efficient commissioning of water systems in buildings.

The Comdronic AC6 unit is supported by an exhaustive database of the world's valves, which can be quickly added to using Comdronic software.

For advanced users wishing to operate on a project basis an optional Bluetooth module is available which will allow communication with either another Comdronic AC6 unit or with a laptop PC. This feature can also be useful when it is necessary to monitor the readings from a remote valve. (Range nominal 100mtrs)

2. Health and Safety

Comdronic takes every reasonable precaution to ensure that AC6 commissioning units are designed, constructed, calibrated and tested for safe and trouble free operation when used in accordance with the operating instructions.

For safe operation it is important that commissioning engineers read and understand the instructions contained in this manual. It is also very important that those employed in the function of commissioning are aware of the general hazards associated with the systems being commissioned.

When working with the AC6 it is the users responsibility to ensure that any Personal Protective Equipment (PPE) or clothing is worn as appropriate to the hazards potentially present.

It is also the user's responsibility to understand the Health and Safety issues relating to water systems that contain water at high pressures, water containing flushing agents, cleaning agents, antifreeze agents and water that might be at elevated temperatures. This list is however, not exhaustive.

Please note: Whilst every effort is made to ensure that valve data is correct Comdronic cannot be held responsible for modifications, updates and new product additions. Valve manufacturers invariably reserve the right to modify product, as such, delays in updating the Comdronic software may result. The user is advised to check performance data (Kvs values) of specific valves prior to use. Contact us for valve updates.

3. Description of Unit

The Comdronic AC6 Unit comprises the following:

- Hand held transducer and display unit
- Quick connect tubing set complete with manually operated isolation valves
- Quick connect angle pattern 3.3 mm insertion probe units
- Instruction manual
- Quick start instruction set and menu map

4. Connection and Set-up Procedure

The Comdronic AC6 unit is supplied with a PP3 9v battery which has to be fitted prior to operation. Remove two screws from battery compartment and fix battery carefully into cut-out in the circuit board. Ensure that battery cable does not become trapped when the battery cover is replaced.

Press any button to switch the unit on.

Press the 'X' button to switch the unit off.

Use the menu to show the display options.

Press help at any time for context sensitive help files. Use up and down buttons to scroll help file.

System Defaults

The AC6 unit has been set up with default values for all the editable functions and are listed as follows:

Language = English
Pressure = kPa
Flow = l/s
Temperature = Celcius
Design flow = 0 l/s
Target flow = 0%
Flow alerts = on
Light timer = 10 minutes
Auto off timer = 10 minutes
Dp cutoff = 30 Pa
Update time = 1 second
Sample time = 3 seconds
Specific gravity = 1.00

The above default settings are satisfactory to use immediately. Please read all instructions to establish the effects of editing the above values.

Automatic alerts

In addition to the menu options which can be selected by the user there are a series of automatic functions which will be displayed on the message bar at the top of the screen. These include:

Zero sensor
Low battery
Change battery
Specific gravity (displays when not set to 1.0sg)

Connection

- Select the correct connection adaptors for the device being measured.
- Attach adaptors to the connection tubes before attachment to the valve or measuring device.

Each connection tube is fitted with an isolating valve which can be arranged so that the valves are adjacent to either the AC6 unit or the subject measuring device. The choice is a matter of personal preference and/or site conditions. ENSURE THESE ARE IN CLOSED POSITION WHEN CONNECTING TUBES TO SYSTEM.

- Attach the red plastic connection tube to the high pressure test point on the subject measuring valve or device.
- Attach the blue plastic connection tube to the low pressure test point on the subject measuring device.
- Ensure both isolating valves on the connection tubes are in the **CLOSED** position.
- Attach AC6 Unit to the free end of the red and blue connection tubes and ensure that the equalising valve is **OPEN** (turn anti-clockwise).
- Open isolating valves on red and blue connection tubes.
- Because of the differential pressure across the subject measuring device flow will now occur through the connection tubes from high pressure side to low pressure side thus expelling air.
- Close isolating valves on both red and blue connection tubes.

The AC6 unit is now correctly connected and can now be switched on ready for the 'zeroing' function.

SAFETY NOTE:

Removal or attachment of a single connection tube when isolating valves are open can result in automatic operation of the DSP Technology™ sensor protection system and water will be ejected from the unconnected port. This mechanism is designed to protect the sensitive measuring sensor.

For full functionality refer to menu system and features below.

Quick start-up (Follow this procedure after connection as above)

Quick start-up will give immediate access to differential pressure measurement.

- Switch on the AC6 Unit – simply press any button- the welcome screen will appear.
- After a short period for initialising the AC6 unit will prompt for zeroing to be carried out. Ensure both connection tube valves are closed and the equalising valve is open.
- Press the 'Zero' button- the dp and flow readings will now show zero.
- Open the isolating valves on the connection tubes.
- Close the equalising valve.

The Comdronic AC6 unit will now be reading differential pressure. (Note. When extremes of temperature change are apparent ie when used on hot system or if the instrument is transferred from warm environment to cold environment it may be necessary to zero the AC6 unit after a period of time has elapsed and the unit has stabilised).

The AC6 unit has an inbuilt timer to switch the unit off after the period set by the timer function, If a button is pressed during the timing period the timer is reset to zero and will keep the unit on for a further period of time.

IMPORTANT SAFETY NOTE:

For removal of AC6 unit ensure that equalising valve is OPEN before CLOSING isolating valves on connection tubes. The AC6 unit and the connecting tubes can now be removed safely from subject measuring valve or device.

Removal or attachment of a single connection tube when isolating valves are open can result in automatic operation of the DSP technology™ sensor protection system and water will be ejected from the unconnected port. This mechanism is designed to protect the sensitive measuring sensor

For full functionality refer to menu system and features below.

5. Menu system

The AC6 has been designed with 5 menus for ease of use. Within each menu there are a series of functions which can be easily accessed and edited using the up, down, left and right keys.

Supplied with your AC6 is a 'Quick start guide' which shows the layout of each menu.

Main Menu	Display Menu	Units Menu	Advanced Menu	Damping Menu
Select Valve	Flow/ Pressure	Pressure	DP Cutoff	Update time
Valve Position	Multi display	Flow	Flow alerts	Sample time
Design Flow	Pressure	Temperature	Back Light timer	
Target Flow	Flow		Auto off timer	
Pipe size	Pressure Scope		View size as	
User Kvs	About			

Press menu button twice for language options. Language options apply to menus and help screens only.

The menu system is accessed using a single press of the menu button. Each menu can then be selected by using left or right arrow keys ◀▶ When the correct menu is shown on the screen use the up and down arrow keys ▲▼ to select the correct function which is then accepted using the tick button. ✓

Menu functions that require a numeric value to be added use a system which is best described using the following example:

Example- Setting the design flow to 1.05 l/s.

Menu selects the menu option,

◀ selects the **MAIN** menu

▼, ▼ moves the cursor down to the design flow option.

✓ accepts the design flow option

▲ will change the value of the first column to 1

▶ selects the next column

▼ selects a decimal point

▶ Selects the next column

- ▶ Selects the next column
- ▲,▲,▲,▲,▲, changes the digit to 5
- ✓ Accepts the selected value of 1.05
- X Returns to the main **DISPLAY**

To enter a negative number use the ZERO key before any number is added.
 To enter a decimal point, use the down arrow when the zero digit is showing. (See example above)

6. Display Options

The Display menu has six functions-

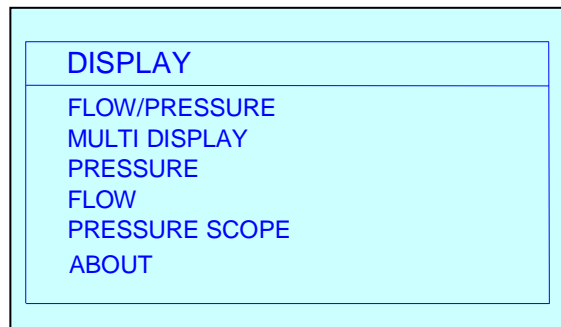

Flow/Pressure display

The Flow/Pressure display is the default display for the AC6 and is designed for most general commissioning purposes.

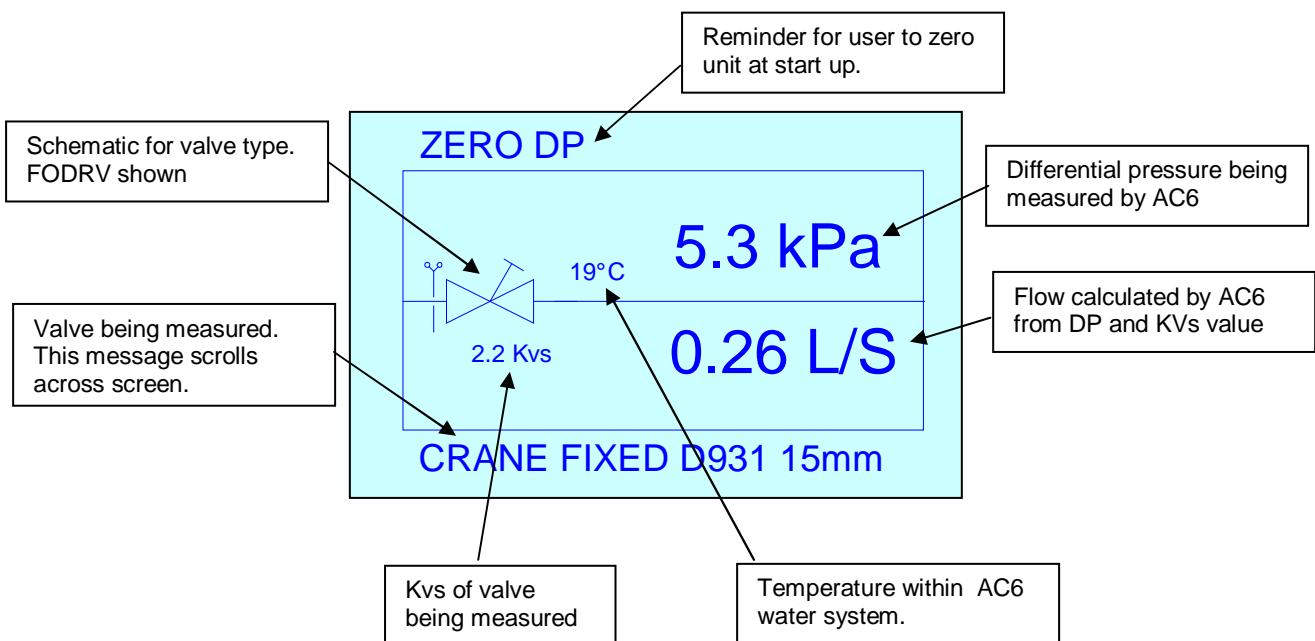

The flow and dp are displayed in large text for ease of use. The schematic valve and valve description are also maintained.

The type of valve selected (Fixed or variable) is shown as a schematic symbol with handwheel and kvs data in accordance with the selected valve.

The differential pressure and flow are displayed and continuously updated according to the signals received from the valve being measured.

Multi Display

For commissioning engineers wishing to carry out commissioning using design and target flow the Multi display can be selected.

The Multi display is the most appropriate when variable orifice valves are used.

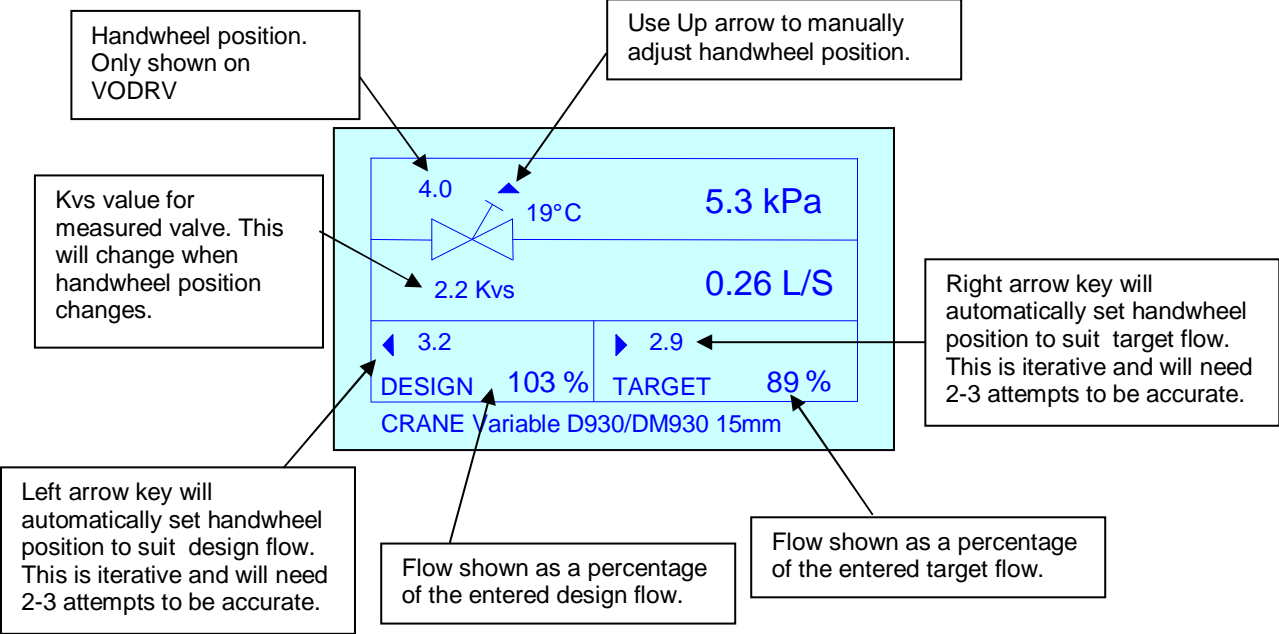

Design flow and target flow are displayed. If the values for these parameters are set to zero then a series of dashes are displayed.

When variable orifice balancing valves are selected and a design and target flow have been entered the Comdronic AC6 unit automatically uses the predictive handwheel position and displays this above the design or target flow in their respective boxes on the display. When the valve has been adjusted to the predicted position use the left or right arrow navigation button to adjust the handwheel setting. Note: The design flow and the target flow could be different values so it is important to use the correct navigation button.

The predictive process is iterative due to the unknown valve authority in the circuit so it will be necessary to use this feature more than once.

The measuring valve selected is described in the scrolling bar at the base of the screen.

Pressure display

The Differential pressure is displayed in large text. This screen is useful for users wishing to use the AC6 unit as a simple manometer.



Flow display

The flow is displayed in large text. The flow is derived from the differential pressure and the Kvs value from the selected valve. The Kvs value is also displayed for reference at the bottom of the screen.



Pressure scope

This display takes the form of an oscilloscope. The purpose of this screen is to allow the user to evaluate the nature of the signal being read from the selected valve. The stream of data gives a good indication of the stability of the system.

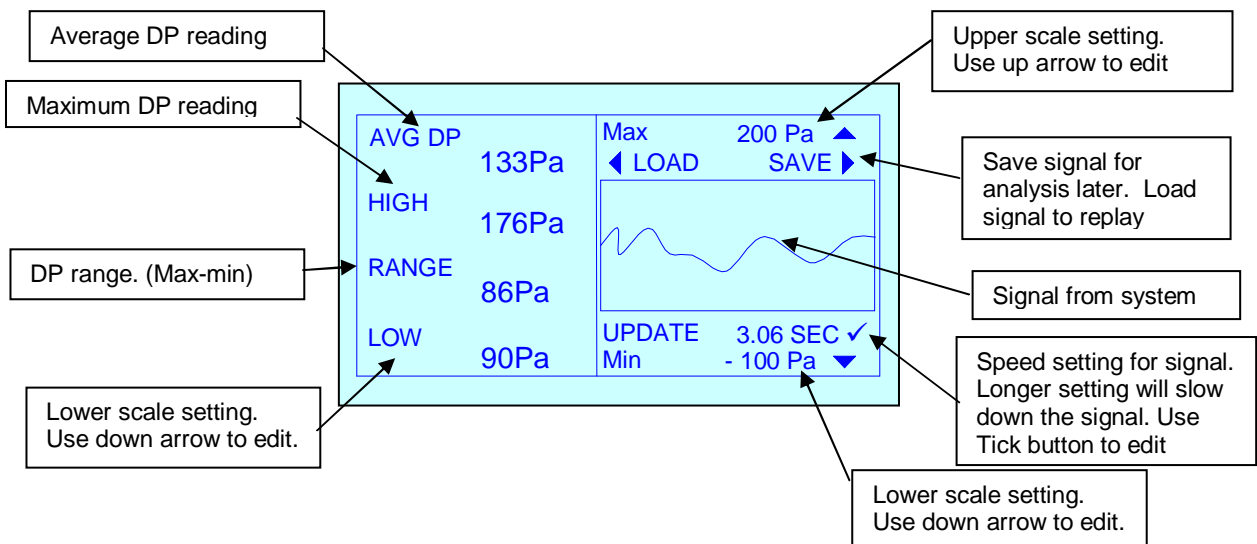

In order to view the pressure readings from the device being measured it will be necessary to set the scope scales above and below the average reading. The average reading is displayed and the high scale can be set using the up navigation arrow.

When the value has been edited use the Tick button to accept.

The low scale is set in the same way using the down navigation button. Use tick button to accept.

Note: The upper scale is best set by adding the average reading to the range reading. The lower scale is best calculated from the average reading minus the range reading.

Adherence to a set-up in this way will give the best display of system stability.

To increase the clarity of the display use the tick button to access the update time function which increase or decrease the speed of the scope. This feature can be used to increase the detail of the signal or reduce it to show a smoother average signal. A small sample of the signal can be saved to any one of eight memory locations by using the right navigation button.

The sample can be recalled and shown on screen by using the left navigation button.

About

The about screen gives the brand and the serial number of the unit.



'Main' menu

Within the MAIN menu there are 7 functions

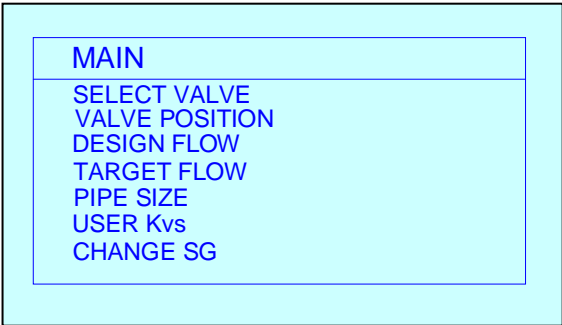

Select valve

The database of valves can be accessed using the navigation buttons.

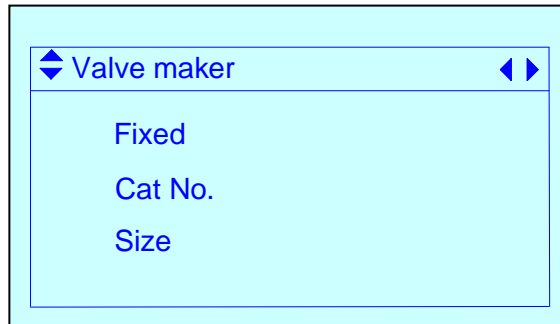

Important: Select all items on screen before using tick button to accept.

To select the manufacturer use the right or left navigation keys.

To select the type of valve, cat no. and size use the up and down navigation buttons followed by left and right keys for individual selections.

With the correct manufacturer, valve type, valve cat no. and size use the tick button to select.

Valve position

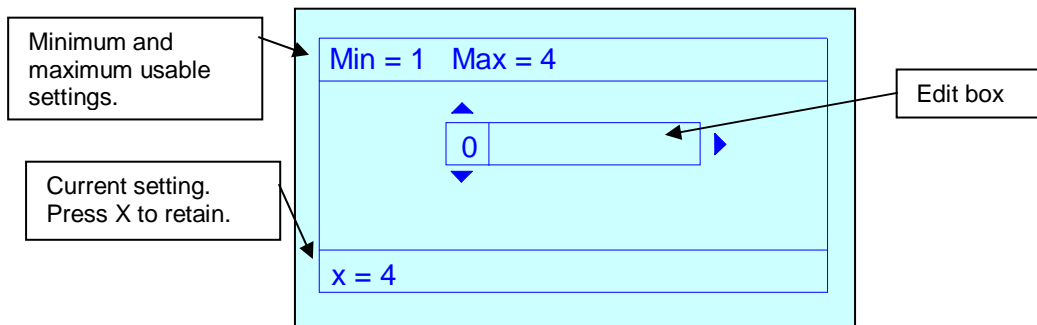

The handwheel position for variable orifice valves is required so that the correct value of Kvs is used for the derivation of the flowrate.

This screen allows the position to be edited.

The display shows the maximum and minimum recommended positions for the valve. The minimum position shown ensures that the valve maintains reasonable accuracy.

Design flow

The design flow for the selected valve can be edited in this screen.

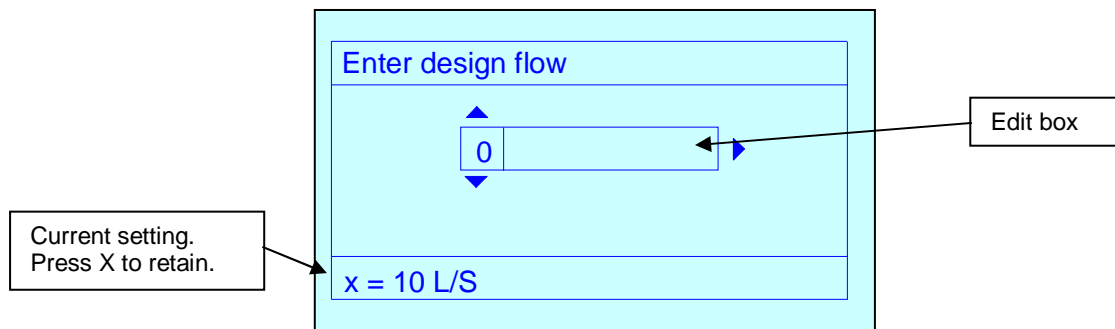

When a value is entered, the actual flow will be calculated as a percentage of the design flow and will be displayed on the Multi display in the design flow box.

Design flow can be entered in any of the units selectable in the units screen.

Target flow

The target flow for the selected valve can be edited in this screen.

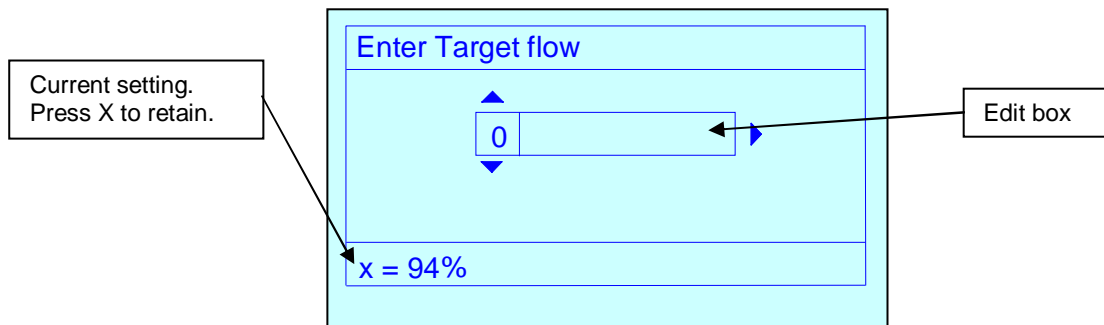

When a value is entered it will be displayed on the main display in the target flow box.

Target flow must be entered as a percentage and is generally derived when carrying out proportional balancing. Typically, the value used will be the same as the calculated design flow percentage on the index circuit.

Balancing to 100% target on subsequent valves will ensure that valves adjacent to the index valve are balanced. **(See Glossary)**

User Kvs

This screen allows for the user to enter the Kvs value of a measuring device that is not held in the database of valves. Typically this would be a fixed orifice device. When a Kvs is required for a variable orifice device then the Kvs is required for **each position** of the handwheel.

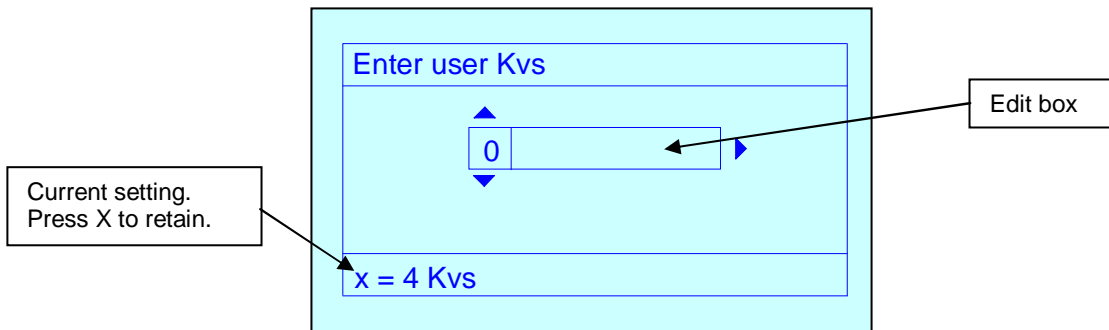

Contact Comdronic for advice on upgrading valve database.

Change SG (Specific gravity)

This screen allows the user to enter the value of the SG. Typically this would be used when glycol or other antifreeze agents are used in the system.

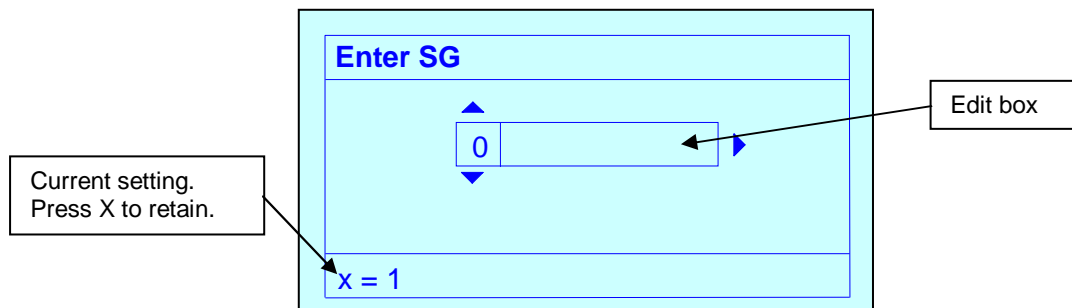

It will be necessary to derive the SG from a look up chart – see Chapter 13.

Note: When an SG is set to a value other than 1.0 an advisory note is added to the top of the display

Quick Valve.

This display allows the user to save the data from the current valve to a project.

To use this feature press the Tick button whilst viewing any of the display screens.

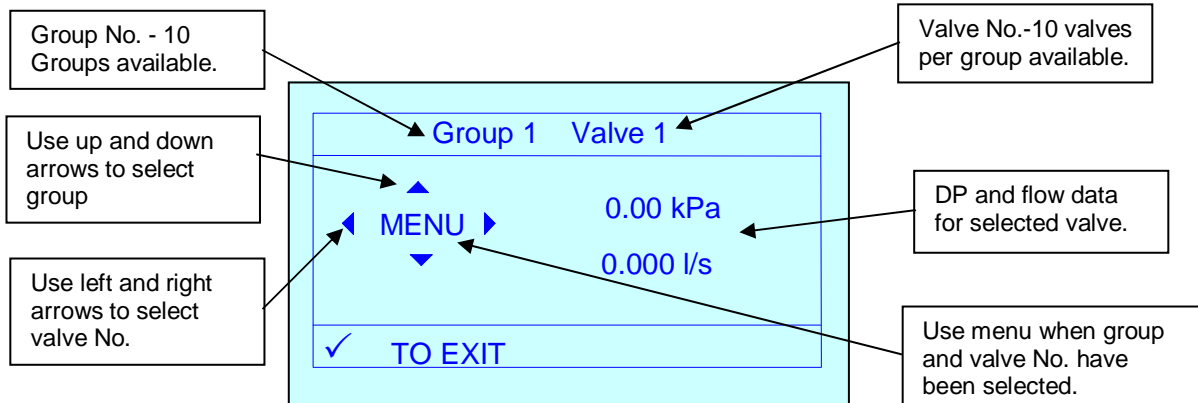

The project can be made up from up to ten groups of valves each with ten valves. The group number can be selected using the UP and DOWN arrows and the valve number can be selected using the LEFT and RIGHT arrow keys.

The menu button gives the user the save or delete options. If the screen is black then a valve is already in the location, however If the screen is white then it is possible to load a valve to this location.

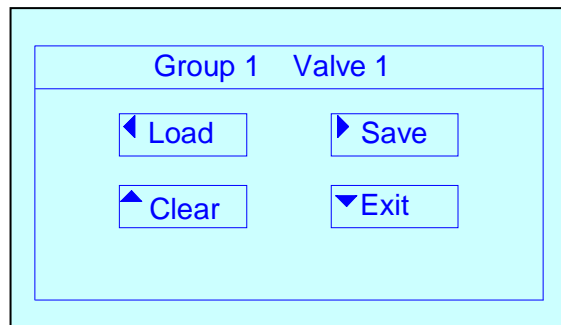

Using the SAVE command will overwrite the location with the current valve data. The quick valve feature allows the user to save the selected valve to a memory location which is quickly accessible without having to use the 'Select Valve' option. The purpose of this is to reduce time when commissioning a system with say 3 different types of valve. The 3 types of valve could be saved to the quick valve memory including the design flow designated for that valve. When recalled the valve will be loaded to the unit including the design flow.

Follow the on screen instructions to save the current selection or delete the existing saved valve.

An additional use for this feature is the ability for the user to save the commissioned data for up to 100 valves on a project for reference later prior to producing a commissioning report.

When the data for the selected valve has been saved the following screen appears.

The example shown is for a VODRV – all other valve types have a simpler screen.

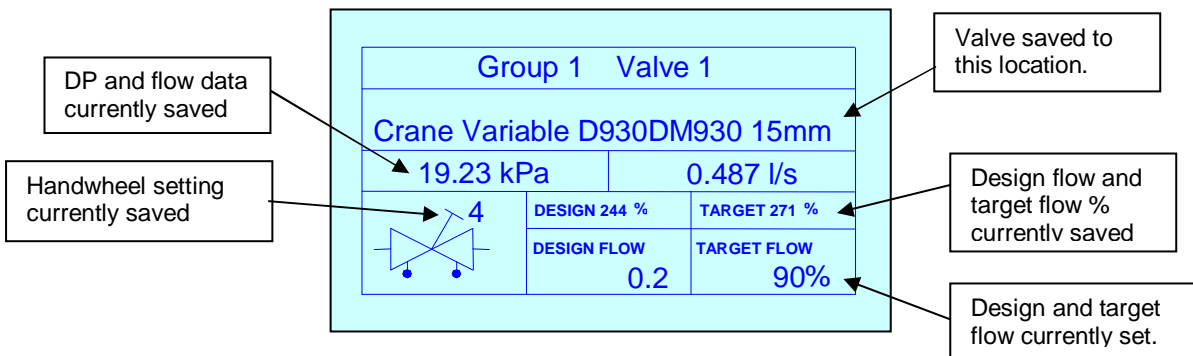

‘Advanced’ menu

dP cut-off

This screen allows the user to edit the value of cutoff. Typically this value would be in the order of 30 kPa. This value prevents the dp reading from fluctuating due to ambient influences and very small levels of electrical noise when reading zero. A DP cutoff is typical for digital devices.

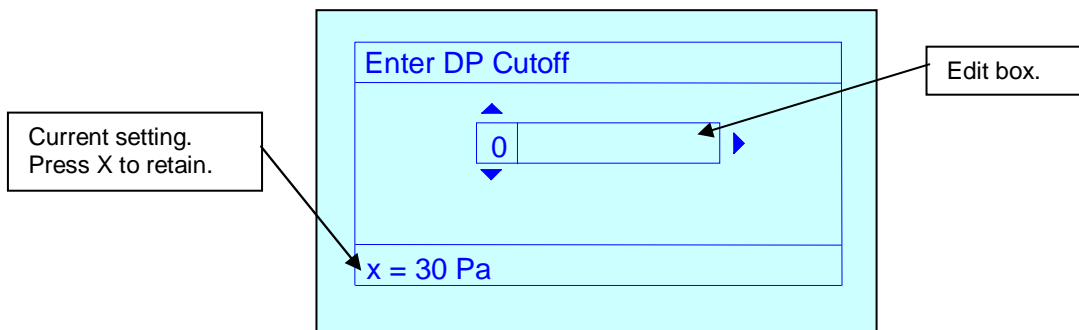

The pressure reading will not change until at least the cutoff value is reached.

When this value is reached the cutoff is de-activated and all changes in reading are stabilised by the averaging system.

Flow alerts

Flow alerts can be switched between off and on. The alerts relate to the flow in the selected valve, high flow means that the measured flow is outside the range normally expected in the valve. Similarly, if the flow is low then it is below the expected value.

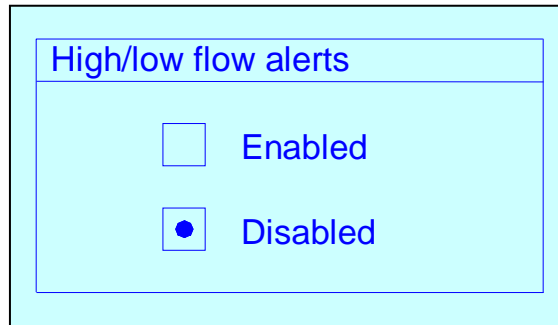

The screenshot shows a menu titled "High/low flow alerts" with two radio button options: "Enabled" (unchecked) and "Disabled" (checked).

When working on unstable or systems that have little regulation the alerts can sometimes impede commissioning operations.

Light timer

The light timer sets the period of time that the light remains on. Pressing any key will re-activate it.

Setting the light to a short time will preserve battery life.

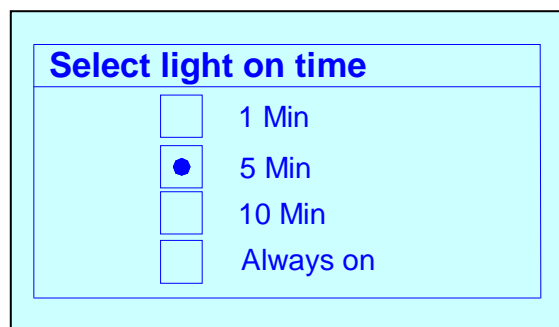

The screenshot shows a menu titled "Select light on time" with four radio button options: "1 Min" (unchecked), "5 Min" (checked), "10 Min" (unchecked), and "Always on" (unchecked).

Use up and down arrow buttons to select option followed by tick button to accept.

Auto off timer

The Auto off timer sets the time the unit remains on.
Setting the time to a short time will preserve battery life.

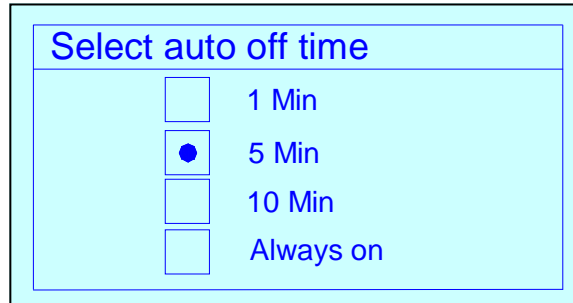

The screenshot shows a menu titled "Select auto off time" with four radio button options: "1 Min", "5 Min", "10 Min", and "Always on". The "5 Min" option is selected, indicated by a blue dot inside the radio button.

Use up and down arrow buttons to select option followed by tick button to accept.

View size as

This screen allows the user to select the preferred units for selecting valve size. The default unit is metric. (mm)

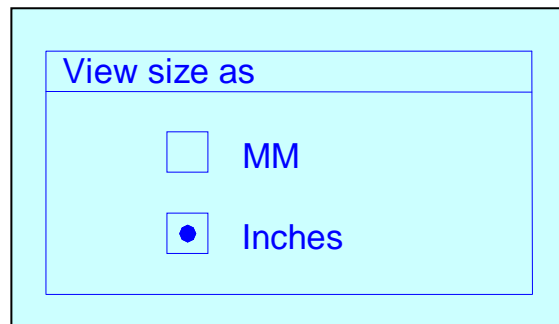

The screenshot shows a menu titled "View size as" with two radio button options: "MM" and "Inches". The "Inches" option is selected, indicated by a blue dot inside the radio button.

Use up and down arrow buttons to select option followed by tick button to accept.

DAMPING MENU

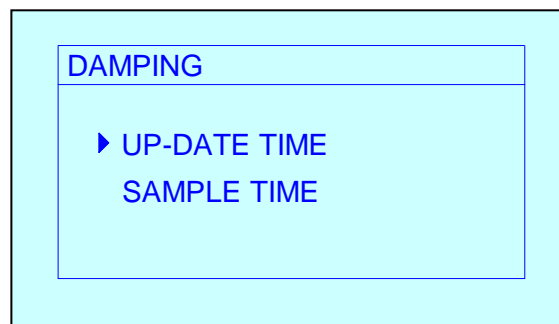

The screenshot shows a menu titled "DAMPING" with two sub-menu options: "UP-DATE TIME" and "SAMPLE TIME". Both options are preceded by a right-pointing arrowhead.

Use up and down arrow buttons to select option followed by tick button to accept.

Up-date time

This screen allows the user to change the apparent sensitivity of the AC6.

This value is set by the user to increase or decrease the time delay between each screen update. If the time is short then the screen updates often. A long update time will give the appearance of a steadier reading.

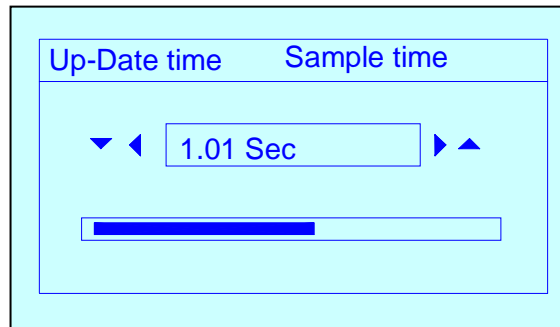

Use up and down arrow buttons for coarse adjustment and left / right arrow buttons for fine adjustment. Typical setting would be 1 second.

Note: Increase this time on an unstable system.

Sample time

This screen allows the user to change the period over which the readings are averaged.

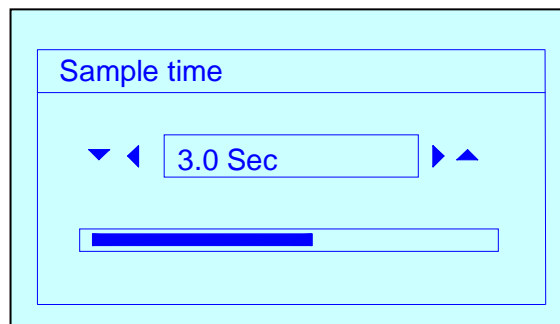

Use up and down arrow buttons for coarse adjustment and left / right arrow buttons for fine adjustment. Typical setting would be 3 seconds.

This value can be edited up to 11 seconds and it represents the base time over which the readings are taken for the rolling average system.

A typical time of 3 seconds allows a large number of readings to be taken before the mean calculation is made.

The averaging system continues to use 3 seconds of measured values but on a rolling average basis.

Increasing the sample time will make the screen appear to update slower but with a more stable reading.

The sample time is also used as a time base when using the pressure chart display to study the pressure signal from the device being measured.

UNITS MENU

This screen gives the user the option of selecting the preferred units for display on the AC6.

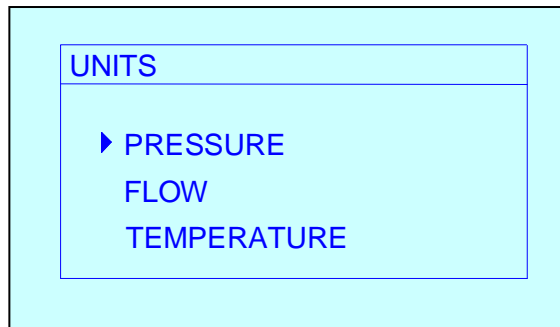

Use up and down arrow buttons to select option followed by tick button to accept.

Note: The AC6 firmware uses Pascals and L/s for all internal calculations. The AC6 will convert other units to this standard for processing before converting back for display purposes.

Pressure

This screen will display differential pressure units. The menu right button will change the displayed units to **kPa, PSI, BAR, mm H₂O, cm H₂O Pascals, Inches water gauge, Feet head**

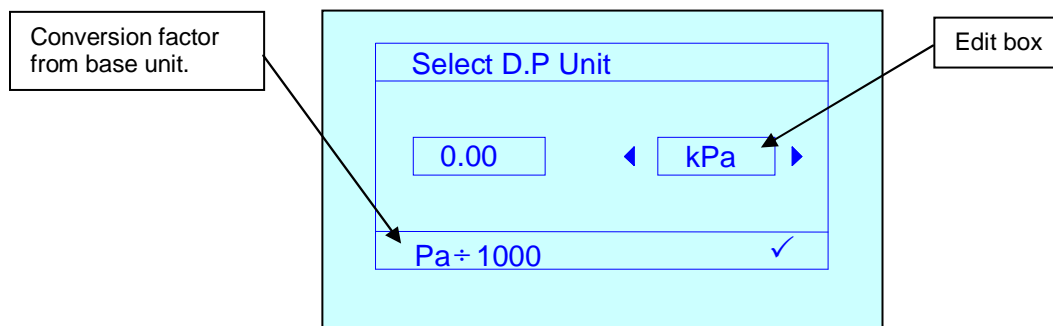

Use up and down arrow buttons to select option followed by tick button to accept.

Flow

This screen will display volume flow units. The Menu right button will change the units through **L/s**, **L/M**, **L/hr**, **USGPM**, **UKGPM**, **M³/h**, **M³/m**, **M³/s**

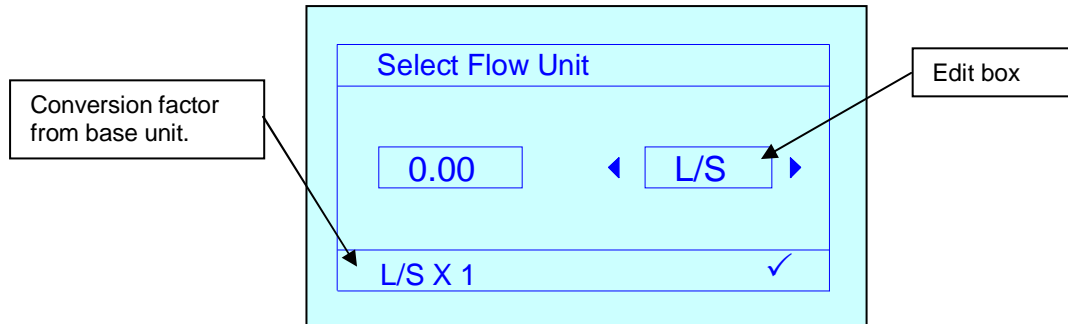

Use up and down arrow buttons to select option followed by tick button to accept.

Note: Velocity units are available (Metres per second and Feet per second)

In order to display the current velocity in the system being measured it will be necessary to select the following:

- 1 - Select valve being measured (Main menu)
- 2 – Enter pipesize (Main menu)
- 3 – Select velocity units (Units menu)

Temperature

This screen will display temperature. **Degrees Celsius, Fahrenheit.**

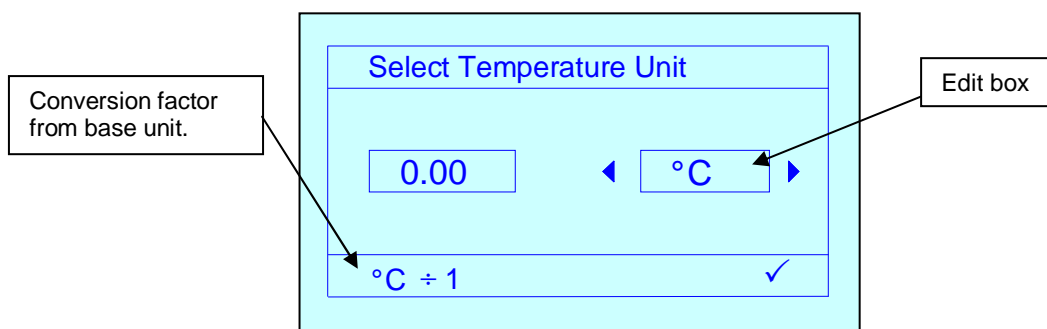

Use up and down arrow buttons to select option followed by tick button to accept.

7. AUTOMATIC BALANCING VALVES

Unique to the AC6 is the ability to display variables associated with automatic balancing valves.

The AC6 firmware has been arranged to display data for with three types of automatic flow controller:

- 1 – Fixed internally adjustable cartridge type.
- 2 – Fixed cartridge type.
- 3 – Externally adjustable types.

The displays associated with this type of valve are automatically selected when the valve maker and model etc are selected.

For full information it is recommended that the MULTI DISPLAY is selected as shown below.

The valve shown is externally adjustable type.

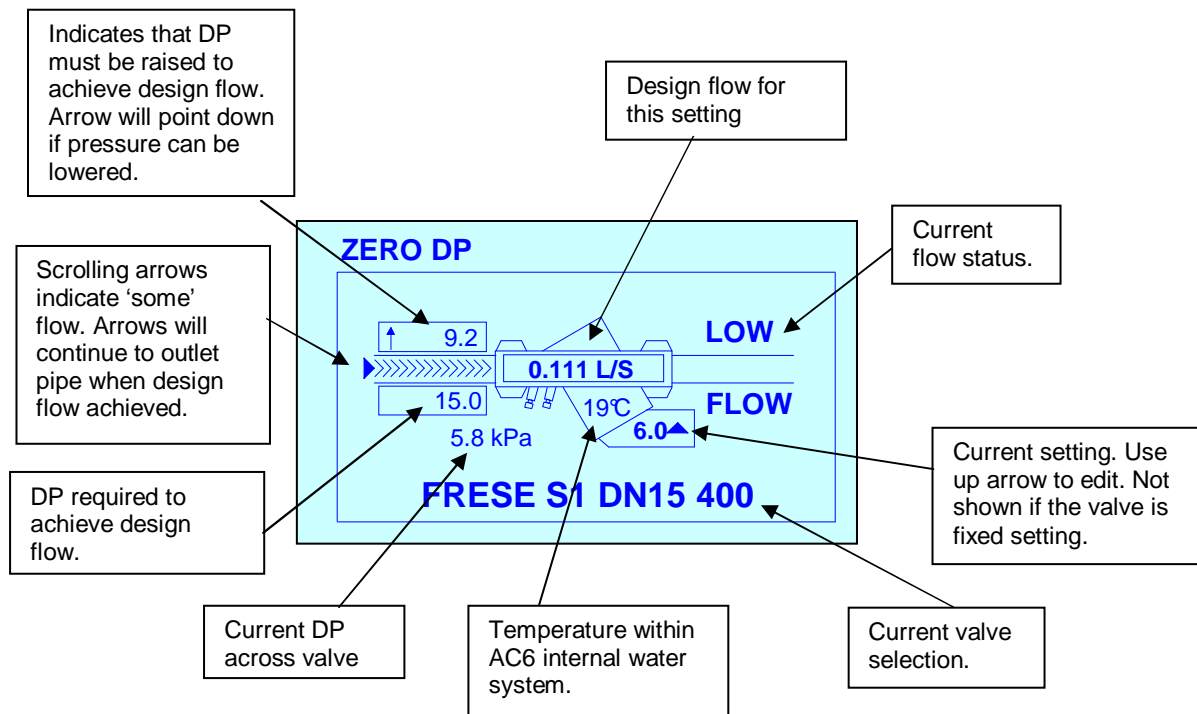

If a valve is selected that is not adjustable either internally or externally then the setting tab is not shown on the valve image.

The design flow for any automatic flow controller will be achieved if the differential pressure across the valve reaches the design value. Each automatic balancing valve and each setting for the valve will possibly have a different design DP. The AC6 database holds the design DP for each valve/setting.

When the AC6 is adjusted to select the correct valve/setting the design flow is displayed within the valve image. If the DP is not sufficient to create correct flow conditions the box above the inlet pipe to the valve will display an up arrow and a value indicating that the DP

will need to be increased to achieve the design flow. The value displayed is the design DP less the actual DP.

In the event of the actual DP being higher than the design DP then the box will display a down arrow and a DP value that suggests a reduction in actual DP. – On an Index circuit this would suggest that the pump speed could be decreased to achieve the correct DP value.

If the design flow is not met, then the message LOW FLOW will be displayed. If the design flow is met then the message will be FLOW OK.

For a simplified display the Flow/pressure display is recommended.

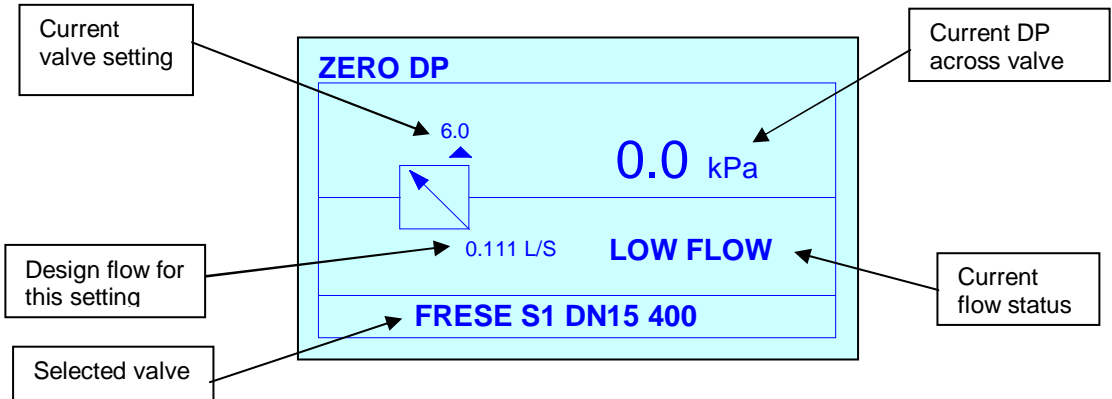

Quick valve (When using automatic flow controllers)

The procedure for using quick valve is the same as if traditional balancing valves are in use. Press the tick button whilst any of the display screens are in use and the user will be prompted to select group and valve No.

The screen showing saved data is shown below.

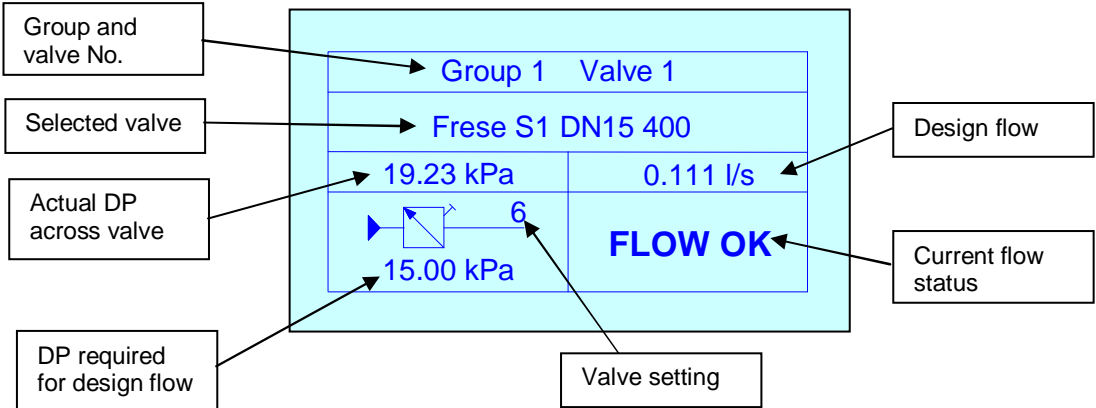

The above example shows that the actual DP is greater than the design DP therefore the flow status is displayed as FLOW OK.

8. Spares and Accessories

Toolbelt – Ideal for the new ‘Working at Height Legislation’ .

Pocketed and padded High visibility bib (BS EN 471) for carrying AC6, mobile phone, pens and notebooks etc.

Replacement and Additional Hoses – up to 3 metres in length.

Industry Standard Insertion Test Points.

Mechseal Adaptors.

9. Technical Specification

Measurement Accuracy

Differential pressure– better than 100 Pascals or 1% whichever is the greatest.

Measurement Range

0.1 kPa to 250 kPa

0 to 95 deg c

Effective Operating Time

20 hours with standard Alkaline PP3 battery

Sensor protection.

Unique DSP technology™ ensures that the sensor is protected against accidental overpressure. The system maintains a differential pressure of below approx 3.5 bar even in the event of a single pressure connection being removed. In this situation one side of the sensor is at atmospheric pressure whilst the other is at full system static pressure- a situation which could cause sensor failure if not protected against.

Calibration.

Standard factory calibration is carried out in controlled conditions using calibrators traceable to National Standards. It is recommended that AC6 units are re-calibrated at least once per year. If the units are used directly after chemical cleaning and flushing the re-calibration period should be less.

Valve Database

The AC6 can be programmed with up to 1300 valves which are held on the factory database.

In general, two database lists are programmed into the AC6. The European list is the most extensive with the US list being less extensive.

Valve data can be added to the AC6 in a number of different ways – Contact your supplier for more details.

User Interface

Software for the Comdronic AC6 unit has been designed around simple text files which are supplied on CD rom. Users wishing to edit the files can simply remove the MMC card from the AC6 unit and using a suitable read/write device and text editor can make the desired changes. Typically, users might wish to add valves or devices not held on the database or, modify the list of valves displayed on the AC6 unit to allow quicker access to preferred valves.

The most appropriate programme for editing the text files associated with the Comdronic AC6 unit is Windows® notepad. Contact Comdronic Ltd for details.

10. Statement of Conformity

This is to certify that the COMDRONIC COMMISSIONING UNIT

Manufactured in the EU has been calibrated in accordance with standards traceable to national standards and conforms to the published specification. It is CE marked in accordance with the relevant EC directives.

11. Contacting Us

For all enquiries, troubleshooting, technical and sales contact us at any of the following:-

e-mail: enquiries@comdronic.com

Tel +44 (0) 1473 462036

Fax: +44 (0) 1473 462036

Address: 48 Larchcroft Road, Ipswich, Suffolk, IP1 6AN

Visit our website at www.comdronic.com

12. Glossary of Terms

Automatic Balancing valve

A valve designed to deliver a fixed flowrate when the differential pressure across the valve has reached the required value. Any further increase in the differential pressure will not significantly change the flowrate.

Authority

The ratio of the pressure drop across the valve when fully open to that of the circuit including the valve.

Calibration

The relationship between the sensor of a measuring instrument and the displayed output. All sensors have small variations and these are recorded and held within the instrument so that accurate readings are displayed.

Design flow

The intended flow through a circuit or a system as determined by the design engineer.

DSP Technology™

A unique design concept for the protection of sensitive differential pressure sensors within measuring instruments. The technology allows the use of a sensor which is most appropriate to the range of pressures being measured.

DP Cutoff

A small pressure offset programmed into a pressure instrument to prevent the display fluctuating at, or around the zero position. Sensors at zero position are susceptible to electrical noise and other transients. A typical value of 20-30 Pascals will prevent the display moving from zero when no differential pressure is being measured.

Differential pressure

The difference in pressure existing between the upstream and downstream pressure tapping points. Often the word 'Signal' is used to describe this pressure in measuring devices.

Flow alerts

An advisory message to alert the user that the signal measured is consistent with a flowrate either above or below that recommended for the device.

Fixed orifice

The part of a flow measurement device which induces a difference in pressure for flow measurement purposes. The orifice will be of fixed dimensions and geometry.

Kvs

The flow of water through a fixed or variable flow measurement device at a temperature of between 5 and 40 degrees C and measured in cubic metres per hour that will induce a differential pressure or signal of 1 bar

Mechseal adaptor

Adaptor conforming to a specification suitable for connection to double seal safety test valve.

MMC card

Multimedia card used within digital instruments for the storage of data. This media also allows for ease of editing when using proprietary card readers.

Target flow

The flow being measured in a reference valve, such as the index circuit. The subsequent valves to be adjusted would be set to deliver this same flow which is normally expressed as a percentage of the design flow for the reference valve.

Test point

A hole in the side of a flow measurement device, the internal end of which is flush with the internal surface of the flow measurement device. There are normally 2 test points with each flow measurement device fitted either side of the differential inducing orifice.

Specific Gravity

The relationship of the mass of the fluid in the system with that of water. If a fluid has 30% glycol mix then at 10 degrees C the Specific gravity will be 1.043 (See chart)

Update time

This is the rate at which the display screen of the measuring instrument is refreshed. A high refresh rate will reduce the number of readings taken before the screen changes resulting in an apparent less stable display.

Sample time

This is the time over which the instrument carries out a rolling average. An increase in sample time will give the appearance of a more stable reading, although, slower to change.

Variable orifice device

The part of a flow measurement device which induces a difference in pressure for flow measurement purposes. The orifice will be of variable dimensions and geometry.

BS7350

Insertion probe.

Adaptor conforming to a specification suitable for connection to insertion type test points. Generally these are 3.3mm diameter. This type of test point and adaptor are considered to be industry standard.

13. Glycol/water SG chart



SPECIFIC GRAVITY OF WATER / GLYCOL MIXTURES

Temperature	% Glycol additive										
Deg C	0	10	20	30	40	50	60	70	80	90	100
80			0.991	1.003	1.017	1.026	1.036	1.046	1.054	1.062	1.068
70		0.990	1.000	1.010	1.023	1.034	1.042	1.053	1.062	1.069	1.075
60		0.995	1.007	1.017	1.030	1.041	1.050	1.060	1.070	1.076	1.083
50		1.000	1.013	1.013	1.035	1.048	1.057	1.067	1.077	1.084	1.090
40	0.990	1.004	1.018	1.029	1.042	1.054	1.064	1.074	1.085	1.091	1.098
30	0.996	1.007	1.022	1.034	1.047	1.059	1.070	1.080	1.092	1.099	1.105
20	0.999	1.010	1.026	1.038	1.052	1.065	1.076	1.088	1.099	1.106	1.114
10	1.000	1.013	1.028	1.042	1.056	1.070	1.082	1.094	1.105	1.113	1.120
0	1.000	1.015	1.029	1.045	1.061	1.075	1.088	1.100	1.112	1.120	1.128
-10				1.048	1.065	1.079	1.092	1.107	1.118	1.127	1.135
-20					1.068	1.083	1.097	1.113	1.124	1.133	1.136
-30						1.087	1.100	1.118	1.128	1.137	1.137
-40							1.102	1.122	1.133	1.138	1.138

E & OE

14. INDEX

	PAGE NO.
Accuracy	22,
Alerts	3,5,15,24,
Antifreeze	2,12
Auto off timer	3,5,16
Backlight timer	3,5,15
Balancing	1,7,11,20,21,24
Battery	2,3,15,16,22
Battery life	13,16
Bluetooth	2,
Calibration	22,24
Connection tubes	3,4,5
Context sensitive Help	3,
Damping	16,5
Database	1,10,12,20,22,23
Defaults	3,
Design Flow	9,3,5,7,11,13,20,21,24,25,14
Differential pressure	1,4,7,8,19,21,23
DP cutoff	3,5,14,24
DSP Technology	1,4,5,22
Equalising Valve	25,26
Firmware	18,20,9,
Flow	3,4,5,6,7,8,9,10,11,13,15,19,20,21,24,25
FODRV	6,
Glycol	1,12,25,26
Handwheel	6,7,10,12,14
Health and Safety	1,2
Insertion Probes	2,22
Kvs	2,5,7,98,10,12,2,4,6,
Manometer	8,
MMC	23,24
Multi Display	5,7,11,20,24,6
Pipe size	5,9
PPE	2,
Predictive handwheel	7,
Pressure	1,2,3,4,5,6,7,8,9,14,18,20,21,22,24,25
Pressure scope	5,6,8
Quick valve	13,21
Sample	3,5,9,16,17,18,25
Save	8,9,13,14,21
Signal	7,8,9,18,24
Software	1,2,23
Specific Gravity	3,13,26,27
Target Flow	3,5,7,11,25,9,14
Temperature	2,3,4,5,19,24,26,6,18,20
Text files	23,
Transducer	2,
Update	2,3,5,7,8,9,17,18,25
View size	5,9,13,16
VODRV	14,7
Zeroing	4,