

Ultrasonic Flowmeter for Liquids



FLUXUS F601

MS-DOS, Excel, Windows are registered trademarks of Microsoft Corporation.
FLUXUS is a registered trademark of FLEXIM GmbH.

FLEXIM GmbH
Wolfener Strasse 36
12681 Berlin
Germany

Tel.: +49 (30) 936 67 660

Fax: +49 (30) 936 67 680

E-mail: flexim@flexim.de

www.flexim.com

User manual for

FLUXUS F601

UMFLUXUS_F6V4-0EN, 2010-05-03

Firmware V5.xx

Copyright (©) FLEXIM GmbH 2010

Subject to change without notification.

Die Sprache, in der die Anzeigen auf dem Messumformer erscheinen, kann eingestellt werden (siehe Abschnitt 8.5).

The transmitter can be operated in the language of your choice (see section 8.5).

Il est possible de sélectionner la langue utilisée par le transmetteur à l'écran (voir section 8.5).

El caudalímetro puede ser manejado en el idioma de su elección (ver sección 8.5).



Table of Contents

1	Introduction	9
1.1	Regarding this Manual	9
1.2	Safety Instructions.....	9
1.3	Warranty.....	10
2	Handling	11
2.1	First Inspection.....	11
2.2	General Precautions	11
2.3	Cleaning	11
2.4	Storage.....	11
3	Transmitter	12
3.1	Measurement principle.....	12
3.2	Serial number	12
3.3	Description of the Transmitter	13
3.4	Keyboard	14
4	Selection of the Measuring Point	16
4.1	Acoustic Penetration	16
4.2	Undisturbed Flow Profile	18
5	Installation and Power Supply	21
5.1	Installation	21
5.2	Connections	22
5.3	Power Supply	28
5.4	Status Indication.....	30
6	Mounting the Transducers	31
6.1	Mounting the Transducers with Fastening Shoes and Chains.....	31
7	Installation of the Temperature Probes (Optional)	35
7.1	Mounting the Temperature Probes	35
8	Start-up	37
8.1	Switching on/off.....	37
8.2	Connection of the Transducers	37
8.3	Displays.....	38
8.4	HotCodes	40
8.5	Language Selection	41

9	Basic Measurement	42
9.1	Input of the Pipe Parameters	42
9.2	Input of the Medium Parameters	45
9.3	Other Parameters	47
9.4	Selection of the Channels	47
9.5	Defining the Number of Sound Paths	48
9.6	Transducer Distance	49
9.7	Start of the Measurement	52
9.8	Detection of the Flow Direction	52
9.9	Stopping the Measurement	52
10	Displaying the Measured Values	53
10.1	Selection of the Physical Quantity and of the Unit of Measurement	53
10.2	Toggling between the channels	54
10.3	Adjustment of the Display	55
10.4	Status Line	55
10.5	Transducer distance	56
11	Advanced Measuring Functions	57
11.1	Damping Factor	57
11.2	Totalizers	57
11.3	Upper Limit of the Flow Velocity	59
11.4	Cut-off Flow	60
11.5	Uncorrected Flow Velocity	61
11.6	Measurement of Transient Processes (FastFood Mode)	62
11.7	Calculation Channels	63
11.8	Change of the Limit for the Inner Pipe Diameter	66
12	Storing and Output of Measured Values	67
12.1	Data Logger	68
12.2	Output of the Measured Values	69
12.3	Deleting the Measured Values	75
12.4	Settings for the Data Logger	75
12.5	Available Data Logger Memory	77
13	Working with Parameter Records	78
13.1	Introduction	78
13.2	Storing of a Parameter Record	78
13.3	Loading of a Parameter Record	78
13.4	Deleting Parameter Records	79

14	Libraries	80
14.1	Partitioning of the Coefficient Memory	80
14.2	Input of Material/Medium Properties without the Extended Library.....	82
14.3	Extended Library	83
14.4	Deleting a User Defined Material/Medium.....	88
14.5	Arrangement of the Material/Medium Scroll List	88
15	Settings	91
15.1	Time and Date	91
15.2	Dialogs and Menus	92
15.3	Measurement Settings	95
15.4	Setting the Contrast	97
15.5	Instrument Information	97
16	SuperUser-Mode	98
16.1	Activating/Deactivating	98
16.2	Transducer Parameters	98
16.3	Defining the Flow Parameters	99
16.4	Limit of the Signal Amplification	101
16.5	Upper Limit of the Sound Velocity	102
16.6	Number of Decimal Places of the Totalizers	103
16.7	Temperature-Based Heat Flow Cut-Off.....	104
16.8	Manual Reset of the Totalizers	104
16.9	Display of the Sum of the Totalizers	105
16.10	Display During the Measurement	105
17	Time-Programmable Measurement (Optional)	106
17.1	Activating/Deactivating	106
17.2	Input of the Start Time	106
17.3	Input of the Stop Time	107
17.4	Measurement Duration.....	108
17.5	Measuring in the Time-Programmable Measurement Mode	109
17.6	Storing Measured Values	111
17.7	Online Output	111
18	Wall Thickness Measurement (Optional)	112
18.1	Activation of the Wall Thickness Measurement.....	112
18.2	Parameter Input	113
18.3	Measurement	114

19	Heat Flow and Heat Quantity	118
19.1	Measuring Setup	118
19.2	Calculation of the Heat Flow and the Heat Quantity	118
19.3	Settings	119
19.4	Measurement	120
19.5	Steam in the Supply Line	121
20	Inputs	123
20.1	Assigning the Temperature Inputs to the Measuring Channels	123
20.2	Selection of the Temperature Probe	125
20.3	Assignment of Other Inputs to the Measuring Channels	125
20.4	Activation of the Inputs	126
20.5	Temperature Correction	127
21	Outputs	128
21.1	Installation of an Output	128
21.2	Error Value Delay	133
21.3	Activation of an Analog Output	134
21.4	Configuration of a Frequency Output as a Pulse Output	135
21.5	Activation of a Binary Output as a Pulse Output	136
21.6	Activation of a Binary Output as an Alarm Output	137
21.7	Behavior of the Alarm Outputs	140
21.8	Deactivating the Outputs	143
22	Troubleshooting	144
22.1	Problems with the Measurement	145
22.2	Selection of the Measuring Point	146
22.3	Maximum Acoustic Contact	147
22.4	Application Specific Problems	147
22.5	Large Deviations of the Measured Values	147
22.6	Problems with the Totalizers	148

Annex

A	Menu Structure	149
B	Technical Data	170
C	Reference	181
D	Certificates	186

1 Introduction

1.1 Regarding this Manual

This manual has been written for the personnel operating the ultrasonic flowmeter FLUX-US. It contains important information about the instrument, how to handle it correctly, and how to avoid damages.

Make sure you have read and understood this manual before using the instrument.

Read the safety Instructions carefully. Make sure you have read and understood this manual before using the instrument.

All reasonable effort has been made to ensure the correctness of the content of this user manual. However, If you find any erroneous information, please inform us. We will be grateful for any suggestions and comments regarding the concept and your experience working with the instrument.

This will ensure that we can further develop our products for the benefit of our customers and in the interest of technological progress. If you have any suggestions about improving the documentation and particularly this user manual, please let us know so that we can consider your comments for future reprints.

The contents of this user manual are subject to changes without prior notice. All rights reserved. No part of this manual may be reproduced in any form without FLEXIM's written permission.

1.2 Safety Instructions

The user manual contains instructions that are marked as follows:

Note!	This text contains important information about the use of the flowmeter.
--------------	--

Attention!	This text contains important instructions which should be observed to avoid damage or destruction of the flowmeter. Proceed with special caution!
-------------------	---

Observe these safety instructions!

1.3 Warranty

The FLUXUS flowmeter is guaranteed for the term and to the conditions specified in the sales contract provided the equipment has been used for the purpose for which it has been designed and operated according to the instructions given in this User Manual. Misuse of the FLUXUS will immediately revoke any warranty given or implied.

This includes:

- replacement of a component of FLUXUS with a component that was not approved by FLEXIM
- unsuitable or insufficient maintenance
- repair of FLUXUS by unauthorized personnel

FLEXIM assumes no responsibility for injury to the customer or third persons proximately caused by the material owing to defects in the product which were not predictable or for any indirect damages.

FLUXUS is a very reliable instrument. It is manufactured under strict quality control, using modern production techniques. If installed as recommended in an appropriate location, used cautiously and taken care of conscientiously, no troubles should appear.

If any problem appears which can not be solved with the help of this manual (see chapter 22), contact our sales office giving a precise description of the problem. Specify the type, serial number and firmware version of the flowmeter.

2 Handling

2.1 First Inspection

The flowmeter has already been tested thoroughly at the factory. At delivery, proceed to a visual control to make sure that no damage has occurred during transportation.

Check that the specifications of the flowmeter delivered correspond to the specifications given on the purchase order.

The type and the serial number of the transmitter are shown on the nameplate. The transducer type is printed on the transducers.

2.2 General Precautions

FLUXUS is a precision measuring instrument and must be handled with care. To obtain good measurement results and not damage the instrument, it is important that great attention is paid to the instructions given in this user manual, particularly to the following points:

- Protect the transmitter from shocks.
- Keep the transducers clean. Manipulate the transducer cables with caution. Avoid excessive cable bend.
- Make sure to work under correct ambient and operating temperatures. The ambient temperature must be within the operating temperature range of the transmitter and the transducers (see annex B, section Technical Data).
- Use a correct external power supply when the transmitter is not used with the battery.
- Handle the battery charging unit and the battery correctly (see section 5.3).
- The power supply unit and the battery charging unit are not protected against moisture. Use them in dry rooms only.
- Observe the degree of protection (see annex B, section Technical Data).

2.3 Cleaning

- Clean the transmitter with a soft cloth. Do not use detergents.
- Remove traces of the coupling compound from the transducers with a soft paper towel.

2.4 Storage

- Wipe the transducers clean of traces of the coupling compound.
- After the measurement, always put the transmitter and its accessories into the corresponding compartments of the transport case.
- Avoid excessive cable bends, especially when closing the cover of the transport case.
- Observe the notes on the storage of the battery (see section 5.3).

3 Transmitter

3.1 Measurement principle

The flow of the medium is measured by ultrasonic signals using the transit time difference method.

Ultrasonic signals are emitted by a transducer installed on one side of the pipe, reflected on the opposite side and finally received by a second transducer. The signals are emitted alternatively in and against the flow direction.

As the medium in which the signals propagate is flowing, their transit time in flow direction is shorter than against the flow direction.

The transit time difference Δt is measured, allowing to determine the average flow velocity on the propagation path of the ultrasonic signals. A flow profile correction is then performed to obtain the area average of the flow velocity, which is proportional to the volumetric flow rate.

The received ultrasonic signals are tested for their usefulness for the measurement and the plausibility of the measured values is evaluated. The complete measuring procedure is controlled by the integrated microprocessors. Disturbance signals are eliminated.

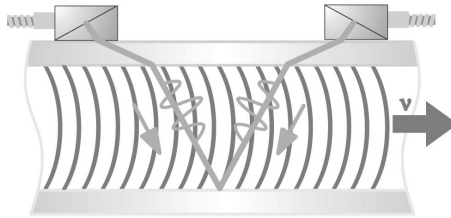

Fig. 3.1: Path of the ultrasonic signal

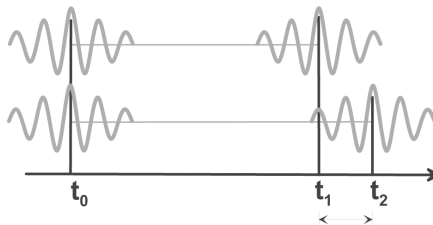

Fig. 3.2: Transit time difference Δt

3.2 Serial number

The type and the serial number are shown on the nameplate of the transmitter. When contacting FLEXIM, always have both numbers and the number of the firmware version at hand (see section 15.5).

3.3 Description of the Transmitter

3.3.1 Design

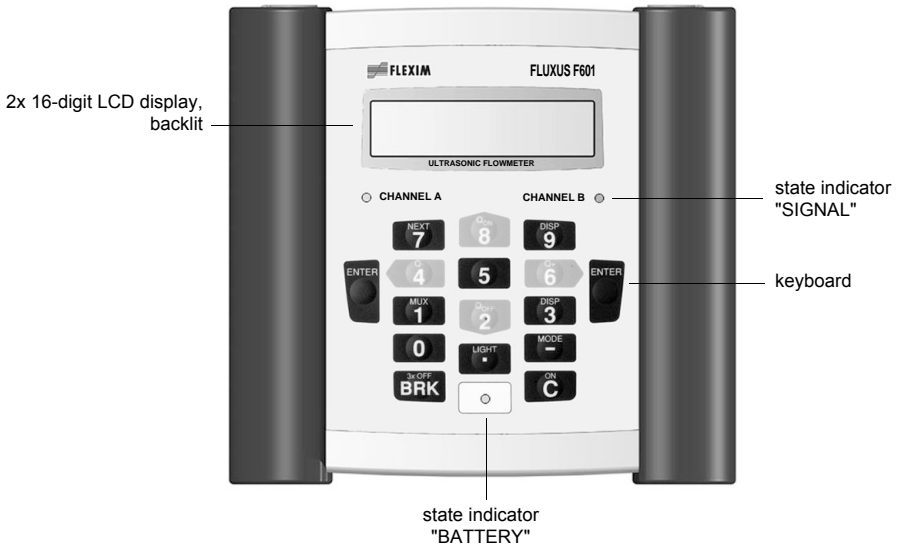

Fig. 3.3: Command panel

A handle is mounted to the back side of the transmitter (see Fig. 3.4). It can also be used as support. The aperture in the support plate is used to fix the transmitter to a pipe (see section 5.1.3).



Fig. 3.4: Back side

3.4 Keyboard

The keyboard consists of three function keys ENTER, BRK and C, the status indicator BATTERY and ten numerical keys.

Several keys have double functions. They can be used for entering data and for navigating through scroll lists.





The arrow-shaped keys , ,  and  are used as cursor keys in the selection mode and for entering digits and letters in the input mode.

Table 3.1: General functions

C	switching on the transmitter
LIGHT	switching on/off the backlight of the display
ENTER	confirmation of selection or of entered value
BRK + C + ENTER	RESET: Press these three keys simultaneously to correct a malfunction. The reset has the same effect as restarting the transmitter. Stored data are not affected.
BRK	interruption of the measurement and selection of the main menu Be careful not to stop a current measurement by inadvertently pressing key BRK!
BRK	switching off the transmitter by pressing key BRK three times

Table 3.2: Navigation





BRK	selection of the main menu
 	scroll to the left/right through a scroll list
 	scroll upwards/downwards through a scroll list
ENTER	confirmation of the selected menu item

Table 3.3: Input of digits





 ... 	input of the digit shown on the key
	sign for the input of negative values
	decimal marker
C	Delete values. After the value has been deleted, the previous value will be displayed.
ENTER	confirmation of input

Table 3.4: Input of text











 	positioning of the cursor
	changing the currently selected character to an "A"
	changing the currently selected character to a "Z"
	changing between small and capital letters
 	selection of the precedent/next ASCII character
	deleting the character and inserting a blank
 ... 	Automatic scrolling up or down through the limited ASCII character set. The character changes every second. The scrolling is stopped by pressing any other key.
ENTER	finishing editing

Table 3.5: Cold start

BRK + C	<p>INIT (cold start): Most parameters and settings are reset to the factory default values. Stored data is not affected.</p> <p>Keep the two keys pressed while switching the transmitter on until the main menu is displayed.</p> <p>A cold start during operation is executed as follows:</p> <ul style="list-style-type: none"> • Press the keys BRK, C and ENTER simultaneously. A RESET is executed. • Release key ENTER only. Keep the keys BRK and C pressed until the main menu is displayed.
---------	---

4 Selection of the Measuring Point

The correct selection of the measuring point is crucial for achieving reliable measurement results and a high measurement accuracy.

A measurement on a pipe is possible if

- the ultrasound propagates with a sufficiently high amplitude (see section 4.1)
- the flow profile is fully developed (see section 4.2)

The correct selection of the measuring point and thus, the correct transducer positioning guarantees that the sound signal will be received under optimum conditions and evaluated correctly.

Due to the variety of applications and the different factors that influence the measurement, there is no standard solution for the transducer positioning. The correct position of the transducers is influenced by the following factors:

- diameter, material, lining, wall thickness and form of the pipe
- medium
- gas bubbles in the medium

Avoid measuring points in the vicinity of deformations and defects of the pipe and in the vicinity of welds.

Avoid locations with deposit formation in the pipe.

The ambient temperature must be within the operating temperature range of the transducers (see annex B, section Technical Data).

Select the location of the transmitter within cable reach of the measuring point.

The ambient temperature at the location must be within the operating temperature range of the transmitter (see annex B, section Technical Data).

If the measuring point is within an explosive atmosphere, the danger zone and gases that may be present must be determined. The transducers and the transmitter must be appropriate for these conditions.

4.1 Acoustic Penetration

The pipe must be acoustically penetrable at the measuring point. The acoustic penetration is reached when pipe and medium do not attenuate the sound signal so strongly that it is completely absorbed before reaching the second transducer.

The attenuation in the pipe and in the medium depends on:

- kinematic viscosity of the medium
- proportion of gas bubbles and solids in the medium
- deposits on the inner pipe wall
- pipe material

The following requirements must be met at the measuring point:

- the pipe is always filled completely
- no material deposits in the pipe
- no bubbles accumulate

Note!

Even bubble-free media can form gas bubbles when the medium expands, e.g. before pumps and after great cross-section extensions.

Observe the notes in Table 4.1.

Table 4.1: Recommended mounting position



<p>horizontal pipe</p> <p>Select a measuring point where the transducers can be mounted on the side of the pipe, allowing the sound waves to propagate in the pipe horizontally. Thus, solid deposits on the bottom of the pipe or gas bubbles in the pipe's upper part will not influence the propagation of the signal.</p>	
<p>correct :</p> 	<p>disadvantageous:</p> 
<p>vertical pipe</p> <p>Select the measuring point at a pipe location where the medium flows upward. The pipe must be completely filled.</p>	
<p>correct :</p> 	<p>disadvantageous:</p> 

Table 4.1: Recommended mounting position

4.2 Undisturbed Flow Profile

Some flow elements (elbows, slide valves, valves, control valves, pumps, reducers, diffusers, etc.) distort the flow profile in their vicinity. The axisymmetrical flow profile needed for correct measurement is no longer given. A careful selection of the measuring point helps to reduce the impact of disturbance sources.

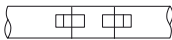
It is most important that the measuring point is chosen at a sufficient distance from any disturbance sources. Only then it can be assumed that the flow profile in the pipe is fully developed. However, measuring results can be obtained even if the recommended distance to disturbance sources can not be observed for practical reasons.

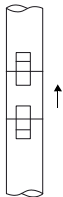
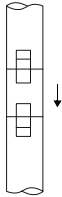
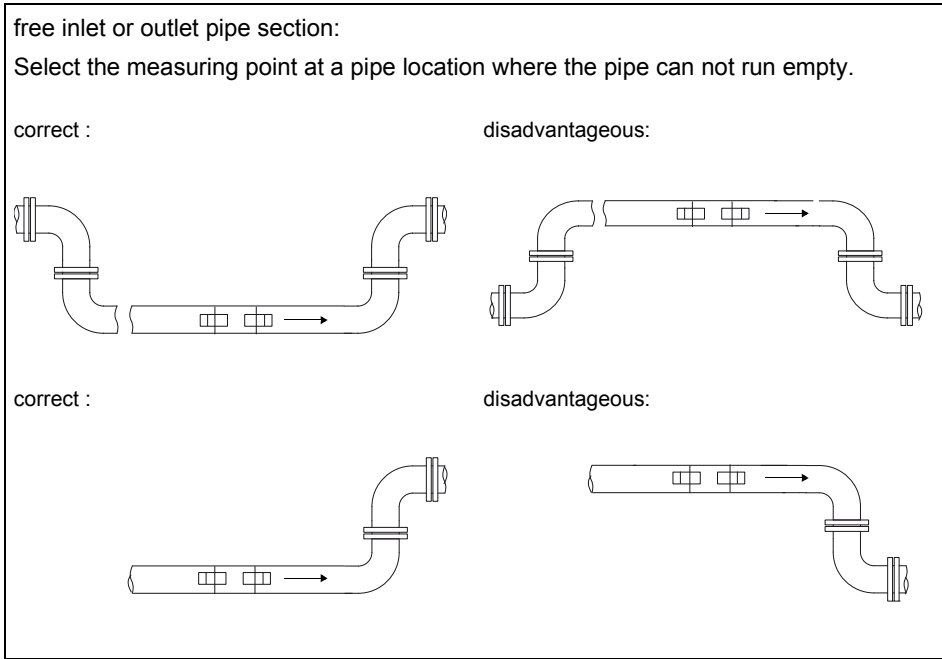
Recommended straight inlet and outlet pipe lengths for different types of flow disturbance sources are shown in the examples in Table 4.2.

Table 4.2: Recommended distance from disturbance sources

D = nominal pipe diameter at the measuring point, l = recommended distance



disturbance source: 90° elbow	
supply line: $l \geq 10 D$	return line: $l \geq 5 D$
	
disturbance source: 2x 90° elbows on same level	
supply line: $l \geq 25 D$	return line: $l \geq 5 D$
	
disturbance source: 2x 90° elbows on different level	
supply line: $l \geq 40 D$	return line: $l \geq 5 D$
	
disturbance source: T piece	
supply line: $l \geq 50 D$	return line: $l \geq 10 D$
	

Table 4.2: Recommended distance from disturbance sources
D = nominal pipe diameter at the measuring point, l = recommended distance

disturbance source: diffuser supply line: $l \geq 30 D$		return line: $l \geq 5 D$	
			
disturbance source: valve supply line: $l \geq 40 D$		return line: $l \geq 10 D$	
			
disturbance source: reducer supply line: $l \geq 10 D$		return line: $l \geq 5 D$	
			
disturbance source: pump supply line: $l \geq 50 D$			
			

5 Installation and Power Supply

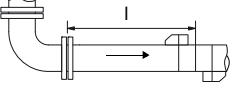
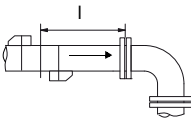
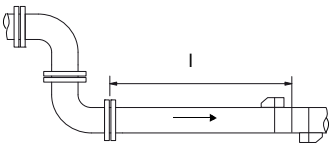
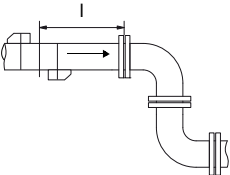
5.1 Installation

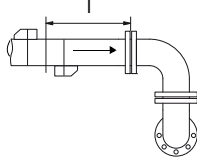
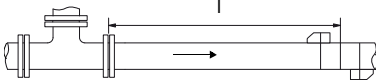
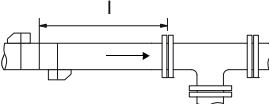
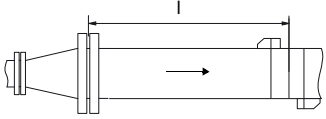
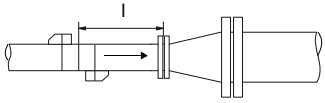
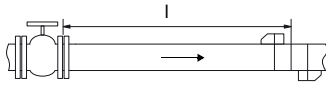
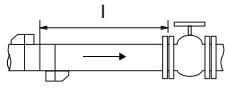
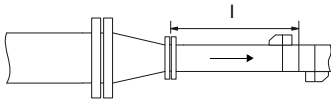
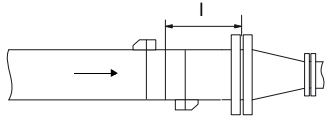
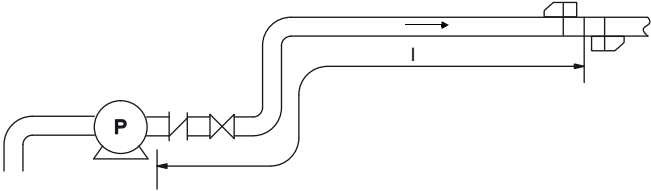
5.1.1 Placement

Push the support back to the stop of the support plate.

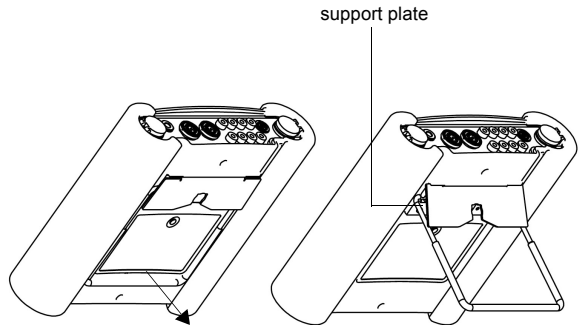

Fig. 5.1: Placement of the Transmitter

5.1.2 Hanging

Press both ends of the handle outwards and pass them past the support plate. Turn the handle upwards.

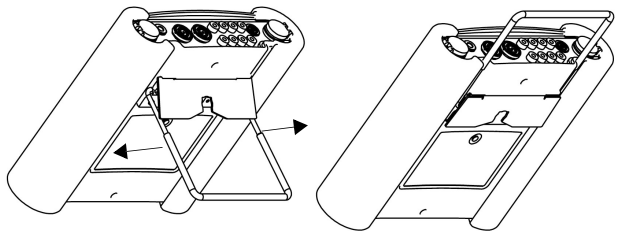

Fig. 5.2: Hanging of the transmitter

5.1.3 Fixing on the Pipe

Attention! When the transmitter is fixed to the pipe, the pipe temperature must not exceed the operating temperature of the transmitter.

Fix the tension belt to the pipe with the button. Tighten the belt by means of the ratchet. Insert the button into the aperture of the support plate on the back side of the transmitter.

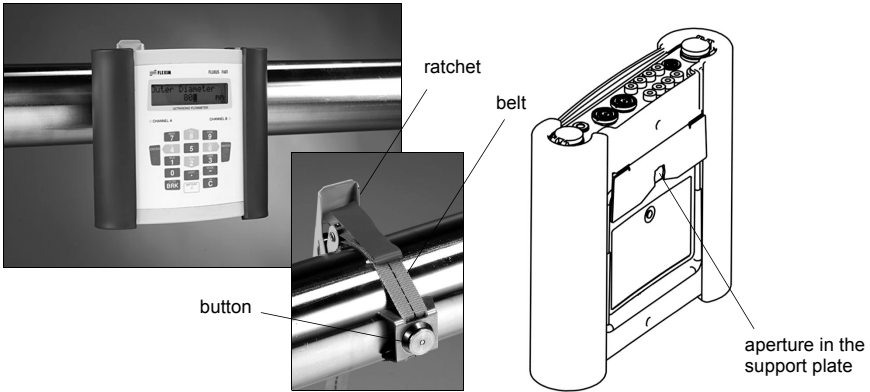

Fig. 5.3: Fastening the transmitter to the pipe

5.2 Connections

The connections are on the upper side of the transmitter.

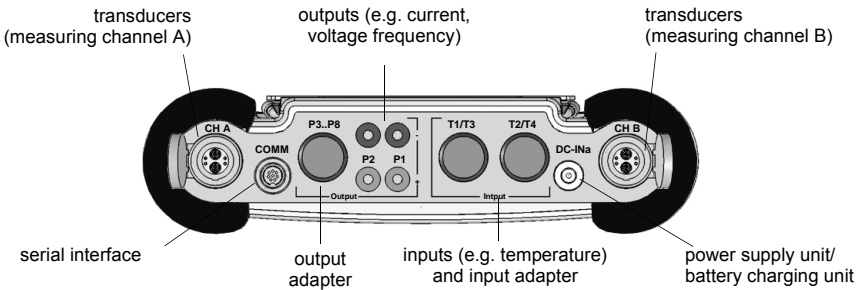
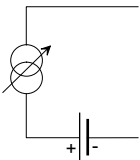
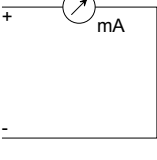
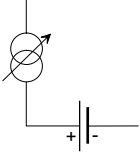
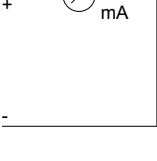
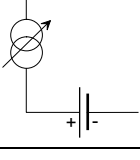
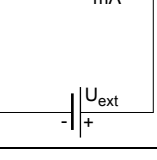
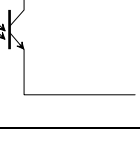
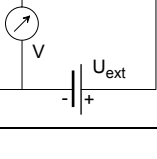
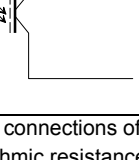
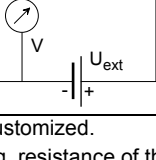

Fig. 5.4: Connections of the transmitter

5.2.1 Outputs

Circuits

Tabelle 5.1: Circuits of the outputs

output	transmitter internal circuit	connection	external circuit	remark
active current loop		Px+ Px-		$R_{\text{ext}} < 200 \Omega$
passive current loop (semi-passive design, used as active current loop)		Px+ Px-		$R_{\text{ext}} < 50 \Omega$ e.g. for local connection of a multimeter
passive current loop (semi-passive design)		Px+ Px-		$U_{\text{ext}} = 4 \dots 16 \text{ V}$ $U_{\text{ext}} > 0.021 \text{ A} \cdot R_{\text{ext}} [\Omega] + 4 \text{ V}$ example: $U_{\text{ext}} = 12 \text{ V}$; $R_{\text{ext}} = 0 \dots 380 \Omega$
frequency output		Px+ Px-		$U_{\text{ext}} = 5 \dots 24 \text{ V}$ $R_c [\text{k}\Omega] = U_{\text{ext}} / I_c [\text{mA}]$ $I_c = 1 \dots 4 \text{ mA}$
binary output (optorelay)		Px+ Px-		$U_{\text{ext}} \leq 26 \text{ V}$ $I_c \leq 100 \text{ mA}$

The number, type and connections of the outputs are customized.

R_{ext} is the sum of all ohmic resistances in the circuit (e.g. resistance of the conductors, resistance of the amperemeter/voltmeter).

Adapter

The number of outputs can be increased to max. 8 by connecting the output adapter (optional).

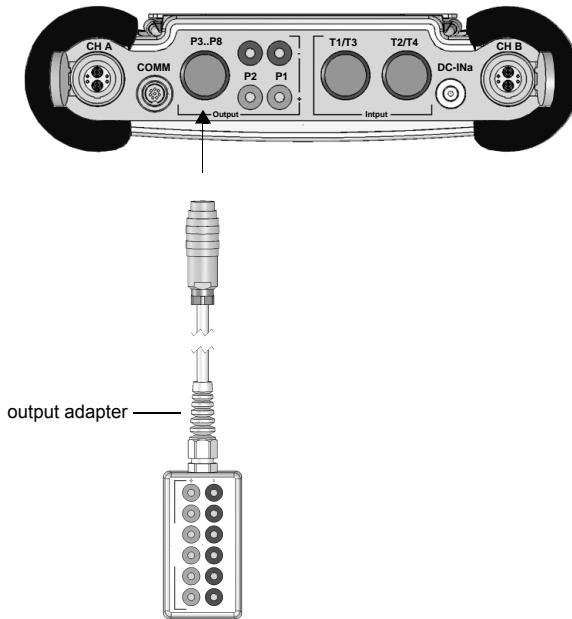

Fig. 5.5: Connection of the output adapter

5.2.2 Inputs

Temperature Input

Temperature probes Pt100/Pt1000 (4-wire) can be connected to the inputs of the transmitter (optional).

For the assignment and the activation of the temperature inputs see chapter 20.

Passive Current Input

An active current source or a passive current source with an external power supply can be connected to a passive current input.

Table 5.2: Connection of an active current source

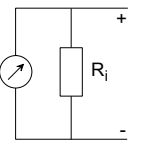
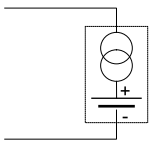
input	transmitter		external circuits	note
	internal circuits	connection		
passive current input		+ -		max. permanent over-current: 40 mA

If the polarity of the current source is inverted, only the sign of the measured current will change.

Table 5.3: Connection of a passive current source

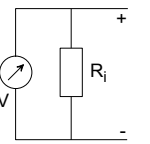
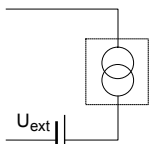
input	transmitter		external circuits	note
	internal circuits	connection		
passive current input		+ -		short circuit current: max. 40 mA

An external voltage source U_{ext} is necessary. It must provide a current of min. 20 mA and

- supply sufficient power for the energy requirements of the passive current source and
- cover the voltage drop at the input resistor (1 V at 20 mA) and
- cover all other voltage drops (e.g. cable resistance) in the circuit

example: A passive current source (e.g. a pressure sensor) is to be connected to a passive current input.

Technical data of the pressure sensor:

$$U_S = 11...30 \text{ V DC}$$

$$I_a = 4...20 \text{ mA } (I_{a \text{ max}} = 22 \text{ mA})$$

U_{ext} required for the operation of the passive pressure sensor is:

$$\begin{aligned} U_{\text{ext min}} &= U_{S \text{ min}} + I_{a \text{ max}} \cdot R_i + I_{a \text{ max}} \cdot R_c \\ &= 11 \text{ V} + 22 \text{ mA} \cdot 50 \Omega + 20 \text{ mA} \cdot 2 \Omega \\ &= 12.14 \text{ V} \end{aligned}$$

$$\begin{aligned} U_{\text{ext max}} &= U_{S \text{ max}} \\ &= 30 \text{ V} \end{aligned}$$

U_S - operating voltage of the pressure sensor

I_a - output current

R_i - input resistance

R_c - cable resistance

Adapter

The number of temperature inputs can be increased to max. 4 by means of 2 input adapters (optional).

If the transmitter has voltage or current inputs, the adapter for voltage or current inputs will be used.

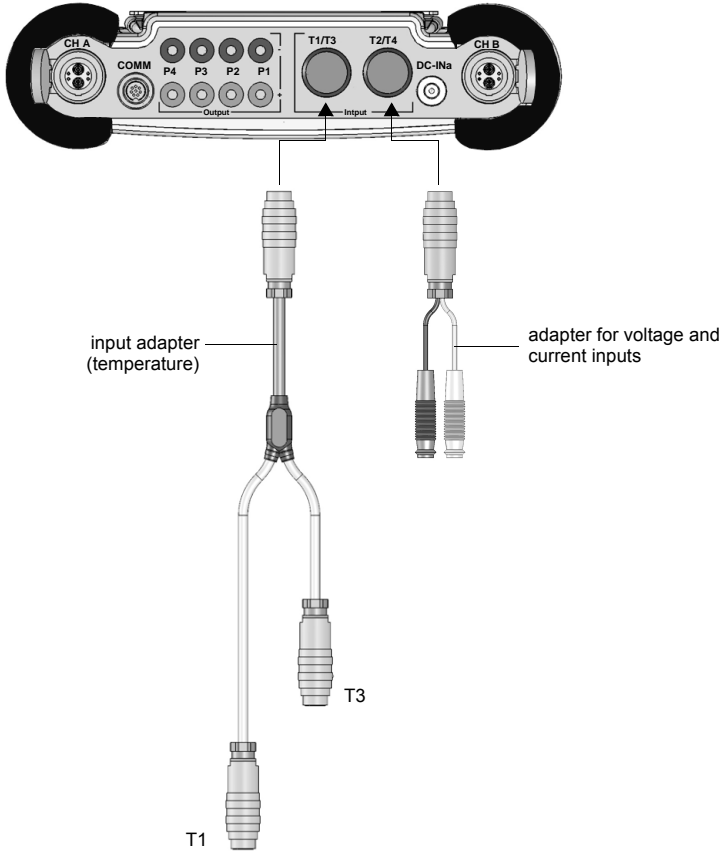

Fig. 5.6: Connection of the input adapter

5.3 Power Supply

The transmitter can be operated with a power supply unit or with the battery.

5.3.1 Operation with Power Supply Unit

Connect the power supply unit to the socket on the upper side of the transmitter (see Fig. 5.4).

Attention!

- Use only the supplied power supply unit.
- The power supply is not protected against moisture. Use it only in dry rooms.
- The voltage indicated on the power supply unit must not be exceeded.
- Do not connect a defective power supply unit to the transmitter.

5.3.2 Operation with Battery

The transmitter has a Li-Ion battery and can be operated independently of the power adapter.

At delivery, the battery is charged approx. 30 %. The battery does not need to be fully charged before it is used for the first time.

The charge state of the battery can be displayed during the measurement (see section 10.3) and in the program branch `Special Funct.:`

```
Special Funct.  ⬆
Battery status
```

Select `Special Funct.\Battery status`. Press ENTER.

```
■■■■ 30%-
      Cy: 1
```

The current charge state of the battery is displayed (here: 30 %).

The minus sign "-" indicates that the transmitter is in battery mode and is being discharged.

The number of cycles the battery has passed is displayed after `Cy:`.

A cycle corresponds to a charging and discharging process. The life time of the battery can be derived by means of this value.

If `RELEARN` is displayed in the lower line and a question mark "?" is displayed in front of the current charge state, a relearn cycle should be started (see section Maintenance on the following page).

This message will be displayed if the battery is almost empty.

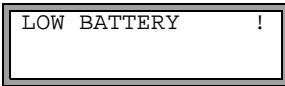

The capacity is sufficient for the display and storing of the current parameter record. A measurement is impossible.

Charge Battery

Connect the power supply unit to the transmitter. Switch on the transmitter. The charging starts. The LED "BATTERY" flashes green while charging. The max. charging time is approx. 5 h.

During the charging, the ambient temperature should be in the range 0...60 °C.

A measurement can be made during the charging. Charging will be stopped automatically when the battery is fully charged. The LED "BATTERY" will light green.

Storing the Battery

The battery remains in the transmitter. After storage, the transmitter can immediately be operated with the battery.

- charge state: > 30 %
- storing temperature: 12...25 °C

Maintenance (Relearn Cycle)

The accuracy of the displayed value for the charge state is improved by executing a relearn cycle. The ambient temperature during a relearn cycle should be in the range 12...30 °C.

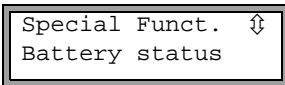

Select Special Funct.\Battery status. Press ENTER.

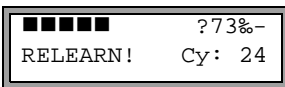

The charge state of the battery is displayed (here: 73 %).

The "?" and RELEARN indicate that the displayed charge state is not reliable. A relearn cycle is recommended.

Proceed as follows for a relearn cycle:

- Charge the battery completely. The LED "BATTERY" lights green when charging is finished.
- Discharge the battery completely: Remove the power supply unit from the transmitter. To deactivate the automatic power off during discharging, start a measurement. Discharging takes min. 14 h. The LED "BATTERY" will flash red afterwards.

5.3.3 Automatic Power off

In the battery mode, the transmitter has an automatic power off. The transmitter will be switched off if

- no measurement is being made and no key is pressed in 10 min or
- the battery is empty

POWER OFF IN 10 s

This message will be displayed before the transmitter is switched off automatically. A countdown with an acoustic signal is started.

The countdown can be stopped by pressing any key.

■ LOW BATTERY WHILE POWER OFF

If this message is displayed when the transmitter is switched on, the transmitter has been switched off automatically due to a too low charge state.

5.4 Status Indication

Table 5.4: LED "SIGNAL"

LED off	transmitter offline
LED lights green	signal quality of the measuring channel sufficient for a measurement
LED lights red	signal quality of the measuring channel not sufficient for a measurement

Table 5.5: LED "BATTERY"

LED flashes green	battery is being charged
LED lights green	battery is charged
LED off	charge state of the battery > 10 %
LED flashes red	charge state of the battery < 10 %

Note!	If the LED "BATTERY" flashes red/green, the power supply has an internal error. Contact FLEXIM for more information.
--------------	--

6 Mounting the Transducers

Before you start this chapter, read and follow the instruction in chapter 9.

The transducers will be fixed to the pipe by means of the supplied transducer mounting fixture.

Rust, paint or other deposits on the pipe will absorb the sound signal. A good acoustic contact between pipe and transducers is obtained as follows:

- Clean the pipe at the selected measuring point:
- Remove rust or loose paint. An existing paint layer on the pipe should be smoothed for a better measuring result.
- Use coupling foil or apply a bead of acoustic coupling compound along the center line onto the contact surface of the transducers.
- Observe that there must be no air pockets between the transducer contact surface and the pipe wall.
- Make sure that the transducer mounting fixture applies the necessary pressure on the transducers.

The transducers are mounted in such way that the engravings on the transducers form an arrow (see Fig. 6.1). The transducer cables show then in opposite directions.

For the determination of the flow direction with the help of the arrow see section 9.8.

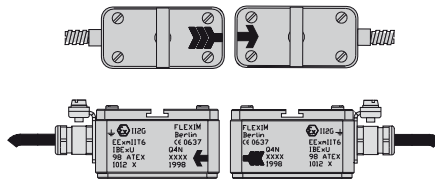

Fig. 6.1: Correct positioning of the transducers

Select the installation instructions that correspond to the supplied transducer mounting fixture.

6.1 Mounting the Transducers with Fastening Shoes and Chains

- Insert the transducers in the fastening shoes. Turn the screw on the upper side of the fastening shoes by 90 ° to engage and lock its end in the groove on the top of the inserted transducer.
- Insert the ruler in the lateral slot of the fastening shoes. Adjust the displayed transducer distance (see section 9.6). Fix the transducers with the plastic screws on the transducer cable side of the fastening shoes.
- Place the fastening shoes/ruler assembly on the pipe at the measuring point. Insert the last ball in the slot on the upper side of one of the fastening shoe.

- Place the chain around the pipe.
- Tighten the chain and insert it in the second slot on the top of the fastening shoe. Mount the second transducer in the same way.

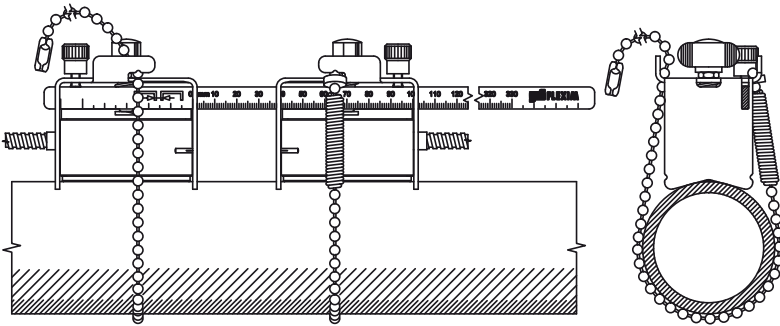

Fig. 6.2: Mounting the Transducers with Fastening Shoes and Chains

Extension of the Ball Chain

To extend the chain, insert the last ball of the extension in the fastening clip of the ball chain. The spare fastening clips supplied with the chain can be used to repair a broken chain.

6.1.1 Mounting the Transducers with Magnetic Fastening Shoes

- Insert the transducers in the fastening shoes. Turn the screw on the upper side of the fastening shoes by 90° in order to engage and lock its extremity in the groove on the top of the inserted transducer. Apply some coupling compound to the contact surface of the transducers.
- Insert the ruler in the lateral slot of the fastening shoes.
- Adjust the displayed transducer distance (see section 9.6). Fix the transducers with the plastic screws on the transducer cable side of the fastening shoes.
- Place the fastening shoe/ruler assembly on the pipe at the measuring point. There must be no air pockets between pipe wall and contact surface of the transducer. Adjust the transducer distance again.

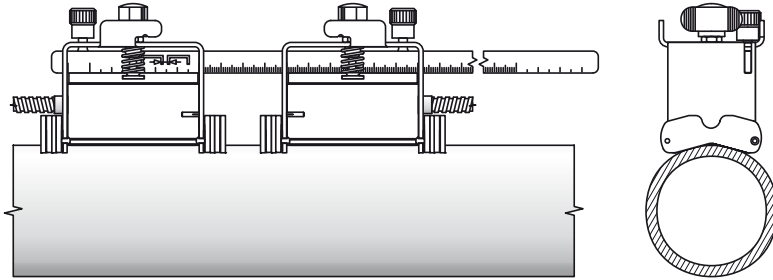

Fig. 6.3: Mounting the transducers with magnetic fastening shoes

6.1.2 Mounting the Transducers with Portable Variofix Rail PVX with Chains

Normally, each transducer is mounted to its own Variofix rail. If the transducer distance is small and both transducers are on the same side of the pipe (reflection mode), they can be fixed in one Variofix rail.

Preparing and Fixing the Variofix Rail

- Adjustment of the Variofix rail to transducer width:
 - Loosen the 4 screws (1) for the adjustment of the rails (2) with a M8 wrench (see Fig. 6.4).
 - Place one transducer (3) in the center between the rails.
 - Press the two rails (2) together and tighten the 4 screws (1). The transducer can be shifted and removed.
 - Remove the transducer.
- Loosen the chain tensioners (4), but do not unscrew them completely.
- If the chain has not yet been mounted to the rail support (6):
Compress the spring of the chain tensioner (4) with the cylinder (7) while pushing the chain tensioner (4) in the horizontal groove (5) of the rail support (6).
- Place the Variofix rail on the pipe. Both rail supports (6) must be completely supported by the pipe. Lay the ball chain (8) around the pipe (if the pipe is vertical, start with the upper ball chain).
- Press the chain tensioner (4) completely in and push the ball chain (8) in the other groove (9) of the rail support.
- Fix the second ball chain (8) in the same way.
- Tension the ball chains (8) by tightening the chain tensioners (4).
- Repeat the steps if the second transducer is fixed to its own Variofix rail.

Fixing the Transducer

- Force apart the legs of the spring clip (10) and clamp it over the outer side of the rails (2). The height where the spring clip will snap in depends on the height of the transducer.
- Apply some coupling compound to the contact surface of the transducer.
- Place the transducer between the rails (2). Observe the mounting direction (see Fig. 9.1 and Fig. 6.4).
- Push the spring clip (10) over the transducer until the knurled screw (11) is positioned over the blind hole of the transducer.
- Fix the transducer by tightening the knurled screw by hand (11).
- Repeat the steps for fixing the second transducer.
- Adjust the transducer distance by loosening the knurled screw (11) of a spring clip (10) and shifting the transducer.

1	screw	7	cylinder
2	rail	8	ball chain
3	transducer	9	groove
4	chain tensioner	10	spring clip
5	horizontal groove	11	knurled screw
6	rail support		

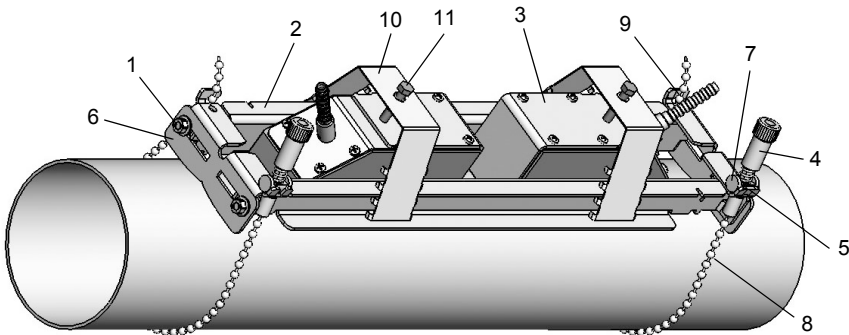

Fig. 6.4: Variofix rail with chains

7 Installation of the Temperature Probes (Optional)

7.1 Mounting the Temperature Probes

- Remove rust, insulation material and loose paint to get a good thermal contact.
- Clean the pipe.

Temperature Probe Pt100 (Response Time 8 s)

- Fix the protection plate and the isolation foam to the temperature probe (see Fig. 7.1 and Fig. 7.2).
- Apply a film of thermal conductivity paste (not supplied by FLEXIM) on the contact surface of the temperature probe.
- Take the spring end of the ball chain and insert the last ball in one of the slots on the top of the temperature probe.

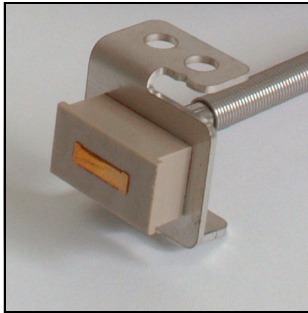

Fig. 7.1: Temperature probe

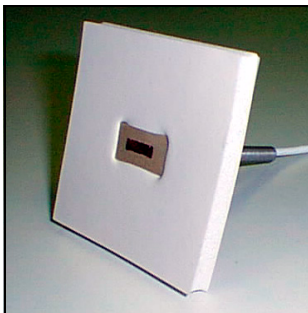

Fig. 7.2: Temperature probe with protection plate and isolation foam

- Place the chain around the pipe. Tighten the chain and insert it in the other slot of the temperature probe (see Fig. 7.3).

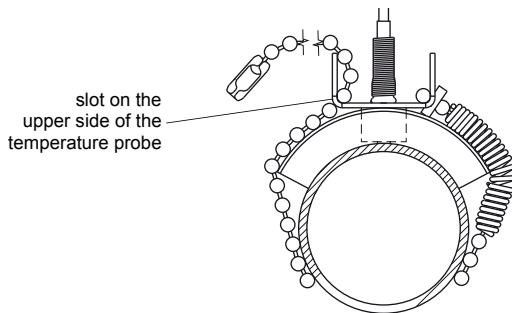

Fig. 7.3: Mounted temperature probe

8 Start-up

8.1 Switching on/off

```
FLEXIM FLUXUS
F601-XXXXXXX
```

Press key C to switch on the transmitter.

After the transmitter has been switched on, the display indicates which transducer has been detected at which channel.

Afterwards, the serial number of the transmitter is displayed for a short time.

Data can not be entered while the serial number is displayed.

```
>PAR<mea opt sf
Parameter
```

After the initialization, the main menu is displayed in the selected language. The language of the display can be set (see section 8.5).

Press key BRK three times to switch off the transmitter.

8.2 Connection of the Transducers

- Pull up the socket cover.
- Insert the connector of the transducer cable in the socket of the transmitter. The red point on the connector (a) must face the red marking (b) on the socket (see Fig. 8.1).

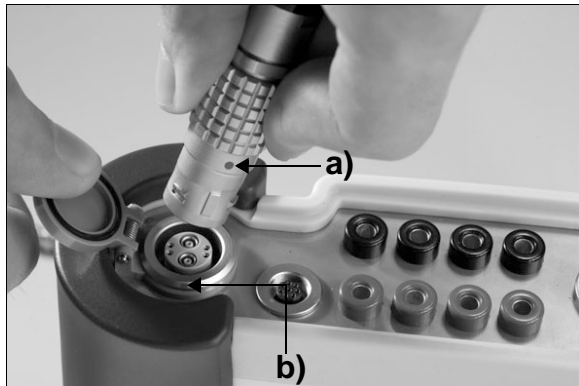

Fig. 8.1: Connection of the transducers to the transmitter

8.3 Displays



8.3.1 Main menu

```
>PAR<mea opt sf
Parameter
```

The main menu contains the following program branches:

- par (Parameter)
- mea (Measuring)
- opt (Output Options)
- sf (Special Function)

The selected program branch is displayed in capital letters between arrows. The complete designation of the selected program branch is displayed in the lower line.

Select a program branch by pressing key  and . Press ENTER.

Note!

By pressing key BRK, the measurement will be stopped and the main menu selected.

Note!

In this user manual, all program entries and keys are indicated with typewriter characters (`Parameter`). The menu items are separated from the main menu by a backslash "\".

8.3.2 Overview of the Program Branches

- **Program branch Parameter**
input of the pipe and medium parameters
- **Program branch Measuring**
processing of the steps for the measurement
- **Program branch Output Options**
setting of the physical quantity, the unit of measurement and the parameters for the measured value output
- **Program branch Special Funct.**
contains all functions that are not directly related to the measurement

For an overview of the program branches see figure below. For a detailed overview of the menu structure see annex A.

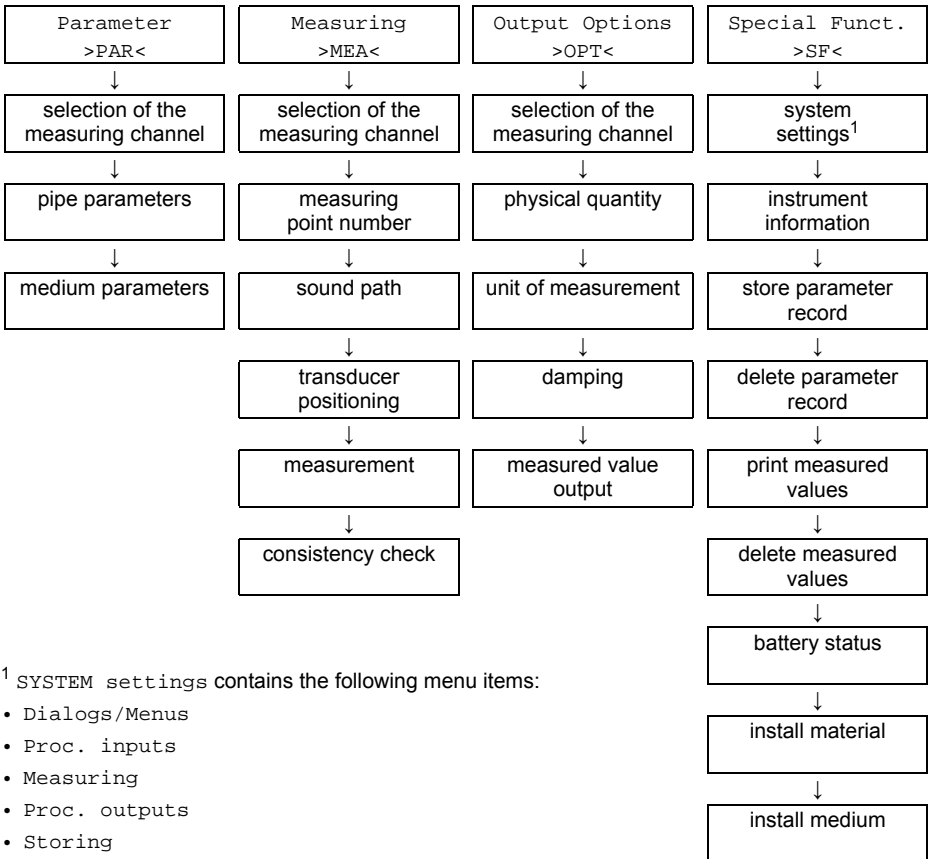

¹ SYSTEM settings contains the following menu items:

- Dialogs/Menu
- Proc. inputs
- Measuring
- Proc. outputs
- Storing
- serial transmis.
- Miscellaneous
- Set Clock
- Libraries

8.3.3 Navigation

A vertical arrow \updownarrow will be displayed if the menu item contains a scroll list. The current list item will be displayed in the lower line.

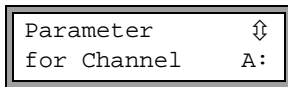

Use key \uparrow **8** and \downarrow **2** to select a list item in the lower line. Press ENTER.

Some menu items contain a horizontal scroll list in the lower line. The selected list item is displayed in capital letters between arrows.



Press key \leftarrow **4** and \rightarrow **6** to scroll through the lower line and select a list item. Press ENTER.

Some menu items contain a horizontal scroll list in the upper line. The selected list item is displayed in capital letters between arrows. The current value of the list item is displayed in the lower line.

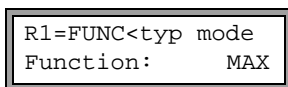

Press key \leftarrow **4** and \rightarrow **6** to scroll through the upper line and select a list item.

Press key \uparrow **8** and \downarrow **2** to scroll through the lower line and select a value for the selected list item.

Press ENTER.

8.4 HotCodes

A HotCode is a key sequence used to activate certain settings:

- language selection (see section 8.5)
- activating the SuperUser mode (see section 16)
- activating the FastFood mode (see section 11.6)
- manual input of the lower limit for the inner pipe diameter (see section 11.8)

A HotCode can only be entered in the main menu immediately after the transmitter has been switched on. The HotCode will not be displayed during the input.

8.5 Language Selection

The transmitter can be operated in the languages listed below. The language can be selected with the following HotCodes:

Table 8.1: Language HotCodes

909031	Dutch
909033	French
909034	Spanish
909044	English
909049	German

Depending on the technical data of the transmitter, some of the languages might not be implemented.

When the last digit has been entered, the main menu will be displayed in the selected language.

The selected language remains activated when the transmitter is switched off and on again. After a cold start, the default language set by the manufacturer is activated.

9 Basic Measurement

The pipe and medium parameters are entered for the selected measuring point (see chapter 4). The parameter ranges are limited by the technical characteristics of the transducers and of the transmitter.

Note! During the parameter input, the transducers must be connected to the transmitter.

Note! The parameters will only be stored when the program branch `Parameter` has been edited in its entirety.

9.1 Input of the Pipe Parameters

```
>PAR<mea opt sf
Parameter
```

Select the program branch `Parameter`. Press ENTER.

```
Parameter      ⇕
for Channel    A:
```

Select the channel for which the parameters are to be entered. Press ENTER.

This display will not be indicated if the transmitter has only one measuring channel.

If `Parameter from:` is displayed, at least one parameter record is stored in the transmitter and can be selected. A parameter set contains all data necessary for a measurement:

- pipe parameters
- medium parameters
- transducer parameters
- output options

A parameter record can be defined for each measuring task (see chapter 13).

9.1.1 Outer Pipe Diameter/Pipe Circumference

```
Outer Diameter
  100.0      mm
```

Enter the outer pipe diameter. Press ENTER.

```
Outer Diameter
1100.0     MAXIMAL
```

An error message will be displayed if the entered parameter is outside of the range. The limit will be displayed.

example: upper limit 1100 mm for the connected transducers and for a pipe wall thickness of 50 mm.

It is possible to enter the pipe circumference instead of the outer pipe diameter (see section 15.2.1).

If the input of the pipe circumference has been activated and 0 (zero) is entered for the Outer Diameter, the menu item Pipe Circumfer. will be displayed. If the pipe circumference is not to be entered, press key BRK to return to the main menu and start the parameter input again.

9.1.2 Pipe Wall Thickness

Wall Thickness	
3.0	mm

Enter the pipe wall thickness. Press ENTER.

Note! The inner pipe diameter (= outer pipe diameter - 2x pipe wall thickness) is calculated internally. If the value is not within the inner pipe diameter range of the connected transducers, an error message will be displayed.

It is possible to change the lower limit of the inner pipe diameter for a given transducer type (see section 11.8).

9.1.3 Pipe Material

The pipe material must be selected to be able to determine the sound velocity. The sound velocity for the materials in the scroll list are stored in the transmitter.

Pipe Material	⇕
Carbon Steel	

Select the pipe material.

If the medium is not in the scroll list, select Other Material. Press ENTER.

It can be specified which materials will be displayed in the scroll list (see section 14.5).

When the pipe material has been selected, the corresponding sound velocity is set automatically. If Other Material has been selected, the sound velocity must be entered.

c-Material	
3230.0	m/s

Enter the sound velocity of the pipe material. Press ENTER.

Note! Enter the sound velocity of the material (i.e. longitudinal or transversal velocity) which is nearer to 2500 m/s.

For the sound velocity of some materials see annex C, Table C.1.

9.1.4 Pipe Lining

Lining	
no	>YES<

If the pipe has an inner lining, select `yes`. Press `ENTER`.

If `no` is selected, the next parameter will be displayed (see section 9.1.5).

Lining	↑↓
Bitumen	

Select the lining material.

If the material is not in the scroll list, select `Other Material`. Press `ENTER`.

It can be specified which materials will be displayed in the scroll list (see chapter 9.1.5).

If `Other Material` is selected, the sound velocity must be entered.

c-Material	
3200.0	m/s

Enter the sound velocity of the lining material. Press `ENTER`.

For the sound velocity of some materials see annex C, Table C.1.

Liner Thickness	
3.0	mm

Enter the thickness of the liner. Press `ENTER`.

Note!

The inner pipe diameter (= outer pipe diameter - 2x pipe wall thickness - 2x liner thickness) is calculated internally. If the value is not within the inner pipe diameter range of the connected transducers, an error message will be displayed.

It is possible to change the lower limit of the inner pipe diameter for a given transducer type (see section 11.8).

9.1.5 Pipe Roughness

The flow profile of the medium is influenced by the roughness of the inner pipe wall. The roughness will be used for the calculation of the profile correction factor. As, in most cases, the pipe roughness can not be exactly determined, it has to be estimated.

For the roughness of some materials see annex C, Table C.2.

Roughness	
0.4	mm

Enter the roughness of the selected pipe or liner material.

Change the value according to the condition of the inner pipe wall. Press `ENTER`.

9.2 Input of the Medium Parameters

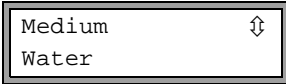

Select the medium from the scroll list.

If the medium is not in the scroll list, select `Other Medium`. Press ENTER.

It is possible to specify which media will be displayed in the scroll list (see chapter 14.5).

For the programmed parameters of common media see annex C, Table C.3.

If a medium is selected from the scroll list, the menu item for the input of the medium temperature is displayed directly (see section 9.2.4).

If `Other Material` is selected, the medium parameters must be entered first.

- min. and max. sound velocity
- kinematic viscosity
- density

9.2.1 Sound Velocity

The sound velocity of the medium is used for the calculation of the transducer distance at the beginning of the measurement. However, the sound velocity does affect the measuring result directly. Often, the exact value of the sound velocity for a medium is unknown. Therefore, a range of possible values for the sound velocity must be entered.

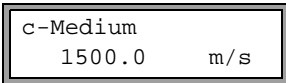

Enter the average sound velocity of the medium. Press ENTER.

This display will only be indicated if `Other Medium` has been selected.

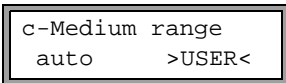

Select `auto` or `user`. Press ENTER.

`auto`: The area around the average sound velocity is defined by the transmitter.

`user`: The area around the average sound velocity must be entered.

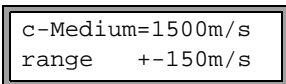

Enter the area around the average sound velocity of the medium. Press ENTER.

This display will only be indicated if `user` has been selected.

9.2.2 Kinematic Viscosity

The kinematic viscosity affects the flow profile of the medium. The entered value and other parameters are used for the profile correction.

Kinem.Viscosity
1.00 mm ² /s

Enter the kinematic viscosity of the medium. Press ENTER.

This display will only be indicated if Other Medium has been selected

9.2.3 Density

The density is used to calculate the mass flow rate (product of the volumetric flow rate and the density).

Note!	If the mass flow rate is not measured, press ENTER. The other measuring results will not be affected.
--------------	---

Density
1.00 g/cm ³

Enter the operating density of the medium. Press ENTER.

This display will only be indicated if Other Medium has been selected.

9.2.4 Medium Temperature

The medium temperature is used for the interpolation of the sound velocity and for the calculation of the recommended transducer distance at the beginning of the measurement.

During the measurement, the medium temperature is used for the interpolation of the density and the viscosity of the medium.

The value entered here will be used for the calculations if the medium temperature is not measured and fed to an input of the transmitter.

Medium Temperat.
20.0 C

Enter the medium temperature. The value must be within the operating temperature range of the transducers. Press ENTER.

9.2.5 Medium Pressure

The medium pressure is used for the interpolation of the sound velocity .

Fluid pressure
1.00 bar

Enter the medium pressure. Press ENTER.

This display will only be indicated if Special Funct.\SYSTEM settings\Dialogs/Menu/Fluid pressure is activated.

9.3 Other Parameters

9.3.1 Transducer Parameters

If transducers are detected on a measuring channel, the parameter input finished. Press ENTER. The main menu will be displayed.

If no or special transducers are connected, the transducer parameters have to be entered.

```
Transducer Type ↕
Standard
```

Select `Standard` to use the standard transducer parameters stored in the transmitter.

Select `Special Version` to enter the transducer parameters. The transducer parameters must be provided by the transducer manufacturer.

Press ENTER.

Note! If standard transducer parameters are used, FLEXIM can not guarantee for the precision of the measured values. A measurement might even be impossible.

```
Transd. Data 1
35.99
```

If `Special Version` has been selected, enter the 6 transducer parameters specified by the manufacturer. Press ENTER after each input.

9.4 Selection of the Channels

The channels on which will be measured can be activated individually.

```
par>MEA<opt sf
Measuring
```

Select program branch `Measuring`. Press ENTER.

```
par>MEA<opt sf
NO DATA!
```

If this error message is displayed, the parameters are not complete. Enter the missing parameters in the program branch `Parameter`.

```
CHANN: >A< B Y Z
MEASUR  ✓  ✓  -  .
```

The channels for the measurement can be activated and deactivated.

- ✓: the channel is active
- : the channel is not active
- : the channel can not be activated

This display will not be indicated if the transmitter has only one measuring channel.

Note! A channel can not be activated if the parameters are not valid, e.g. if the parameters in the program branch `Parameter` of the channel are not complete.

- Select a channel with key \leftarrow **4** and **6** \rightarrow .
- Press key \leftarrow **8** \rightarrow to activate or deactivate the selected channel. Press ENTER.

A deactivated channel will be ignored during the measurement. Its parameters will remain unchanged.

If the data logger or the serial interface is activated, the measuring point number must be entered:

A:Meas.Point No. :
xxxx (\uparrow \downarrow \leftarrow \rightarrow)

Enter the measuring point number. Press ENTER.

If arrows are displayed in the lower line on the right, ASCII text can be entered. If no arrows are displayed, only digits, point and hyphen can be entered.

9.5 Defining the Number of Sound Paths

The number of transits of the ultrasonic waves through the medium depends on the placement of the transducers on the pipe.

If the number of transits is odd (diagonal mode), the transducers will be mounted on opposite sides of the pipe.

If the number of transits is even (reflection mode), the transducers will be mounted on the same side of the pipe.

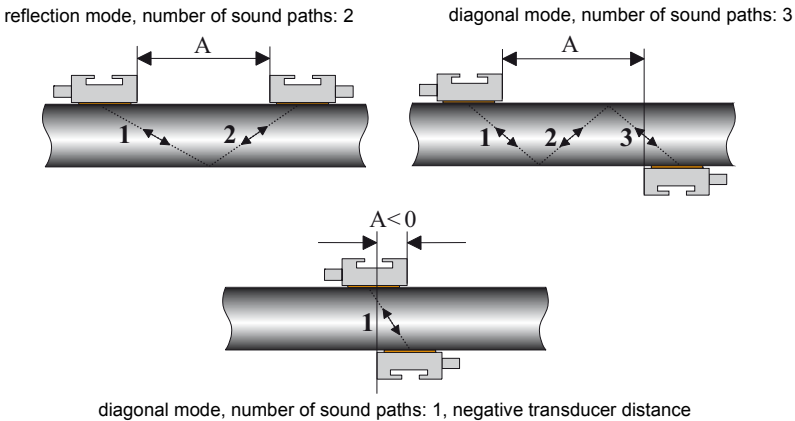

Fig. 9.1: Sound path and transducer distance (A)

A higher number of transits means increased accuracy of the measurement. However, the increased transit distance results in a higher attenuation of the signal.

The reflections on the opposite pipe wall and deposits on the inner pipe wall cause additional amplitude losses of the sound signal.

If the signal is attenuated strongly, e.g. by the medium, the pipe, deposits, etc., the number of sound paths must be set to 1 if necessary.

Note! Exact positioning of the transducers is easier for an even number of transit paths (reflection mode) than for an odd number (diagonal mode).

A: Sound Path
2 NUM

A value for the number of sound paths corresponding to the connected transducers and the entered parameters will be recommended. Change the value if necessary. Press ENTER.

9.6 Transducer Distance

Transd. Distance
A:54 mm Reflec

A value for the transducer distance is recommended. Fix the transducers (see chapter 6). Adjust the transducer distance.

Press ENTER.

- A - measuring channel
- Reflec - reflection mode
- Diagon - diagonal mode

The transducer distance displayed here is the distance between the inner edges of the transducers.

In case of a measurement in diagonal mode on very small pipes, a negative transducer distance is possible (see Fig. 9.1).

Note! The accuracy of the recommended transducer distance depends on the accuracy of the entered pipe and medium parameters.

9.6.1 Fine Adjustment of the Transducer Distance

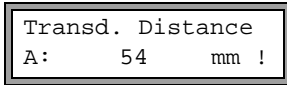

If the displayed transducer distance is adjusted, press ENTER.

The measuring for the positioning of the transducers is started.



The amplitude of the received signal is displayed by the bar graph S=.

If the LED of the measuring channel lights green, the signal is sufficient for a measurement.

If the LED of the measuring channel lights red, the signal is not sufficient for a measurement.

- Shift a transducer slightly in the range of the recommended transducer distance until the LED of the measuring channel lights green.

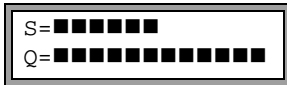

The following can be displayed in the upper line with key **9** and in the lower line with key **3**:

- transducer distance
- bar graph Q= (signal quality), must have max. length
- transit time time in μ s
- bar graph S= (signal amplitude)

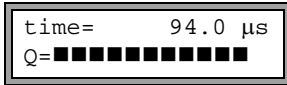

If the signal is not sufficient for measurement, Q= UNDEF will be displayed.

In case of large deviations, check if the entered parameters are correct or repeat the measurement at a different point on the pipe.

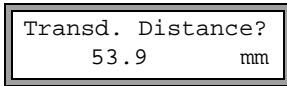

After the precise positioning of the transducers, the recommended transducer distance is displayed again.

Enter the actual (precise) transducer distance. Press ENTER.

Repeat the steps for all channels on which will be measured. The measurement will be started automatically afterwards.

9.6.2 Consistency Check

If a wide range for the sound velocity has been entered in the program branch Parameter or the exact parameters of the medium are not known, a consistency check is recommended.

The transducer distance can be displayed during measurement by scrolling with key **9**.

L=(50.0) 54.0 mm
54.5 m3/h

The optimum transducer distance (here: 50.0 mm) is displayed in the upper line in parentheses, followed by the entered transducer distance (here: 54.0 mm). The latter value must correspond to the adjusted transducer distance. Press ENTER to optimize the transducer distance.

The optimum transducer distance is calculated on the basis of the measured sound velocity. It is therefore a better approximation than the first recommended value which had been calculated on the basis of the sound velocity range entered in the program branch Parameter.

If the difference between the optimum and the entered transducer distance is less than specified in Table 9.1, the measurement is consistent and the measured values are valid. The measurement can be continued.

If the difference is greater, adjust the transducer distance to the displayed optimum value. Afterwards, check the signal quality and the signal amplitude bar graph (see section 9.6.1). Press ENTER.

Table 9.1: Standard values for signal optimization

transducer frequency (third character of the technical type)	Difference between the optimum and the entered transducer distance [mm]	
	shear wave transducer	lamb wave transducer
G	20	-50...+100
H	-	-35...+60
K	15	-25...+40
M	10	-10...+20
P	8	-6...+10
Q	6	-3...+5
S	3	-

Transd. Distance?
50.0 mm

Enter the new adjusted transducer distance. Press ENTER.

L=(51.1) 50.0 mm
54.5 m3/h

Scroll with key  again until the transducer distance is displayed and check the difference between the optimum and the entered transducer distance. Repeat the steps if necessary.

Note! Never change the transducer distance during the measurement without restarting the consistency check.

Repeat the steps for all channels on which a measurement is being made.

9.6.3 Value of the Sound Velocity

The sound velocity of the medium can be displayed during the measurement by pressing key .

If an approximate range for the sound velocity has been entered in the program branch `Parameter` and the transducer distance has been optimized afterwards as described in section 9.6.2, it is recommended to write down the sound velocity for the next measurement. By doing this, it will not be necessary to repeat the fine adjustment.

Also write down the medium temperature because the sound velocity depends on the temperature. The value can be entered in the program branch `Parameter` or a user defined medium can be created for this sound velocity (see section 14.2 and 14.3).

9.7 Start of the Measurement

A:Volume Flow
31.82 m ³ /h

The measured values are displayed in the lower line. Press ENTER to return to the fine adjustment of the transducer distance (see section 9.6.1).

If more than one measuring channel is available/activated, the transmitter works with an integrated measuring point multiplexer providing simultaneous measurement on the different measuring channels.

The flow is measured on one measuring channel for approx. 1 s, then the multiplexer switches to the next activated channel.

The time necessary for the measurement depends on the measuring conditions. E.g. if the measuring signal can not be detected immediately, the measurement might be > 1 s.

The outputs and the serial interface continuously receive the measured values of the corresponding channel. The results are displayed according to the actually selected output options. The default unit of measurement of the volumetric flow rate is m³/h. For the selection of the values to be displayed and for the setting of the output options see chapter 10. For further measuring functions see chapter 11.

9.8 Detection of the Flow Direction

The flow direction in the pipe can be detected with the help of the displayed volumetric flow rate in conjunction with the arrow on the transducers:

- The medium flows in the direction of the arrow if the displayed volumetric flow rate is positive (e.g. 54.5 m³/h).
- The medium flows against the direction of the arrow if the displayed volumetric flow rate is negative (e.g. -54.5 m³/h).

9.9 Stopping the Measurement

The measurement will be interrupted by pressing key BRK.

Note!

Be careful not to stop a current measurement by inadvertently pressing key BRK!

10 Displaying the Measured Values

The physical quantity is set in the program branch `Output Options` (see section 10.1). During the measurement, the designation of the physical quantity is displayed in the upper line, the measured value in the lower line. The display can be adapted (see section 10.3).

10.1 Selection of the Physical Quantity and of the Unit of Measurement

The following physical quantities can be measured:

- **sound velocity**
- **flow velocity**: is calculated on the basis of the measured transit time difference
- **volumetric flow rate**: is calculated by multiplying the flow velocity by the cross-section of the pipe
- **mass flow rate**: is calculated by multiplying the volumetric flow rate by the operating density of the medium
- **heat flow (optional)**: is calculated on the basis of the volumetric flow rate, the measured temperatures of the supply and return lines, and the heat flow coefficients of the medium

The physical quantity is selected as follows:

```
par mea >OPT< sf
Output Options
```

Select the program branch `Output Options`. Press **ENTER**.

```
Output Options ⇅
for Channel A:
```

Select the channel for which the physical quantity is to be entered. Press **ENTER**.

This display will not be indicated, if the transmitter has only one measuring channel.

```
Physic. Quant. ⇅
Volume Flow
```

Select the physical quantity in the scroll list. Press **ENTER**.

```
Volume in: ⇅
m3/h
```

For the selected physical quantity (except for the sound velocity), a scroll list with the available units of measurement is displayed. The previously selected unit of measurement is displayed first.

Select the unit of measurement of the selected physical quantity. Press **ENTER**.

Press **BRK** to return to the main menu. The further menu items of the program branch `Output Options` are for the activation of the measured value output.

Note!

If the physical quantity or the unit of measurement is changed, the settings of the outputs will have to be checked (see chapter 21).

10.2 Toggling between the channels

If more than one channel is available/activated, the display for the measured values can be adapted as follows:

- AutoMux mode
 - all channels
 - only calculation channels
- HumanMux mode

Key  toggles between the modes.

10.2.1 AutoMux Mode

In the AutoMux mode, the display and the measuring process are synchronized. The channel on which a measurement is being made is displayed in the upper line on the left.

The measured values are displayed as configured in the program branch `Output Options` (see section 10.1). When the multiplexer switches to the next channel, the display is updated.

A:Volume Flow	
54.5	m ³ /h

B:Flow Velocity	
1.25	m/s

The AutoMux mode is the default display mode. It is activated automatically after a cold start.

All Channels

The measured values of all channels (measuring and calculation channels) are displayed. The next active channel is displayed after min. 1.5 s.

Only Calculation Channels

Only the measured values of the calculation channels are displayed. The next active calculation channel is displayed after min. 1.5 s.

This mode can only be activated if at least 2 calculation channels are active.

10.2.2 HumanMux Mode

In the HumanMux mode, the measured values of one channel are displayed. The measurement on the other channels is continued, but not displayed.

B:Flow Velocity	
1.25	m/s

The selected channel is displayed left in the upper line.

Press key  to display the next activated channel. The measured values of the selected channel will be displayed as configured in the program branch `Output Options` (see section 10.1).

10.3 Adjustment of the Display



During the measurement, the display can be adapted as to display two measured values simultaneously (one in each line of the display). This does not affect totalizing, storing of measured values, measured value output, etc.

The following information can be displayed in the upper line:

- designation of the physical quantity
- totalizer values, if activated
- temperatures assigned to the channel and their difference if the temperature is measured
- date and time at which the data logger will be full
- measuring mode
- transducer distance
- time remaining until the automatic stop of a time-programmable measurement
- alarm state indication if it is activated (see section 21.7.5) and if alarm outputs are activated (see section 21.6).
- charge state of the battery

The following information can be displayed in the lower line:

- flow velocity
- sound velocity
- mass flow rate
- volumetric flow rate
- heat flow

Press key  during the measurement to change the display in the upper line, press key  to change the display in the lower line.

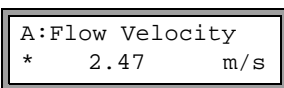

A:Flow Velocity
* 2.47 m/s

The character * indicates that the displayed value (here: flow velocity) is not the selected physical quantity.

10.4 Status Line

Important data on the ongoing measurement are displayed in the status line. The quality and precision of the ongoing measurement can be estimated.

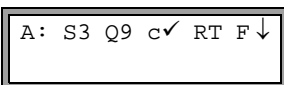

A: S3 Q9 c✓ RT F ↓

Press key  during the measurement to scroll through the upper line to the status line.

	value	explanation
S		signal amplitude
	0	< 5 %
	9	≥ 90 %
Q		signal quality
	0	< 5 %
	9	≥ 90 %
c		sound velocity comparison of the measured and the expected sound velocity of the medium. The expected sound velocity is calculated on the basis of the medium parameters (medium selected in the program branch <code>Parameter</code> , temperature dependency, pressure dependency).
	√	ok, is equal to the expected value
	↑	> 20 % of the expected value
	↓	< 20 % of the expected value
	?	unknown, can not be measured
R		flow profile information about the flow profile based on the Reynolds number
	T	fully turbulent flow profile
	L	fully laminar flow profile
	↕	the flow is in the transition range between laminar and turbulent flow
	?	unknown, can not be calculated
F		flow velocity comparison of the measured flow velocity with the flow limits of the system
	√	ok, the flow velocity is not in the critical range
	↑	the flow velocity is higher than the current limit
	↓	the flow velocity is lower than the current cut-off flow (even if it is not set to zero)
	0	the flow velocity is in the offset range of the measuring method
?	unknown, can not be measured	

10.5 Transducer distance

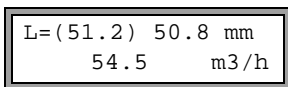

By pressing key **9** during the measurement, it is possible to scroll to the display of the transducer distance.

The optimum transducer distance (here: 51.2 mm) is displayed in parentheses in the upper line, followed by the entered transducer distance (here: 50.8 mm).

The optimum transducer distance might change during the measurement (e.g. due to temperature fluctuations).

A deviation from the optimum transducer distance (here: -0.4 mm) is compensated internally.

Note! Never change the transducer distance during the measurement!

11 Advanced Measuring Functions

11.1 Damping Factor

Each displayed measured value is a floating average of all measured values of the last x seconds, with x being the damping factor. A damping factor of 1 s means that the measured values are not averaged because the measuring rate is approx 1/s. The default value of 10 s is appropriate for normal flow conditions.

Strongly fluctuating values caused by high flow dynamics require a higher damping factor.

Select the program branch `Output Options`. Press ENTER until the menu item `Damping` is displayed.

Damping
10 s

Enter the damping factor. Press ENTER.

Press BRK to return to the main menu.

11.2 Totalizers

Heat quantity, total volume or total mass of the medium at the measuring point can be determined.

There are two totalizers, one for the positive flow direction, one for the negative flow direction.

The unit of measurement used for totalizing corresponds to the heat, volume or mass unit selected for the physical quantity.

The value of a totalizer consists of max. 11 digits, including max. 4 decimal places. For the adjustment of the number of decimal places see section 16.6.





A:Volume Flow
54.5 m3/h

To activate the totalizers, press key  during the measurement (see Table 11.1).

A: 32.5 m3
54.5 m3/h

The value of the totalizer will be displayed in the upper line (here: the volume which has passed through the pipe at the measuring point in the positive flow direction after the activation of the totalizers).

Table 11.1: Keys for display of the totalizers

activation	press key  once during the measurement
deactivation	press key  three times during the measurement
display of the totalizer for the positive flow direction	press key  during the measurement
display of the totalizer for the negative flow direction	press key  during the measurement
reset of the Totalizers to zero	press key  three times during measurement

```
A:NO COUNTING  !
      3.5      m/s
```

This error message will be displayed if the totalizers of a measuring channel used for measuring the flow velocity are to be activated. The flow velocity can not be totalized.

Note! The totalizers can only be activated for the measuring channel whose measured values are displayed at the moment.

Note! The pressing of a key will only influence the totalizers if the totalizer is displayed in the upper line.

11.2.1 Storing the Values of the Totalizers

During the Heat Flow Measurement

During the heat flow measurement, it is possible to output and store the values of the heat quantity totalizer and of the volume totalizer. Select `Special Funct.\SYSTEM settings\Measuring\heat+flow quant..`

```
heat+flow quant.
off                >ON<
```

Select `on` to store and output the values of the heat quantity totalizer and the volume totalizer during the heat flow measurement.

Press ENTER.

When the Measurement Is Stopped

The behavior of the totalizers when the measurement is stopped or after a RESET of the transmitter is set in `Special Funct.\SYSTEM settings\Measuring\Quantity recall.`

```
Quantity recall
off                >ON<
```

If `on` is selected, the values of the totalizers will be stored and used for the next measurement.

If `off` is selected, the totalizers will be reset to zero.

Selection of the Totalizers for Storing

It is possible to store only the value of the totalizer that is currently displayed or one value for each flow direction. Select `Special Funct.\SYSTEM settings\Storing\Quantity Storage`.

```
Quantity Storage
one                >BOTH<
```

If `one` is selected, only the value of the totalizer that is currently displayed will be stored.

If `both` is selected, the values of the totalizers totalizer for both flow directions will be stored.

Press ENTER.

11.2.2 Overflow of the Totalizers

The overflow behavior of the totalizers can be set:

Without overflow:

- The value of the totalizer increases to the internal limit of 10^{38} .
- if necessary, the values will be displayed as exponential numbers ($\pm 1.00000E10$). The totalizer can only be reset to zero manually.

With overflow:

- The totalizer will be reset to zero automatically when ± 9999999999 is reached.

Select `Special Funct.\SYSTEM settings\Measuring\Quant. wrapping`.

```
Quant. wrapping
off                >ON<
```

Select `on` to work with overflow. Select `off` to work without overflow. Press ENTER.

Independently of the setting, the totalizers can be reset to zero manually.

Note!

The overflow of a totalizer influences all output channels, e.g. data logger, online output.

The output of the sum of both totalizers (the throughput ΣQ) via an output will not be valid after the first overflow (wrapping) of one of the corresponding totalizers.

To signalize the overflow of a totalizer, an alarm output with the switching condition `QUANT.` and the type `HOLD` must be activated.

11.3 Upper Limit of the Flow Velocity

Single outliers caused by heavily disturbed surroundings can appear among the measured values of the flow velocity. If the outliers are not ignored, they will affect all derived physical quantities, which will then be unsuitable for the integration (e.g. pulse outputs).

It is possible to ignore all measured flow velocities higher than an upper limit. These measured values will be marked as outliers.

The upper limit of the flow velocity is set in `Special Funct.\SYSTEM settings\Measuring\Velocity limit`.

Velocity limit
0.0 m/s

Enter 0 (zero) to switch off the checking for outliers.

Enter a limit > 0 to switch on the checking for outliers. The measured flow velocity will then be compared to the entered upper limit.

Press ENTER.

If the flow velocity is higher than the upper limit,

- the flow velocity will be marked as invalid. The physical quantity can not be determined.
- the LED of the measuring channel will light red
- "!" will be displayed after the unit of measurement (in case of a normal error, "?" is displayed)

Note!

If the upper limit is too low, a measurement might be impossible because most of the measured values will be marked as "invalid".

11.4 Cut-off Flow

The cut-off flow is a lower limit for the flow velocity. All measured flow velocities that are lower than the limit and their derived values are set to zero.

The cut-off flow can depend on the flow direction or not. The cut-off flow is set in `Special Funct.\SYSTEM settings\Measuring\Cut-off Flow`.

Cut-off Flow
absolut >SIGN<

Select `sign` to define a cut-off flow in dependence on the flow direction. Two independent limits are set for the positive and negative flow directions.

Select `absolut` to define a cut-off flow independently of the flow direction. A limit is set for the absolute value of the flow velocity.

Press ENTER.

```
Cut-off Flow
factory >USER<
```

Select `factory` to use the default limit of 2.5 cm/s (0.025 m/s) for the cut-off flow.

Select `user` to enter the cut-off flow.

Press ENTER.

If `Cut-off Flow\sign` and `user` are selected, two values will have to be entered:

```
+Cut-off Flow
  2.5 cm/s
```

Enter the cut-off flow. Press ENTER.

All positive values of the flow velocity that are lower than this limit will be set to zero.

```
-Cut-off Flow
 -2.5 cm/s
```

Enter the cut-off flow. Press ENTER.

All negative values of the flow velocity greater than this limit will be set to zero.

If `Cut-off Flow\absolut` and `user` is selected, only one value will have to be entered:

```
Cut-off Flow
  2.5 cm/s
```

Enter the cut-off flow. Press ENTER.

The absolute values of all flow velocity values that are lower than this limit will be set to zero.

11.5 Uncorrected Flow Velocity

For special applications, the uncorrected flow velocity might be of interest.

The profile correction for the flow velocity is activated in `Special Funct.\SYSTEM settings\Measuring\Flow Velocity`.

```
Flow Velocity
>NORMAL< uncorr.
```

Select `normal` to display and output the flow velocity with profile correction.

Select `uncorr.` to display the flow velocity without profile correction. Press ENTER.

```
A:PROFILE CORR.
>NO< yes
```

If `uncorr.` is selected, it has to be confirmed each time the program branch `Measuring` is selected if the profile correction is to be used.

```
A:FLOW VELOCITY
  2.60 m/s
```

If `no` is selected, the profile correction will be switched off.

All physical quantities will be calculated with the uncorrected flow velocity.

During the measurement, the designation of the physical quantity will be displayed in capital letters to indicate that the value is uncorrected.

Press ENTER.

```
A:PROFILE CORR.
NO                >YES<
```

If `yes` is selected, the uncorrected flow velocity will only be used if the flow velocity is selected as the physical quantity in the program branch `Output Options`.

All other physical quantities (volumetric flow rate, mass flow, rate etc.) will be determined with the corrected flow velocity.

During the measurement, the designation of the physical quantity will be displayed in capital letters to indicate that the value is uncorrected.

Press ENTER.

```
A:Flow Velocity
*U  54.5      m/s
```

In both cases, the corrected flow velocity can also be displayed.

Scroll with key  until the flow velocity is displayed. The uncorrected flow velocity is marked with `U`.

Uncorrected flow velocities transmitted to a PC are marked with `uncorr..`

11.6 Measurement of Transient Processes (FastFood Mode)

The FastFood mode enables the measurement of flows with high dynamics.

A continuous adaptation to changing measuring conditions which takes place in the normal measuring mode is only partially realized in the FastFood mode.

- The sound velocity of the medium is not measured. Instead, the sound velocity stored in the internal database is used, taking into account the medium temperature entered in the program branch `Parameter` (or the measured temperature if the medium temperature is measured).
- A change of measuring channel is not possible.
- The inputs and outputs can still be used.
- The measured values are stored as usual.

The FastFood mode has to be enabled and activated.

11.6.1 Enabling/Disabling the FastFood Mode

Enter HotCode 007022 immediately after the transmitter has been switched on.

```
Enable FastFood
no                >YES<
```

Select `yes` to enable the FastFood Mode, `no` to disable it.

11.6.2 Storage Rate of the FastFood Mode

Storage Rate	
70	ms

If the FastFood mode is enabled, a Storage Rate in ms will have to be entered in the program branch Output Options.

Press ENTER.

11.6.3 Activation/Deactivation of the FastFood Mode

If the FastFood mode is enabled and a measurement is started, the normal measuring mode will still be running (i.e. multi-channel measurement with permanent adaptation to the measuring conditions). If the data logger is activated, the measured values will not be stored.

A:Volume Flow	
54.5	m ³ /h

Press key **0** to activate/deactivate the FastFood mode for the measuring channel currently displayed.

A:Mode=FastFood	
54.5	m ³ /h

Scroll with key **9** in the upper line until the activated measuring mode A:Mode=FastFood or A:Mode=TransTime is displayed.

If the data logger is activated, a new data set will be created and storing of measured values will be started. If the FastFood mode is deactivated or if the measurement is interrupted, the storing will be stopped.

Note!

The values of the current measuring data set will be deleted if the FastFood mode is deactivated and activated again without interrupting the measurement.

The values of the current measuring data set will be kept if the measurement is interrupted before the FastFood mode is activated again. A new measuring data set is created when the next measurement is started.

11.7 Calculation Channels

In addition to the ultrasonic measuring channels, the transmitter has two virtual calculation channels Y and Z. The measured values of the measuring channels A and B can be used for calculations by the calculation channels.

The result of the calculation is the measured value of the selected calculation channel. This measured value is equivalent to the measured values of a measuring channel. All operations with the measured values of a measuring channel (totalizing, online output, storing, outputs, etc.) can also be done with the values of a calculation channel.

11.7.1 Characteristics of the Calculation Channels

In the program branch `Parameter`, the measuring channels to be used for the calculation and the calculation function have to be entered.

A calculation channel can not be attenuated. The damping factor has to be set separately for each of the two measuring channels.

Two cut-off flow values for each calculation channel can be defined. The cut-off flow is not based on the flow velocity as for measuring channels. Instead, it is defined in the unit of measurement of the physical quantity selected for the calculation channel. During the measurement, the calculated values are compared to the cut-off flow values and set to zero if necessary.

A calculation channel provides valid measured values if at least one measuring channel provides valid measured values.

11.7.2 Parameterization of a Calculation Channel

```
Parameter      ↕
for Channel    Y:
```

Select a calculation channel (Y or Z) in the program branch `Parameter`. Press ENTER.

```
Calculation:
Y= A - B
```

The current calculation function is displayed. Press ENTER to edit the function.

```
>CH1< funct ch2 ↕
  A      -      B
```

Three scroll lists are displayed in the upper line:

- selection of the first measuring channel (`ch1`)
- selection of the calculation function (`funct`)
- selection of the second measuring channel (`ch2`)

Select a scroll list with key `4` or `6`.

The list items are displayed in the lower line.

Scroll with key `8` and `2` through the scroll list. All measuring channels and their absolute values can be used as input channels for the calculation.

The following calculation functions are available:

- -: $Y = \text{ch1} - \text{ch2}$
- +: $Y = \text{ch1} + \text{ch2}$
- (+)/2: $Y = (\text{ch1} + \text{ch2})/2$
- |- |: $Y = |\text{ch1} - \text{ch2}|$

Press ENTER.

11.7.3 Output Options for a Calculation Channel

Output Options ↕
for Channel Y:

Select a calculation channel in the program branch Output Options. Press ENTER.

Physic. Quant. ↕
Mass Flow

Select the physical quantity to be calculated. Press ENTER.

Make sure that the physical quantity selected for the calculation channel can be calculated from the physical quantities of the selected measuring channels. Possible combinations are shown in Table 11.2.

Table 11.2: physical quantity of the calculation channel

physical quantity of the calculation channel	possible physical quantity of the first measuring channel (CH1)				possible physical quantity of the second measuring channel (CH2)			
	flow velocity	volumetric flow rate	mass flow rate	heat flow	flow velocity	volumetric flow rate	mass flow rate	heat flow
flow velocity	x	x	x	x	x	x	x	x
volumetric flow rate		x	x	x		x	x	x
mass flow rate		x	x	x		x	x	x
heat flow				x				x

example 1: The difference of the volume flow rates of the channels A and B is to be calculated.

The physical quantity of channel A and B can be the volumetric flow rate or the mass flow rate, but not the flow velocity. The physical quantities of the two measuring channels do not need to be identical (channel A = mass flow rate, channel B = volumetric flow rate).

example 2: To determine the heat flow difference, the physical quantity of the two input channels must be the heat flow.

Mass in: ↕
kg/h

Select the unit of measurement. Press ENTER.

Two cut-off flow values for each calculation channel can be defined. They are defined in the unit of measurement of the physical quantity selected for the calculation channel.

+Cut-off Flow
1.00 kg/h

All positive calculated values that are lower than the limit will be set to 0.

```
-Cut-off Flow
-2.00 kg/h
```

All negative calculated values that are greater than the limit will be set to 0.

```
Store Meas.Data
>NO< yes
```

The data logger can be activated/deactivated. Press ENTER.

11.7.4 Measuring with Calculation Channels

```
par >MEA< opt sf
Measuring
```

Select program branch *Measuring*. Press ENTER.

```
CHANN: A B >Y< Z
MEASUR ✓ ✓ ✓ .
```

Activate the necessary channels. Calculation channels are activated or deactivated in the same way as the measuring channels. Press ENTER.

```
WARNING! CHANNEL
      B: INACTIV!
```

If a measuring channel that is needed for an activated calculation channel has not been activated, a warning will be displayed. Press ENTER.

Position the transducers for all activated measuring channels. The measurement will be started automatically.

```
Y:Flow Velocity
  53.41 m/s
```

If a calculation channel is activated, the HumanMux mode (see section 10.2.2) will be selected at the beginning of the measurement and the values of the calculation channel will be displayed.

If the AutoMux mode is selected, the measured values of the measuring channels, but not the measured values of the calculation channels, will be displayed alternately.

```
Y: A - B
  53.41 m/s
```

Press key **9** to display the calculation function.

Press key **7** to display the measured values of the different channels.

11.8 Change of the Limit for the Inner Pipe Diameter

It is possible to change the lower limit of the inner pipe diameter for a given transducer type.

Enter HotCode 071001 immediately after the transmitter has been switched on.

```
DNmin Q-Sensor
  15 mm
```

Enter the lower limit of the inner pipe diameter of the displayed transducer type. Press ENTER to select the next transducer type.

Note! If a transducer is used below its recommended inner pipe diameter, a measurement might be impossible.

12 Storing and Output of Measured Values

Storing

The following data can be stored:

- date
- time
- measuring point number
- pipe parameters
- medium parameters
- transducer parameters
- sound path (reflection or diagonal mode)
- transducer distance
- damping factor
- storage rate
- physical quantity
- unit of measurement
- measured values
- totalizer values

In order to store the measured data, the data logger must be activated (see section 12.1.1).

The available data logger memory can be displayed (see section 12.5).

The storing of each measured value will be signaled acoustically. This signal can be deactivated (see section 12.4.6).

Online Output

During the measurement, the measured values will be transmitted directly to a PC (see section 12.2.2).

Offline Output

The measured values will be stored in the transmitter and later transmitted to a PC (see section 12.2.3).

12.1 Data Logger

12.1.1 Activating/Deactivating of the Data Logger

```
Output Options  ⬆
for Channel    A:
```

Select in the program branch `Output Options` the channel for which the data logger is to be activated. Press ENTER.

This display will not be indicated if the transmitter has only one measuring channel.

```
Store Meas.Data
no             >YES<
```

Press ENTER until the menu item `Store Meas.Data` is displayed.

Select `yes` to activate the data logger. Press ENTER.

12.1.2 Setting the Storage Rate

The storage rate is the frequency at which the measured values are output or stored. The storage rate will be set separately for each measuring channel.

If the storage rate is not set, the storage rate previously selected will be used.

The storage interval should be at least equal to the number of activated measuring channels, e.g. the storage interval of a channel should be min 2 s if 2 measuring channels are activated.

```
Storage Rate  ⬆
Once per 10 sec.
```

Select a storage rate or `EXTRA`. Press ENTER.

This display will only be indicated if `Store Meas.Data` and/or `Serial Output` are activated.

```
Storage Rate
1          s
```

If `EXTRA` has been selected, enter the storage rate. Press ENTER.

12.1.3 Measuring Point Number

At the beginning of the measurement, the measuring point must be identified by

- an ASCII text (e.g. `MS.PK20!`)
- digits, including point, hyphen (e.g. `18.05-06`).

The input mode is set in the program branch `Special Funct.` (see section 15.2.3).

```
A:Meas. Point No.:
  xxx (↑↓←→)
```

Enter the measuring point number. Press ENTER.

If arrows are displayed, ASCII text can be entered. If no arrows are displayed, only digits, point and hyphen can be entered.

The measuring point number and the parameters will be stored together with the measured values.

12.1.4 Measurement

```
DATA MEMORY
OVERFLOW!
```

If Output Options\Store Meas.Data has been activated and Special Funct.\SYSTEM settings\ Ringbuffer is deactivated, this error message will be displayed as soon as the data logger is full. Press ENTER.

If no other measured value output has been activated, the measurement will be stopped. If another measured value output has been activated, the measurement will be continued. Only the storing of the measured values will be stopped. The error message will be displayed periodically.

12.2 Output of the Measured Values

The measured values can be output via the serial interface. For the connection of the serial interface to the transmitter see section .

12.2.1 RS232 Interface

- output of the measured values in ASCII format
- transmission of the stored measured values by means of the program FluxData in binary format

12.2.2 Online Output

The measured values are transmitted via the serial interface to a PC directly during the measurement. If the data logger is activated, the measured values will also be stored.

- Select the program branch Output Options. Press ENTER.
- Select the channel for which the online output is to be activated. Press ENTER until the menu item Serial Output is displayed.

```
Serial Output
no                >YES<
```

Select yes to activate the online output. Press ENTER.

- Set the storage rate (see section 12.1.2).

The measuring point number will be requested when the measurement is started (see section 12.1.3).

12.2.3 Offline Output

The measured values will be transmitted from the data logger of the transmitter via the serial interface:

- to a PC by means of the program FluxData or
- to a terminal program in ASCII format

Offline Output by Means of the Program FluxData

Settings in the transmitter:

```
par mea opt >SF<
Special Funct.
```

Press BRK to select the main menu.

Further settings in the transmitter are not necessary.

settings in the program FluxData:

- Start the program FluxData on the PC.
- In the program FluxData, open the menu "Options" and select "Serial interface". Select the Default protocol and the serial port of the PC that the transmitter is connected to (e.g. COM1 in Fig. 12.1). Click on OK.



Fig. 12.1: Selection of the serial interface

- In the program FluxData, open the menu "DUT" and select "Receive Measuring values" (see Fig. 12.2). The received measuring data sets will be displayed (see Fig. 12.3).

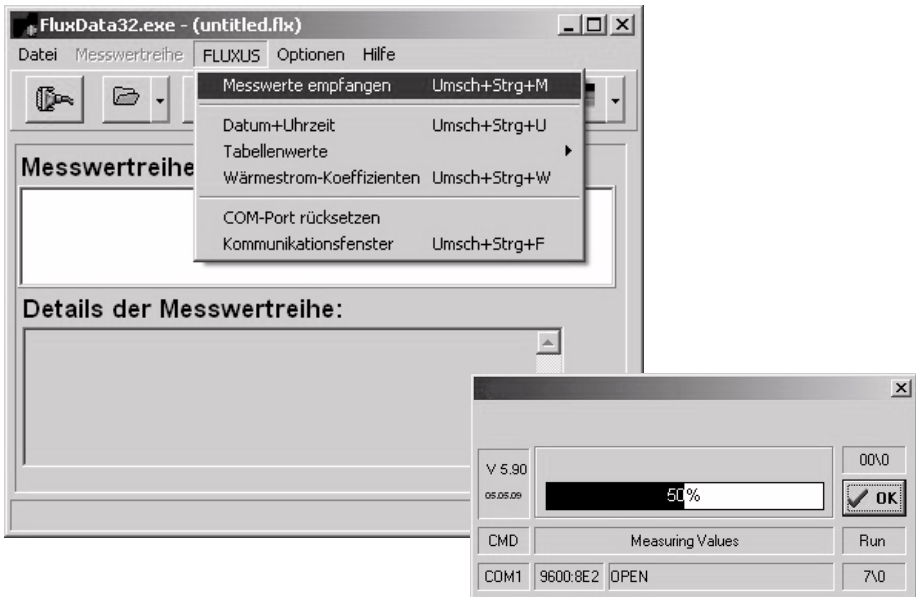

Fig. 12.2: Receive measured values

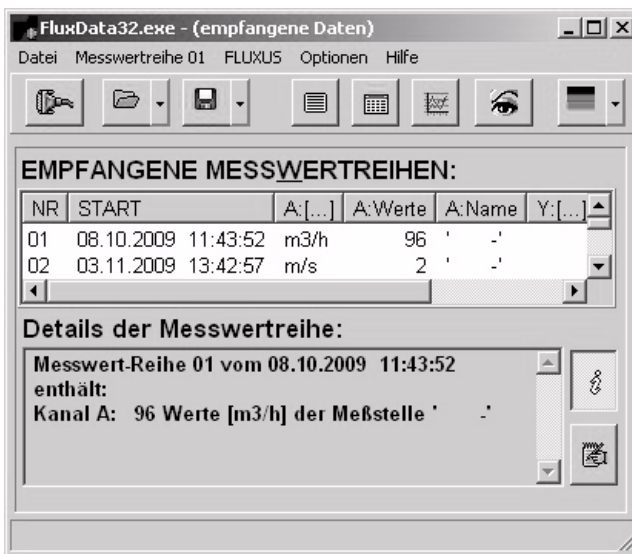

Fig. 12.3: Display of the received measuring data sets

Offline Output to a Terminal Program

```
Special Funct.  ⬆
Print Meas.Val.
```

Select Special Funct.\Print Meas.Val.. Press ENTER.

```
NO VALUES      !
Print Meas.Val.
```

This error message will be displayed if no measured values are stored. Press ENTER.

Connect the transmitter to a PC with a serial interface. Press ENTER to transmit the stored measured values.

```
Send Header    01
.....
```

The display indicates that the measured values are being transmitted.

```
SERIAL ERROR   !
Print Meas.Val.
```

This error message will be displayed if an error has occurred during the serial transmission. Press ENTER. Check the connections and make sure that the PC is ready to receive data.

```
■■■■■■■
.....
```

The progress of the data transfer is displayed by a bar graph.

12.2.4 Data Format

The header is transmitted at the beginning of the measurement. The first 4 lines contain general information about the transmitter and the measurement. The following lines contain the configuration parameters that are output for each channel in a data block.

```
example:  \DEVICE           : F601-XXXXXXXXX
          \MODE            : ONLINE
          \CHAN            : 1 (A:)
          DATE             : 2011-01-09
          TIME             : 19:56:52
          Par.Record
          Meas. Point No.: : A:F5050
          Pipe
          Outer Diameter   : 60.3 mm
          Wall Thickness    : 5.5 mm
          Roughness        : 0.1 mm
          Pipe Material    : Carbon Steel
          Lining           : WITHOUT LINING
```

```

Medium           : Water
Medium Temperat. : 38 C
Fluid pressure   : 1.00 bar
Transducer Type  : xxx
Sound Path       : 3 NUM
Transd. Distance : -15.6 mm
Damping          : 20 s
Full-Scale Val.  : 4.50 m3/h
Physic. Quant.   : Volume Flow
Unit Of Measure  : [m3/h]/[m3]

```

The line \DATA will be transmitted next, followed once by the column titles (see Table 12.1) for the corresponding channel. The measured values are transmitted afterwards.

```

example:  \DATA
          A : ; \*MEASURE;      Q_POS;          Q_NEG;
          B : ; \*MEASURE;      Q_POS;          Q_NEG;

```

In every storage interval, one data line per activated measuring channel is transmitted. The line "???" will be transmitted if there are no measured values available for the storage interval.

```

example:  With a storage interval of 1 s, 10 lines "???" will be transmitted if the
          measurement has been restarted after a 10 s interruption for the position-
          ing of the transducers.

```

The following data columns can be transmitted:

Table 12.1: Format of the serial output

column title	column format	contents
*MEASURE	###000000.00	the physical quantity selected in Output Options
Q_POS	+00000000.00	totalizer value for the positive flow direction
Q_NEG	-00000000.00	totalizer value for the negative flow direction
FQ_POS		value of the totalizer for the positive flow direction (if the heat flow has been selected as the physical quantity)
FQ_NEG		the value of the totalizer for the negative flow direction (if the heat flow has been selected as the physical quantity)
T1	###000.0	temperature T1 (= supply temperature if the heat flow has been selected as the physical quantity)

Table 12.1: Format of the serial output

T2	###000.0	temperature T2 (= return temperature if the heat flow has been selected as the physical quantity)
...		designation for other inputs
SSPEED		sound velocity of the medium
KNZ		concentration in mass percent
AMP		signal amplitude

Online Output

Columns will be created for all quantities that appear during the measurement. The columns Q_POS and Q_NEG will remain empty if the totalizers are deactivated.

As the totalizers can not be activated for the physical quantity flow velocity, these columns will not be created.

Offline Output

During the offline output, columns will only be created if at least one measured value is stored in the data set. The columns Q_POS and Q_NEG will not be created if the totalizers are deactivated.

Transmission Parameters

- the transmitter sends CRLF-terminated ASCII
- max. line length: 255 digits
- RS232: 9600 bits/s, 8 data bits, even parity, 2 stop bits, protocol (RTS/CTS)

12.2.5 Settings of the Serial Output

Some formatting settings for the serial output can be set in `Special Funct.\SYSTEM settings\serial transmis.`

```
SER:kill spaces
off >ON<
```

Select on if the space characters are not to be transmitted. Press ENTER.

The file size will be considerably smaller (shorter transmission time).

```
SER:decimalpoint
',' >'/'<
```

Select the decimal marker to be used for floating-point numbers (point or comma). Press ENTER.

```
SER:col-separat.
';' >'TAB'<
```

Select the character to be used to separate columns (semicolon or tabulator). Press ENTER.

This setting depends on the PC program used.

12.3 Deleting the Measured Values

```
Special Funct.  ⬆
Delete Meas.Val.
```

Select Special Funct.\Delete Meas.Val.. Press ENTER.

```
Really Delete?
no                >YES<
```

Select yes or no. Press ENTER.

12.4 Settings for the Data Logger

Select Special Funct.\SYSTEM settings\Storing. The following menu items are available:

- ring buffer
- storage mode
- storing of the totalizer values
- storing of the signal amplitude
- storing of the sound velocity
- storing of the concentration
- acoustic signal during the storing

12.4.1 Ring Buffer

The setting of Ringbuffer affects the storing of measured values as soon as the data logger is full:

```
Ringbuffer
off                >ON<
```

Select the behavior of the ring buffer. Press ENTER. If `on` has been selected, the available data logger memory will be halved. The oldest measured values will be overwritten. If `off` has been selected, the storing of measured values will be stopped.

12.4.2 Storage Mode

```
Storage mode
>SAMPLE< average
```

Select the storage mode. Press ENTER.

If `sample` has been selected, the displayed measured value will be used for storing and online output. If `average` is selected, the average of all values measured during a storage interval will be used for storing and online output.

Note!

The storage mode does not affect the continuously working interfaces (e.g. current output, voltage output).

If `average` has been selected, all primary physical quantities will be averaged, i.e. also the measured temperatures if the corresponding measuring channel is activated.

Note!

If no average could be calculated over the complete storage interval while average was activated, the value will be marked as invalid. The ASCII file will contain "???" instead of invalid average values and the corresponding physical quantity and "?UNDEF" instead of invalid temperatures. There will be no indication as to how many currently measured values a valid average consists of.

12.4.3 Storing of the Totalizers

It is possible to store only the value of the currently displayed totalizer or one value for each flow direction.

Select `Special Funct.\SYSTEM settings\Storing\Quantity Storage`.

```
Quantity Storage
one           >BOTH<
```

Select one to store only the displayed totalizer.

Select both to store the totalizers of both flow directions.

Press ENTER.

Note!

The totalizers will only be stored if they are activated and the data logger is activated.

The storing of a totalizer reduces the total number of measured values to be stored by approx. two thirds.

example: In the program branch `Special Funct.`, It is displayed that 10 000 additional measured values can be stored. If the totalizers are activated and only one totalizer is being stored, 3 333 data fields will be available for storing. If both totalizers are stored, 2 000 data fields will be available for storing.

12.4.4 Storing of the Signal Amplitude

Select `Special Funct.\SYSTEM settings\Storing\Store Amplitude`.

```
Store Amplitude
off           >ON<
```

If `on` is selected and the data logger is activated, the amplitude of the measured signal will be stored together with the measured values. Press ENTER.

12.4.5 Storing the Sound Velocity of the Medium

Select Special Funct.\SYSTEM settings\Storing\Store c-Medium.

```
Store c-Medium
off                >ON<
```

If on is selected and the data logger is activated, the sound velocity of the medium will be stored together with the measured values. Press ENTER.

12.4.6 Acoustic Signal

Per default, an acoustic signal will be emitted every time a measured value is stored or transmitted to a PC or printer. The signal can be deactivated in Special Funct.\SYSTEM settings\Storing\Beep on storage.

```
Beep on storage
>on<                off
```

Select off to deactivate the acoustic signal, on to activate it. Press ENTER.

12.5 Available Data Logger Memory

```
FULL= 26.01/07:39
54.5      m3/h
```

The time on which the memory will be full can be displayed during the measurement.

Scroll through the displays of the upper line with key  during the measurement.

Max. 100 measuring data sets can be stored. The number of measuring data sets depends on the total number of measured values stored in the previous measuring data sets.

If the data logger is empty and a measurement is started with one physical quantity on one measuring channel without storing the totalizer, approx. 100 000 measured values can be stored. The available data logger memory can be displayed:

```
Special Funct.  ⬆
Instrum. Inform.
```

Select Special Funct.\Instrum. Inform.. Press ENTER.

```
F601-XXXXXXXX
Free:          18327
```

The type and the serial number of the transmitter will be displayed in the upper line.

The available data logger memory will be displayed in the lower line (here: 18 327 additional measured values can be stored). Press key BRK twice to return to the main menu.

13 Working with Parameter Records

13.1 Introduction

Parameter records are data sets that contain all information necessary to perform a certain measurement task:

- pipe parameters
- transducer parameters
- medium parameters
- output options

Working with parameter records will make repeated measurement tasks easier and faster. The transmitter can store max. 14 parameter records.

Note!

No parameter records are stored in the delivery state. Parameter records are entered manually.

13.2 Storing of a Parameter Record

The parameters must first be entered in the program branch `Parameter`. Afterwards, they can be stored as a parameter record.

```
Special Funct.  ⬆
Store Curr.Rec.
```

Select `Special Funct.\Store Curr.Rec..` Press ENTER.

```
NO DATA!
Store Curr.Rec.
```

This error message will be displayed if no complete parameter record is available. Storing is impossible. Enter the missing parameters in the program branch `Parameter`.

```
Store Par. To:  ⬆
Par.Record      01
```

14 parameter records (`Par.Record 01...Par.Record 14`) can be stored. Select a parameter record. Press ENTER.

```
Overwrite
no          >YES<
```

If parameters are already stored in the selected parameter record, they can be overwritten.

Select `yes` to overwrite the parameters, or `no` to select another parameter record. Press ENTER.

13.3 Loading of a Parameter Record

Stored parameter records can be loaded and used for measurement.

```
>PAR<mea opt sf
Parameter
```

Select program branch `Parameter`. Press ENTER.

```
Parameter      ↕
for Channel    A:
```

Select the channel for which a parameter record is to be loaded. Press ENTER.

```
Parameter from: ↕
Par.Record     01
```

Select the parameter record to be loaded. Press ENTER.

```
Edit Parameters
>NO<           yes
```

Select *yes* to edit the parameters of a parameter record.
Select *no* to return to the main menu and start the measurement.

Press ENTER.

13.4 Deleting Parameter Records

```
Special Funct. ↕
Delete Para.Rec.
```

Select Special Funct.\Delete Para.Rec.. Press ENTER.

```
NO PAR. STORED! !
Delete Para.Rec.
```

This error message will be displayed if no parameter records are stored. Press ENTER.

```
Delete:        ↕
Par.Record     01
```

This display will be indicated if parameter records are stored.

Select the parameter record to be deleted. Press ENTER.

```
Really Delete?
no             >YES<
```

Confirm whether to delete the parameter record. Press ENTER.

14 Libraries

The internal material database of the transmitter contains parameters for pipe and lining materials as well as for media. It can be extended with user defined materials or media. User defined materials and media will always be displayed in the scroll lists of the program branch `Parameter`.

User defined materials and media can be stored in an integrated coefficient memory (user area). The coefficient memory has to be partitioned first (see section 14.1).

The properties of user defined materials or media can be entered as follows:

- as constants without the extended library (see section 14.2)
- as constants or temperature and pressure dependent functions by means of the extended library (see section 14.3)

The material and media scroll lists displayed in the program branch `Parameter` can be arranged (see section 14.5). Shorter scroll lists make working more efficient.

14.1 Partitioning of the Coefficient Memory

The coefficient memory can be divided into parts for the following material data:

- material properties:
 - transversal and longitudinal sound velocity
 - typical roughness
- medium properties:
 - min. and max. sound velocity
 - kinematic viscosity
 - density
- heat flow coefficients (additional medium property)
- steam coefficients (additional medium property)

For the max. number of data sets for each category of these material data see Table 14.1.

Table 14.1: Capacity of the coefficient memory

	max. number of data sets	occupancy of the coefficient memory in %
materials	13	97
media	13	97
heat flow coefficients	29	98
steam coefficients	19	95

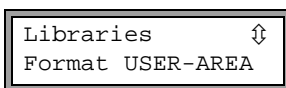

Select Special Funct.\SYSTEM settings\ Libraries\Format USER-AREA. Press ENTER.

```

MAXIMAL:      13!
Materials:    15
  
```

This error message will be displayed if the entered number of data sets for a category of material data exceeds the capacity of the coefficient memory.

```

Format USER-AREA
Materials:    03
  
```

Enter the number of the user defined materials. Press ENTER.

```

Format USER-AREA
Media:       03
  
```

Enter the number of the user defined media. Press ENTER.

```

Format USER-AREA
Heat-Coeffs: 00
  
```

Enter the number of user defined data sets for the heat flow coefficients. Press ENTER.

Heat flow coefficients can only be entered if the transmitter has temperature inputs.

```

Format USER-AREA
Steam-Coeffs: 00
  
```

Enter the number of user defined data sets for the steam coefficients. Press ENTER.

Steam coefficients can only be entered if the transmitter has temperature inputs.

```

USER AREA:
  52%      used
  
```

The occupancy of the coefficient memory is displayed for a few seconds.

```

Format NOW?
no          >YES<
  
```

Select *yes* to start the partitioning. Press ENTER.

```

FORMATTING ...
■■■■■■■ ...
  
```

The coefficient memory will be partitioned accordingly. This procedure takes a few seconds.

```

Libraries      ⇅
Format USER-AREA
  
```

After the partitioning, `Format USER-AREA` is displayed again.

14.1.1 Data Retention during Formatting of the Coefficient Memory

When the coefficient memory is repartitioned, max. 8 data sets of each type can be retained.

example 1: The number of user defined materials is reduced from 5 to 3. The data sets #01 to #03 are retained. . The data sets #04 and #05 are deleted.

example 2: The number of user defined materials is increased from 5 to 6. All 5 data sets are kept.

14.2 Input of Material/Medium Properties without the Extended Library

To enter the material/medium properties as constants, the extended library must be deactivated.

```
Libraries  ↕
Extended Library
```

Select Special Funct.\SYSTEM settings\Libraries\Extended Library. Press ENTER.

```
Extended Library
>OFF<      on
```

Select off to deactivate the extended library. Press ENTER.

The properties of a user defined material/medium can be entered now.

The input of a material or a medium is almost identical. Therefore, displays for a medium will only be shown and described in case of differences.

```
Special Funct.  ↕
Install Material
```

Select Special Funct.\Install Material or Install Medium. Press ENTER.

```
USER Material
NOT FORMATTED !
```

This error message will be displayed if the coefficient memory does not contain an area for user defined materials/media.

Partition the coefficient memory accordingly (see section 14.1).

```
Install Material
>EDIT<      delete
```

Select edit. Press ENTER.

```
USER Material  ↕
#01:--not used--
```

Select a user defined material/medium. Press ENTER.

```
EDIT TEXT (↑↓←→)
USER MATERIAL  1
```

Change the designation of the material/medium.

The default name for a user defined material/medium is USER MATERIAL N or USER Medium N with N being an integer.

Note!

95 ASCII characters (letters, capital letters, numbers, special characters [! ? " + - () > < % * etc.]) are available for the designation of materials/media.

A designation can have max. 16 characters. The input of text is described in section 3.4.

Material Properties

c-Material		
1590.0	m/s	

Enter the sound velocity of the material. Press ENTER.

For the sound velocity of some materials see annex C, Table C.1.

Roughness		
0.4	mm	

Enter the roughness of the material. Press ENTER.

For the typical roughness of some materials see annex C, Table C.2.

Medium Properties

c-Medium	MIN	
1400.0	m/s	

Enter the min. and max. sound velocity of the medium. Press ENTER.

c-Medium	MAX	
1550.0	m/s	

Kinem.Viscosity		
1.01	mm ² /s	

Enter the kinematic viscosity of the medium. Press ENTER.

Density		
1.00	g/cm ³	

Enter the density of the medium. Press ENTER.

14.3 Extended Library

14.3.1 Introduction

If the extended library is activated, it is possible to enter material and medium properties as a function of the temperature or of the pressure and additional medium properties (heat flow coefficients, steam coefficients and concentration coefficients). These data can be entered into the transmitter directly or by means of the program FluxKoeff.

Table 14.2: Material and medium properties that can be stored

property	property is necessary for...
material property	
transversal sound velocity	flow measurement
longitudinal sound velocity	flow measurement, wall thickness measurement
type of sound wave	flow measurement
typical roughness	profile correction of the flow velocity
medium property	
sound velocity	start of measurement
viscosity	profile correction of the flow velocity
density	calculation of mass flow rate
additional properties of a medium	
heat flow coefficients	heat flow measurement
steam coefficients	heat flow measurement with steam in supply line

Enter only the properties needed for the measuring task.

example: The density of a medium is unknown. If the mass flow rate is not measured, any constant value can be entered as the density.

The measurement of the flow velocity and of the volumetric flow rate will not be affected. However, the value of the mass flow rate will be wrong.

The dependency of the material/medium properties from the temperature and pressure can be described

- as constants
- as linear function
- with polynomials of grade 1 to 4
- with customized interpolation functions

In most cases, constants or a linear function are sufficient.

If e.g. the temperature fluctuations at the measuring point are low compared to the temperature dependency of the material properties, the linearization or the complete neglect of the temperature dependency will not result in a considerable additional measuring error.

If, however, the process conditions fluctuate strongly and the medium properties depend strongly on the temperature (e.g. viscosity of a hydraulic oil), polynomials or customized interpolation functions should be used. Contact FLEXIM to find the best solution for the measuring task.

Customized Interpolation Functions

Some dependencies are only approximated insufficiently by polynomials. A number of customized interpolation functions `Basics: Y=F(X,Z)` are available to interpolate multidimensional dependencies $y = f(T, p)$. Contact FLEXIM for more information.

14.3.2 Activation of the Extended Library

```
Extended Library
off                >ON<
```

Select Special Funct.\SYSTEM settings\ Libraries\Extended Library. Press ENTER.

Select on to activate the extended library. Press ENTER.

14.3.3 Input of Material/Medium Properties

The properties of a user defined material/medium can be entered now.

The input of a material or a medium is almost identical. Therefore, the displays for a medium will only be shown and described in case of differences.

```
Special Funct.  ⬆
Install Material
```

Select Special Funct.\Install Material Or Install Medium. Press ENTER.

```
USER Material
NOT FORMATTED !
```

An error message will be displayed if the coefficient memory does not contain an area for user defined materials/media.

Partition the coefficient memory accordingly (see section 14.1).

```
Edit Material  ⬆
Basics:Y=m*X +n
```

Select the function for the temperature or pressure dependency of the material/medium properties:

Y=const.: constants

Y=M*X+N: linear function of the temperature

Y=Polynom: $y = k_0 + k_1 \cdot x + k_2 \cdot x^2 + k_3 \cdot x^3 + k_4 \cdot x^4$

Y=F(X, Z): customized interpolation function (only for experienced users or after consultation with FLEXIM)

go back: return to the precedent menu item

```
USER Material  ⬆
#01:--not used--
```

Select a user defined material/medium.

```
USER MATERIAL  2
>EDIT<         delete
```

Select edit to edit the material/medium properties or delete to delete the material/medium and to return to the scroll list Edit Material or Edit Medium.

This display will only be indicated if an already existing material/medium has been selected.

```
#2: Input Name:
USER MATERIAL  2
```

Enter the designation of the material/medium. Press ENTER.

The default name for a user defined material/medium is USER MATERIAL N or USER Medium N with N being an integer.

Material Properties

Enter the material's:

- transversal sound velocity
- longitudinal sound velocity

1...5 values depending on the selected function must be entered. Press ENTER after each input.

If an already defined material is edited, for each property there will be a request whether it is to be edited. Select *yes* or *no*. Press ENTER. Change the values, if necessary.

```
Default soundsp.
long.    >TRANS.<
```

Select the type of sound wave to be used for the flow measurement. Press ENTER.

For most materials, a transversal sound wave must be selected.

```
Roughness
0.4      mm
```

Enter the typical roughness of the material. Press ENTER.

```
Save changes
no        >YES<
```

Select *yes* to store the entered properties or *no* to quit the menu item without storing. Press ENTER.

Medium Properties

Enter the medium's:

- longitudinal sound velocity
- kinematic viscosity
- density

Depending on the selected function, 1...5 values must be entered. Press ENTER after each input.

If an already defined medium is edited, for each property of some of the functions there will be a request whether it is to be edited. Select *yes* or *no*. Press ENTER. Change the values, if necessary.

```
Save changes
no        >YES<
```

Select *yes* to store the entered properties, *no* to quit the menu item without storing. Press ENTER.

14.3.4 Input of Heat Flow Coefficients

Note! The heat flow coefficients can also be edited with the programs Flux-Data and FluxKoef.

Note! The entered coefficients will not be checked. Absurd values can result in wrong measured values or in permanent system errors.

Select Special Funct.\Install Medium. Press ENTER.

```

Edit Medium      ↕
Heat-flow coeffs
    
```

Select Heat-flow coeffs. Press ENTER.

```

Heat-flow coeffs
NOT FORMATTED !
    
```

This error message will be displayed if the coefficient memory does not contain an area for the heat flow coefficients.

Partition the coefficient memory accordingly (see section 14.1).

```

Heat-Coeffs for ↕
Beer
    
```

Select the medium for which the heat flow coefficients have to be entered.

User defined media will be displayed first, followed by the media of the internal database.

```

Select index     ↕
02(--not used--)
    
```

Select an index for storing the heat flow coefficients of the selected medium. Press ENTER.

If the coefficient memory is partitioned in such way that heat flow coefficients for two media can be entered, indices 01 and 02 are available.

```

Heat-flow coeffs
      0.0 a0
    
```

Enter the 10 heat flow coefficients: a0...a4, r0...r4. Press ENTER after each input.

```

Heat-flow coeffs
Save? no      >YES<
    
```

Select yes to store the heat flow coefficients. Press ENTER.

14.3.5 Input of the Steam Coefficients

Use the program FluxKoef (optional).

Note! The entered coefficients will not be checked. Absurd values can result in wrong measured values or in permanent system errors.

14.4 Deleting a User Defined Material/Medium

To delete a user defined material/medium, proceed as follows:

Select `Special Funct.\Install Material` or `Install Medium`. Press `ENTER`.

If the extended library is activated, press `ENTER` until the request for deleting is displayed.

```
Install Material
edit      >DELETE<
```

Select `delete`. Press `ENTER`.

```
USER Material
#01: Polystyrol
```

Select the material/medium to be deleted. Press `ENTER`.

```
Really Delete?
no          >YES<
```

Select `yes` or `no`. Press `ENTER`.

14.5 Arrangement of the Material/Medium Scroll List

The materials and media to be displayed in the program branch `Parameter` are arranged in the material scroll list and in the medium scroll list.

Note!

User defined materials/media will always be displayed in the scroll lists of the program branch `Parameter`.

```
SYSTEM settings ⇅
Libraries
```

Select `Special Funct.\SYSTEM settings\Libraries`. Press `ENTER`.

```
Libraries ⇅
Material list
```

Select `Material list` to edit the material scroll list or `Medium list` to edit the medium scroll list.

Select `go back` to return to `SYSTEM settings`. Press `ENTER`.

```
Material list
factory      >USER<
```

Select `factory` if all materials/media of the internal database are to be displayed in the scroll list. An already existing scroll list will not be deleted but only deactivated.

Select `user` to activate the user defined scroll list. Press `ENTER`.

```
Material list ⇅
>Show list
```

If `user` has been selected, the material or medium scroll list can be edited (see section 14.5.1...14.5.3).

```
Material list  ⬆
>End of Edit
```

Select `End of Edit` to stop editing. Press ENTER.

```
Save List    ?
no           >YES<
```

Select `yes` to store all changes of the scroll list or `no` to quit the menu item without storing. Press ENTER.

Note! If the material/medium scroll list is quit by pressing key BRK before storing, all changes will be lost.

14.5.1 Displaying a Scroll List

```
Material list  ⬆
>Show list
```

Select `Show list`. Press ENTER to display the scroll list as in the program branch `Parameter`.

```
Current list=  ⬆
Other Material
```

The current scroll list is displayed in the lower line.

Press ENTER to return to the scroll list `Material list` or `Medium list`.

14.5.2 Adding a Material/Medium to the Scroll List

```
Material list  ⬆
>Add Material
```

Select `Add Material` or `Add Medium` to add a material/medium to the scroll list. Press ENTER.

```
>Add Material  ⬆
Stainless Steel
```

All materials/media that are not contained in the current scroll list will be displayed in the lower line.

Select the material/medium. Press ENTER. The material/medium will be added to the scroll list.

Note! The materials/media are displayed in the order in which they have been added.

14.5.3 Adding all Materials/Media to the Scroll List

```
Material list  ⬆
>Add all
```

Select `Add all` to add all materials/media of the database to the current scroll list. Press ENTER.

14.5.4 Removing a Material/Medium from the Scroll List

```
Material list  ⬆⬇
>Remove Material
```

Select `Remove Material` or `Remove Medium` to remove a material/medium from the scroll list. Press `ENTER`.

```
>Remove Material⬆⬇
Stainless Steel
```

All materials/media of the current scroll list will be displayed in the lower line.

Select the material/medium. Press `ENTER`. The material/medium will be removed from the scroll list.

Note!

User defined materials/media will always be displayed in the scroll lists of the program branch `Parameter`. They can not be removed.

14.5.5 Removing all Materials/Media from the Scroll List

```
Material list  ⬆⬇
>Remove all
```

Select `Remove all` to remove all materials/media from the scroll list. Press `ENTER`. User defined materials/media will not be removed.

15 Settings

15.1 Time and Date

The transmitter has a battery-powered clock. Measured values are automatically stored with the date and time.

15.1.1 Time

```
SYSTEM settings ⬆
Set Clock
```

Select **Special Funct.** \SYSTEM settings\Set Clock. Press ENTER.

```
TIME          11:00
ok            >NEW<
```

The current time is displayed. Select **ok** to confirm the time or **new** to set the time. Press ENTER.

```
TIME          11:00
Set Time      !
```

Select the digit to be edited with key **4** and **6**.

Edit the selected digit with key **8** and **2**. Press ENTER.

```
TIME          11:11
>OK<         new
```

The new time is displayed. Select **ok** to confirm the time or **new** to set the time again. Press ENTER.

15.1.2 Date

After the time has been set, DATE is displayed.

```
DATE 2011-01-25
ok            >NEW<
```

Select **ok** to confirm the date or **new** to set the date. Press ENTER.

```
DATE 2011-01-25
Set Date     !
```

Select the digit to be edited with key **4** and **6**.

Edit the selected digit with key **8** and **2**. Press ENTER.

```
DATE 2011-01-26
>OK<         new
```

The new date is displayed. Select **ok** to confirm the date or **new** to set the date again. Press ENTER.

15.2 Dialogs and Menus

SYSTEM settings ⬆
Dialogs/Menus

Select Special Funct.\SYSTEM settings\Dialogs/Menus. Press ENTER.

Note!

The settings of the menu item Dialogs/Menus will be stored at the end of the dialog. If the menu item is quit before the end of the dialog, the settings will not be effective.

15.2.1 Pipe circumference

Pipe Circumfer.
off >ON<

Select on if the pipe circumference is to be entered instead of the pipe diameter in the program branch Parameter. Press ENTER.

Outer Diameter
100.0 mm

If on has been selected for Pipe Circumfer., the outer pipe diameter will nevertheless be requested in the program branch Parameter.

To select the menu item Pipe Circumfer., enter 0 (zero). Press ENTER.

Pipe Circumfer.
314.2 mm

The value displayed in Pipe Circumfer. is calculated on the basis of the last displayed value of the outer pipe diameter.

example: $100 \text{ mm} * \pi = 314.2 \text{ mm}$

Pipe Circumfer.
180 mm

Enter the pipe circumference. The limits for the pipe circumference are calculated on the basis of the limits for the outer pipe diameter.

Outer Diameter
57.3 mm

During the next scroll through the program branch Parameter, the outer pipe diameter that corresponds to the entered pipe circumference will be displayed.

example: $180 \text{ mm} : \pi = 57.3 \text{ mm}$

Note!

The pipe circumference is only edited temporarily. When the transmitter switches back to the display of the pipe circumference (internal recalculation), slight rounding errors may occur.

example: entered pipe circumference: 100 mm
displayed outer pipe diameter: 31.8 mm

When the transmitter switches back to the display of the pipe circumference, 99.9 mm will be displayed.

15.2.2 Medium Pressure

The dependency of the properties of a medium on the pressure can be taken into account.

```
Fluid pressure
off                >ON<
```

If `on` has been selected, the medium pressure will be requested in the program branch `Parameter`.

If `off` has been selected, 1 bar will be used for all calculations.

Note!

For documentation purposes, it is useful to enter the medium pressure, even if the transmitter contains no pressure-dependent characteristic curves.

15.2.3 Measuring Point Number

```
Meas. Point No.:
(1234) >(↑↓←→)<
```

Select `1234` if the measuring point is to be identified only by numbers, point and dash.

Select `↑↓←→` if the measuring point is to be identified by the ASCII editor.

15.2.4 Transducer Distance

```
Transd. Distance
auto                >USER<
```

recommended setting: `user`

- `user` will be selected if the measuring point is always the same.
- `auto` can be selected if the measuring point changes often.

```
Transd. Distance?
(50.8) 50.0 mm
```

In the program branch `Measuring`, the recommended transducer distance will be displayed in parentheses, followed by the entered transducer distance if the recommended and the entered transducer distance are not identical.

```
Transd. Distance?
50.8 mm
```

During transducer positioning in the program branch `Measuring`

- only the entered transducer distance will be displayed if `Transd. Distance = user` has been selected and the recommended and the entered transducer distances are identical
- only the recommended transducer distance will be displayed if `Transd. Distance = auto` has been selected.

15.2.5 Steam in the Supply Line

```
Steam in inlet
off           >ON<
```

Select `on` if the medium in the supply line can be vaporous during the heat flow measurement (see section 19.5). In this case, the supply pressure will have to be entered in the program branch `Parameter`.

15.2.6 Time-Programmable Measurement

```
Time-progr.Meas.
off           >ON<
```

Select `on` to enable `Time-progr.Meas.`, `off` to disable it.

15.2.7 Temperature Correction

```
Corr.Offset
off           >ON<
```

Select `on` to enable the input of a temperature correction for each temperature input (see section 20.5).

15.2.8 Error Value Delay

The error value delay is the time after which an error value will be sent to an output if no valid measured values are available.

```
Error-val. delay
damping      >EDIT<
```

Select `edit` to enter an error value delay. Select `damping` if the damping factor is to be used as the error value delay.

For further information on the behavior of missing measured values see section 21.1.2 and 21.2.

15.2.9 Alarm State Indication

```
SHOW RELAIS STAT
off           >ON<
```

Select `on` to display the alarm state during the measurement.

Fur further information on the alarm outputs see section 21.6.

15.2.10 Preferred Units

It is possible to set the preferred units for the length, temperature and pressure:

```
Length unit
>[mm]<      [inch]
```

Select `mm` or `inch` as the preferred unit for the length. Press `ENTER`.

```
Temperature
>[°C]<      [°F]
```

Select `°C` or `°F` as the preferred unit for the temperature. Press `ENTER`.

```
Pressure
>[bar]<    [psi]
```

Select `bar` or `psi` as the preferred unit for the pressure. Press ENTER.

15.2.11 Setting for the Medium Pressure

It is possible to set whether the absolute or the relative pressure will be used:

```
Pressure absolut
off                >ON<
```

Select `on` or `off`. Press ENTER.

If `on` has been selected, the absolute pressure p_a will be displayed/input/output.

If `off` has been selected, the relative pressure p_g will be displayed/input/output.

$$p_g = p_a - 1.01 \text{ bar}$$

```
Fluid pressure
1.00 bar(a)
```

The pressure and its unit of measurement will e.g. be displayed in the program branch `Parameter`. It will be followed by the selected pressure, indicated in parentheses.

a - absolute pressure

g - relative pressure

Note! All changes will be stored at the end of the dialog.

15.3 Measurement Settings

```
SYSTEM settings ⚡
Measuring
```

Select `Special Funct.\SYSTEM settings\Measuring`. Press ENTER.

Note! The settings of the menu item `Measuring` will be stored at the end of the dialog. If the menu item is quit before the end of the dialog, the settings will not be effective.

```
WaveInjector
off                >ON<
```

This menu item will only be displayed if a `WaveInjector` is in the scope of supply (see user manual of the `WaveInjector`).

```
Compare c-fluid
no                >YES<
```

Select `yes` if the measured sound velocity is to be compared to the theoretical or expected value. The difference

$$\Delta c = c_{\text{mea}} - c_{\text{stored}}$$

between the two sound velocities will be displayed during the measurement. c_{stored} is the sound velocity stored in the database.

Press key  during the measurement to scroll to the display of Δc .

```
Flow Velocity
>NORMAL<  uncorr.
```

Select `normal` to display and output the profile corrected flow values, `uncorr.` to display and output the flow values without flow profile correction. Press ENTER.

For further information see section 11.5.

```
Cut-off Flow
absolut   >SIGN<
```

A lower limit for the flow velocity can be entered (see section 11.4).

```
Cut-off Flow
factory   >USER<
```

```
Velocity limit
24.0     m/s
```

An upper limit for the flow velocity can be entered (see section 11.3).

Enter 0 (zero) to deactivate the flow velocity check.

```
Heat Quantity
>[J]<     [Wh]
```

The heat quantity is the totalizer of the heat flow. Select the unit of measurement for the heat flow (J or Wh).

```
heat+flow quant.
off       >ON<
```

Select `on` to store and output the values of the heat quantity totalizer and the volume totalizer during the heat flow measurement.

```
Quant. wrapping
off       >ON<
```

Select the overflow behavior of the totalizers (see section 11.2.2).

```
Quantity recall
off       >ON<
```

Select `on` to keep the previous totalizer values after a restart of the measurement.

Select `off` to reset the totalizers to zero after a restart of the measurement.

```
Turbulence mode
off       >ON<
```

The activation of the turbulence mode can improve the signal quality if the flow is highly turbulent (e.g. in the vicinity of an elbow or valve). An SNR value of min. 6 dB is required during the measurement.

Note!

All changes will be stored at the end of the dialog.

15.4 Setting the Contrast

```
SYSTEM settings ⬆
Miscellaneous
```

```
SETUP DISPLAY
← CONTRAST →
```

Select Special Funct.\SYSTEM settings\ Miscellaneous to set the contrast of the display of the transmitter. Press ENTER.

The contrast of the display is adjusted with the following keys:

6  to increase the contrast

4  to decrease the contrast

2  = min. contrast

5  = medium contrast

8  = max. contrast

Note! After a cold start, the display will be reset to medium contrast.

15.5 Instrument Information

```
Special Funct. ⬆
Instrum. Inform.
```

```
F601-XXXXXXXX
Free: 18327
```

Select Special Funct.\Instrum. Inform. to display information about the transmitter. Press ENTER.

The type and the serial number of the transmitter will be displayed in the upper line.

The available data logger memory will be displayed in the lower line (here: 18 327 additional measured values can be stored).

Press ENTER.

```
F601-XXXXXXXX
V x.xx dd.mm.yy
```

The type and the serial number of the transmitter will be displayed in the upper line.

The firmware version of the transmitter with date is displayed in the lower line.

Press ENTER.

16 SuperUser-Mode

The SuperUser mode offers the possibility of an advanced analysis of the signal and the measured values as well as the definition of additional parameters adapted to the measuring point, in order to achieve better measuring values or during experimental work. Features of the SuperUser mode are:

- Defaults will not be observed.
- There are no plausibility checks when parameters are being entered.
- There is no check whether the entered parameters are within the limits determined by the laws of physics and technical data.
- The cut-off flow is not active.
- A value for the number of sound paths must be entered.
- Some menu items that are not visible in the normal the normal mode are displayed.

Attention! The SuperUser mode is intended for experienced users with advanced application knowledge. The parameters can affect the normal measuring mode and lead to wrong measuring values or to a failure of the measurement when a new measuring point is set up.

16.1 Activating/Deactivating

Enter HotCode 071049 immediately after the transmitter has been switched on .

SUPERUSER MODE
IS ACTIVE NOW

It is displayed that the SuperUser mode is activated. Press ENTER. The main menu will be displayed.

The SuperUser mode is deactivated by switching off the transmitter.

Attention! Some of the defined parameters are still active after the deactivation of the SuperUser mode.

16.2 Transducer Parameters

In the SuperUser mode, the menu item `Transducer Type` will be displayed at the end of the parameter input, even if the transducers are detected by the transmitter.

Transducer Type ⇅
Q2E-314

Press ENTER.

or

Transducer Type ⇅
Special Version

Select `Special Version` to enter the transducer parameters. Press ENTER.

```
Transd. Data    1
    35.99
```

If Special Version has been selected, the transducer parameters must be entered.

The transducer parameters must be provided by the transducer manufacturer. Press ENTER after each input.

16.3 Defining the Flow Parameters

In the SuperUser mode, it is possible to define some flow parameters (profile bounds, correction of the flow velocity) for the specific application or measuring point.

```
Measuring      ↕
Calibration
```

Select Special Funct.\SYSTEM settings\Measuring\Calibration. Press ENTER.

```
Calibrat. data ↕
for Channel    A:
```

Select the measuring channel for which the flow parameters are to be defined. Press ENTER.

16.3.1 Profile Bounds

```
A:Profile bounds
factory >USER<
```

Select user if the profile bounds are to be defined. If factory is selected, the default profile bounds will be used and the menu item Calibration will be displayed (see section 16.3.2).

Press ENTER.

```
Laminar flow
if R*<      0
```

Enter the max. Reynolds number at which the flow is laminar. The entered number will be rounded to the hundreds. Enter 0 (zero) to use the default value.

range: 0...25 500

default: 1 000

Press ENTER.

```
Turbulent flow
if R*>      0
```

Enter the min. Reynolds number at which the flow is turbulent. The entered number will be rounded to the hundreds. Enter 0 (zero) to use the default value.

range: 0...25 500

default: 3 000

Press ENTER.

```
A:Calibration ?
>OFF<          on
```

A request is displayed if an additional correction of the flow velocity is to be defined. Select `on` to define the correction data, `off` to work without correction of the flow velocity and return to the menu item `SYSTEM settings`.

For the definition of the correction of the flow velocity see section 16.3.2.

example: profile bound for the laminar flow: 1 500
profile bound for the turbulent flow: 2 500

At Reynolds numbers $< 1\,500$, the flow during the measurement is regarded as laminar for the calculation of the physical quantity. At Reynolds numbers $> 2\,500$, the flow is regarded as turbulent. The range $1\,500 \dots 2\,500$ is the transition range between laminar and turbulent flow.

Attention! The defined profile bounds are still active after the deactivation of the SuperUser mode.

16.3.2 Correction of the Flow Velocity

After the profile bounds have been defined (see section 16.3.1), it is possible to define a correction of the flow velocity.

$$v_{\text{cor}} = m \cdot v + n$$

with

- v - measured flow velocity
- m - slope, range: $-2.000 \dots +2.000$
- n - offset, range: $-12.7 \dots +12.7$ cm/s
- v_{cor} - corrected flow velocity

All quantities derived from the flow velocity will be calculated with the corrected flow velocity. The correction data are part of the parameter record and will be transmitted to the PC or printer during the online or offline output.

Note! During the measurement, it will not be displayed that the correction of the flow velocity is active.

```
A:Calibration ?
off          >ON<
```

Select `on` to define the correction data, `off` to work without correction of the flow velocity and return to the menu item `SYSTEM settings`.

```
A:Slope=
  1.00
```

If **on** has been selected, enter the slope. If 0.0 is entered, the correction will be deactivated.

range: -2.000...+2.000

Press ENTER.

```
A:Offset=
  0.0   cm/s
```

Enter the offset. Enter 0 (zero) to work without an offset.

range: -12.7...+12.7 cm/s

Press ENTER.

example 1: Slope: 1.1
Offset: -10.0 cm/s = -0.1 m/s

If a flow velocity $v = 5$ m/s is measured, before the calculation of the derived quantities, it will be corrected as follows:

$$v_{\text{cor}} = 1.1 \cdot 5 \text{ m/s} - 0.1 \text{ m/s} = 5.4 \text{ m/s}$$

example 2: Slope: -1.0
Offset: 0.0

Only the sign of the measured values is changed.

Note!

The correction data will only be stored when a measurement is started. If the transmitter is switched off without starting a measurement, the entered correction data will be lost.

Attention!

The correction of the flow velocity is still active after the deactivation of the SuperUser mode.

16.4 Limit of the Signal Amplification

In order to prevent disturbing and/or pipe wall signals (e.g. if the pipe has run empty) from being interpreted as useful signals, it is possible to define a max. signal amplification. If the signal amplification is greater than the max. signal amplification,

- the flow velocity will be marked as invalid. The physical quantity can not be determined.
- the LED of the measuring channel will light red
- a hash symbol "#" will be displayed after the unit of measurement (in case of a normal error, "?" is displayed).

Select **Special Funct./SYSTEM settings/Measuring/Miscellaneous**. Press ENTER until the menu item **Gain threshold** is displayed.

```
A: Gain threshold
Fail if > 90 dB
```

Enter for each measuring channel the max. signal amplification. Enter 0 (zero) if no limit of the signal amplification is to be used.

range: 0...255

Press ENTER.

Attention! The limit of the signal amplification is still active after the deactivation of the SuperUser mode.

16.5 Upper Limit of the Sound Velocity

When the plausibility of the signal is evaluated, it will be checked if the sound velocity is within a defined range. The upper limit used for the evaluation is the greater of the following values:

- fixed upper value, default: 1 848 m/s
- value of the sound velocity curve of the medium at the operating point plus offset, default offset: 300 m/s

In the SuperUser mode, the values can be defined for media that are not contained in the data set of the transmitter. Select `Special Funct.\SYSTEM settingsMeasuring\Miscellaneous`. Press ENTER until the menu item `Bad soundspeed` is displayed.

```
A: Bad soundspeed
thresh. 2007 m/s
```

Enter for each measuring channel the fixed upper level of the sound velocity. Enter 0 (zero) to use the default value.

range: 0...3 000 m/s

default: 1 848 m/s

Press ENTER.

```
A: Bad soundspeed
offset: +321 m/s
```

Enter for each measuring channel the offset. Enter 0 (zero) to use the default value.

range: 0...900 m/s

default: 300 m/s

Press ENTER.

example: fixed upper value of the sound velocity `thresh.:` 2 007 m/s
`offset:` 600 m/s
value of the sound velocity curve at the operating point: 1 546 m/s

As $1\,546\text{ m/s} + 600\text{ m/s} = 2\,146\text{ m/s}$ is greater than the fixed upper value 2 007, this value will be used as the upper limit of the sound velocity when the plausibility of the signal is evaluated.

GAIN=91dB SS=1038/2146 m/s

It is possible to display the valid range for the sound velocity (SS=) in the lower line during the measurement. The second value (here: 2 146 m/s) is the upper limit at the operating point.

Attention!	The defined upper limit of the sound velocity is still active after the deactivation of the SuperUser mode.
-------------------	---

16.6 Number of Decimal Places of the Totalizers

The values of the totalizers can be displayed with up to 11 places, e.g. 74890046.03. In the SuperUser mode, it is possible to define the number of decimal places.

Select Special Funct. \SYSTEM settings\Measuring\Miscellaneous. Press ENTER until the menu item Total digits is displayed.

Total digits 
Automatic

Select one of the following list items.

Automatic: dynamic adjustment
Fixed to x digit: x decimal places (range: 0...4)

Press ENTER.

Total digits = Automatic

The number of decimal places will be adjusted dynamically. Low values will first be displayed with 3 decimal places. With greater values, the number of decimal places will be reduced.

max. value	display
$< 10^6$	$\pm 0.00 \dots \pm 999999.999$
$< 10^7$	$\pm 1000000.00 \dots \pm 9999999.99$
$< 10^8$	$\pm 10000000.0 \dots \pm 99999999.9$
$< 10^{10}$	$\pm 1000000000 \dots \pm 9999999999$

Total digits = Fixed to x digit

The number of decimal points is constant. The max value of the totalizer is reduced with each additional decimal place.

decimal places	max. value	max. display
0	$< 10^{10}$	± 9999999999
1	$< 10^8$	± 99999999.9
2	$< 10^7$	± 9999999.99
3	$< 10^6$	± 999999.999
4	$< 10^5$	± 99999.9999

Note!	The number of decimal places and the max. value defined here only affect the display of the totalizers.
--------------	---

For setting the behavior of the totalizers when the max. value is reached see section 11.2.2.

16.7 Temperature-Based Heat Flow Cut-Off

With the temperature-based heat flow cut-off, all measured temperature differences between the supply and return line that are lower than a defined value are set to zero. The heat flow is also set to zero. The value of the heat quantity totalizer remains unchanged.

Select Special Funct. \SYSTEM settings\Measuring\Miscellaneous. Press ENTER until the menu item Thermal low cut is displayed.

```
Thermal low cut
off                >ON<
```

Select on to activate the temperature-based heat flow cut-off, off to deactivate it. Press ENTER.

```
Thermal flow ->0
if |dT|< 0.0 C
```

If on has been selected, enter the limit of the temperature difference. All temperature differences between the supply and return line that are lower than this value will be set to zero. Enter 0 (zero) to work without the temperature-based heat flow cut-off.

range: 0...5.0 °C

Press ENTER.

16.8 Manual Reset of the Totalizers

If the manual reset of the totalizers is activated, the totalizers can be reset to zero during the measurement by pressing key C three times.

Select Special Funct. \SYSTEM settings\Measuring\Miscellaneous. Press ENTER until the menu item 3xC clear totals is displayed.

```
3xC clear totals
off                >ON<
```

Select on to activate the manual reset of the totalizers, off to deactivate it. Press ENTER.

Note!

The manual reset of the totalizers is still active after the deactivation of the SuperUser mode.

16.9 Display of the Sum of the Totalizers

The sum of the totalizers for the two flow directions can be displayed in the upper line during the measurement.

Select Special Funct.\SYSTEM settings\Measuring\Miscellaneous. Press ENTER until the menu item Show ΣQ is displayed.

```

Show  $\Sigma Q$ 
off                >ON<
  
```

Select on to activate the display of the sum of the totalizers, off to deactivate it. Press ENTER.

```

 $\Sigma Q$           13.2 m3
  
```

If the display of the sum of the totalizers is activated, the sum ΣQ can be displayed in the upper line during the measurement.

16.10 Display During the Measurement

In the SuperUser mode, the following information can be displayed during the measurement besides the normal information (see section 10.3):

- absolute transit time of the measuring signal
- sound velocity
- Reynolds number
- variance of the measuring signal
- range of the sound velocity
- signal amplification
- SCNR value

17 Time-Programmable Measurement (Optional)

The beginning and the end of a measurement are programmed in the Time-Programmable Measurement mode. The measurement, storing and output of the measured values will be started automatically when the programmed start time is reached and stopped when the programmed stop time is reached.

The measured values can be stored with a high storage rate at a particular time (instead of being stored continuously with a low storage rate).

17.1 Activating/Deactivating

The Time-Programmable Measurement mode can be enabled and disabled in the program branch `Special Funct.\SYSTEM settings/Dialogs/Menu`.

```
Time-progr.Meas.
off                >ON<
```

Select the menu item `Time-progr.Meas.`. Select `on` to enable the Time-Programmable Measurement mode, `off` to disable it.

17.2 Input of the Start Time



```
Time-progr.Meas.
no                >YES<
```

Select `yes` in `Measuring\Time-progr.Meas.`, to program the start time. Press ENTER.

```
START:           04:15
Set Time
```

This menu item will only be displayed if the data logger, the serial output or an output has been activated.

Select the character to be edited with key  **4** and  **6**.

Set the hours and minutes with key  **2** and  **8**.

Press ENTER.

```
START:           24:15
INVALID TIME ! !
```

An error message will be displayed if an invalid time is entered.

The start time must be set between 00:00 and 23:59. Press ENTER to return to the menu item `Set Time`.

Note!

The internal clock of the transmitter works in the 24-hour mode. The time has to be entered accordingly, e.g. 02:35 p.m. = 14:35.

If a valid start time has been entered, the menu item for setting the start date will be displayed.

```
START: 2011-01-25
Set Date
```

Set the day, the month and the year. Press ENTER.

If the entered date exists and is in the future, the stop time can be entered (see section 17.3).

```
START: 39.01.2011
INVALID DATE !
```

An error message is displayed if the entered date does not exist (leap years are recognized).

Press ENTER to return to the menu item `Set Date`.

```
2011-01-25/04:15
INVALID START!
```

This error message will be displayed if the entered start time is in the past.

Press ENTER.

Note!

The seconds of the start time are automatically set to zero. Therefore, the entered start time must be at least one minute later than the current time.

```
*=25.01.11/15:17
=25.01.11/04:15
```

The current time is displayed in the upper line (*=) and the programmed start time in the lower line (↑=).

The programmed start time is invalid in this display because it is in the past (↑=).

```
*=25.01.11/15:17
* :- 11h:02m:23s
```

The display in the lower line can be toggled between the start time and the difference between the start time and the current time (*↑: -) by pressing key **9** or **3**.

Press ENTER to return to the menu item `Set Time`.

17.3 Input of the Stop Time

A time-programmable measurement can be stopped automatically. Shortly afterwards, the transmitter will be switched off if it is in battery mode. The menu item `Stop measuring` will be displayed after the input of the start time.

```
Stop measuring ⇅
Don't stop
```

Select a list item (see Table 17.1). Press ENTER.

Table 17.1: List items for the automatic stop of the measurement

list item	result
Don't stop	The measurement will not be stopped automatically unless <ul style="list-style-type: none"> • the battery is empty or • the data logger is full and no other measured value output has been selected.
STOP: Date/Time	Date and time of the automatic stop of the measurement can be set.
STOP: duration	The measurement duration can be set. The stop time will be calculated internally (START + DURATION = STOP).

Note! The battery battery will be reduced by 2 % with every hour waiting for the start time. The operating time left for the measurement will be reduced accordingly.

17.3.1 Date/Time

If the list item STOP: Date/Time has been selected in the previous step, the stop time (date and time) will be entered in the same way as the start time. Press ENTER after each input.

The validity of the entered date and time will be checked. No stop time can be entered that is before the start time.

```
=26.01.11/04:15
↓=26.01.11/08:15
```

If a valid stop time has been entered, the start time (↑=) and the stop time (↓=) will be displayed again.

example: The measurement is started on 2011-01-26 at 4:15, lasts for 4 h and is automatically stopped at 8:15.

```
=26.01.11/04:15
↓: 04h:00m:00s
```

The display in the lower line can be changed between the stop time and the measurement duration (↑↓:) by pressing key **9** or **3**.

Press ENTER to select the next menu item of the program branch Measuring.

17.4 Measurement Duration

```
:04h:00m
Set duration
```

If the list item STOP: duration has been selected in the previous step, enter the measurement duration in the same way as the start time.

The max. measurement duration is 999 h and 59 min, corresponds to approx. 41 days.

Press ENTER.

```
=26.01.11/04:15
↓=26.01.11/08:15
```

The start time (↑=) and the stop time (↓=) calculated from the entered measurement duration is displayed.

```
=26.01.11/04:15
↓: 04h:00m:00s
```

The display in the lower line can be toggled between the stop time and the measurement duration (↑↓:) by pressing key **9** or **3**.

Press any key (but BRK) to select the next list item of the scroll list *Measuring*.

17.5 Measuring in the Time-Programmable Measurement Mode

If the Time-Programmable Measurement mode is activated, the output options are defined and the start and stop time are set, proceed as follows:

- Start the measurement as usual. The current measured values are displayed, stored and/or transmitted depending on the selected measured value output.
- Activate all settings necessary for the time-programmable measurement (e.g. totalizers).
- Press ENTER to start the countdown. The current measurement will be interrupted and the countdown started.

Note! The countdown can be stopped by pressing key BRK.

The memory required for the measurement can now be calculated.

If a stop time or a measurement duration has been set and the data logger is activated, it will be checked whether the available data logger capacity is sufficient for the storage of the measured values during the complete measurement duration.

If it is not sufficient, the following error message will be displayed:

```
: MAX 85%
Store Meas.Data
```

In the example, the available data logger capacity is enough for only 85 % of the expected measured values.

```
FULL= 26.01/07:39
Store Meas.Data
```

Press key **9** or **3** to display the time at which the memory is expected to be full in the upper line.

If storing is the only active measured value output, the measurement will be stopped as soon as the data logger is full, even if the stop time has not been reached yet.

If another measured value output is activated, the measurement will be continued until the defined stop time, even if the data logger is full. If the available data logger capacity is not enough, proceed as follows:

- Delete all stored measured values in the menu item *Special Funct.\Delete Meas.Val..*

- Increase the value in `Output Options\Storage Rate`. If the storage interval is doubled, the required capacity is halved, e.g. from `Every Second` to every 2 seconds (set in list item `EXTRA`).
- If possible, deactivate the totalizers. The storing of one totalizer value triples the required capacity.
- Check the storage mode of the totalizer. If it is sufficient to store the totalizer of one flow direction only, select the list item `one` in `Special Funct.\SYSTEM settings\Storing\Quantity Storage`.

The Countdown

```
WAIT TO START AT
26.01. /04:15:00
```

It is indicated that the countdown is running. The current status (waiting for the start time) or the current time is displayed in the upper line.

```
25.01. /15:18:44
26.01. /04:15:00
```

The display in the lower line can be toggled between the start time and the remaining time until the measurement is started (*↑:.) with key **3** DISP.

During the countdown, it is possible to check if a stop time has been programmed. Press key **9** STOP to display further information in the upper line.

```
NO STOP DEFINED
```

This message will be displayed if no stop time has been programmed.

```
STOP MEASURE AT
26.01. /08:15:00
```

This message indicates that the measurement will be stopped automatically at the displayed time.

```
25.01 /15:18:46
↓: 04h:00m:00s
```

Press key **3** DISP to display the stop time or the measurement duration (↑↓:).

Measurement

When the start time is reached, the previously interrupted measurement will be continued. During the measurement, it is possible to check if a stop time has been programmed.

```
A:Volume Flow
54.5 m3/h
```

Press key **9** STOP once or several times during the measurement.

```
*↓ = 03h:58m:17s
54.5 m3/h
```

Additional information is displayed in the upper line, e.g. the time remaining until the automatic stop of the measurement(*↓:).

If this message is missing, no stop time has been programmed.

Note!

The measurement will be interrupted by pressing key BRK.

The time-programmable measurement will be stopped automatically if:

- the stop time is reached
- the data logger is full and no other measured value output is activated
- the battery is empty

17.6 Storing Measured Values

If the data logger is activated, the measured values will be stored after the start of the measurement. The stored values will be kept if the measurement is interrupted (key BRK) to start or interrupt the countdown.

However, when the measurement is started automatically after the countdown, all measured values stored before the countdown will be deleted. The first measured value stored after the automatic start will be the first value of the current measuring data set. The start time will be stored as reference for the current measuring data set.

17.7 Online Output

If the online output via the serial interface is activated, the header will be transmitted or printed at the start of the measurement. As long as the countdown has not started, the current measured values and totalizer values will be output.

When the countdown is started, a message will be displayed that the start time is waited for. The measurement will be stopped.

When the start time is reached, date, time and measuring point number will be transmitted or printed.

After the character sequence `\DATA`, the measured values will be printed as usual.

If the transmitter is operated with a battery and the battery has been discharged completely during the countdown or measurement, the error message `\LOWBAT 29.04. / 01:30` will be displayed.

An automatic stop of the measurement when the programmed stop time is reached is displayed as follows: `\STOP MEASURE AT: 30.04. /08:15:00`.

18 Wall Thickness Measurement (Optional)

If the transmitter has the optional wall thickness measurement, the wall thickness and the longitudinal sound velocity of the pipe can be measured. In this case, a wall thickness probe that can be connected directly to the socket of a measuring channel will be included in shipment. The wall thickness probe will be detected automatically when connected to the transmitter. The measured wall thickness can be transmitted directly into the current parameter record.

A modified transit time method is used to determine the wall thickness or the sound velocity of the pipe.

- The wall thickness probe emits an ultrasonic pulse which propagates in the pipe.
- The pulse is reflected by the boundary layer of the pipe and received by the wall thickness probe.
- The time difference between emitting and receiving the signal is a measure of the pipe wall thickness (if the sound velocity of the material is known) or of the longitudinal sound velocity (if the wall thickness is known).

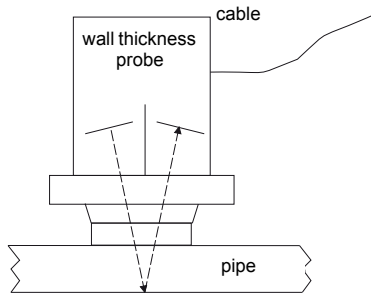

Fig. 18.1: Measurement principle

Note!

With some few exceptions, the transversal sound velocity of a material is approx. 30...60 % of the longitudinal sound velocity.

18.1 Activation of the Wall Thickness Measurement

Connect the wall thickness probe to the measuring channel A or B. The wall thickness measuring mode is activated automatically.

```
*WALL THICKNESS*
*DETECTED ON A:*
```

A message is displayed that the wall thickness probe has been detected.

The main menu of the wall thickness measurement is displayed. The menu structure is similar to the structure of the flow measurement. The program branches are adapted to the wall thickness measurement.

Note!

The wall thickness measurement mode will be activated as long as the wall thickness probe is connected to the measuring channel.

18.2 Parameter Input

18.2.1 Parameter Input for the Wall Thickness Measurement

The sound velocity of the pipe material has to be entered to measure the wall thickness.

Physic. Quant. ⬆
Wall Thickness

Select `Wall Thickness` in `Output Options\Physic. Quant.` for the measuring channel to which the wall thickness probe is connected.

Pipe Material ⬆
Carbon Steel

Select the pipe material in `Parameter\Pipe Material`. If the material is not in the scroll list, select `Other Material`.

Press ENTER.

c-LONGITUDINAL
5800.0 m/s

A value for the longitudinal sound velocity of the selected material is recommended.

If `Other Material` has been chosen, 0.0 m/s will be displayed.

Enter the sound velocity, if necessary. Press ENTER.

Note!

The measurement can only be started if the entered sound velocity is > 0 .

Compared to the flow measurement, the sound velocity has a great, approximately linear influence on the measuring result. If a sound velocity that is 10 % too high is entered, the measured wall thickness will be approx. 10 % greater than the actual wall thickness.

The actual sound velocity of a material often differs substantially from the values published in the literature as it depends on the composition, the manufacturing process and the temperature. The sound velocities given in annex C, Table C.1 only serve as an orientation.

Note!

The longitudinal sound velocity of a material can be measured precisely using a reference object of known thickness (see section 18.3.2).

18.2.2 Parameter Input for the Sound Velocity Measurement

The thickness of the pipe must be entered to determine the longitudinal sound velocity of a material.

```
Physic. Quant.  ⬆
c-LONGITUDINAL
```

Select in Output Options\Physic. Quant. the physical quantity c-LONGITUDINAL for the measuring channel to which the wall thickness probe is connected.

```
Wall Thickness
5.12      mm
```

Select Parameter\Wall Thickness. Enter the pipe wall thickness.

18.3 Measurement

```
par >MEA< opt sf
Measuring
```

Select in the main menu the program branch Measuring. Press ENTER.

```
par >MEA< opt sf
NO DATA!
```

This error message will be displayed if the entered parameters are not complete.

18.3.1 Measurement of the Wall Thickness

```
Wall Thickness
mm?
```

This display is indicated if the wall thickness has been selected as the physical quantity for the measuring channel connected to the probe.

As long as there is no valid measured value, the unit of measurement and a question mark will be displayed in the lower line.

```
Wall Thickness  ✓
3.51      mm
```

Apply a thin film of the coupling compound to the pipe wall. Press the wall thickness probe against the pipe wall in this position.

As soon as a valid measured value is obtained, it will be displayed in the lower line. A tick will be displayed in the upper line on the right.

The measured value remains on the display when the probe is removed from the pipe.

To minimize errors when measuring the wall thickness, measure the longitudinal sound velocity of the material on a reference object of the same material with known dimensions.

- The reference object should be even and smooth.
- The thickness of the reference object should be comparable to the max. thickness of the pipe.

Note!

The sound velocity of the material depends on the temperature. Therefore, the sound velocity of a reference object should be measured at the place where the flow will be measured later to obtain the sound velocity at the correct temperature.

18.3.2 Measurement of the Sound Velocity

c-LONGITUDINAL
m/s?

This display will be indicated if the sound velocity has been selected as physical quantity for the measuring channel connected to the wall thickness probe.

As long as there is no valid measured value, the unit of measurement and a question mark will be displayed in the lower line.

c-LONGITUDINAL ✓
5370 m/s

Apply a thin film of the coupling compound to the pipe wall. Press the wall thickness probe against the pipe wall in this position.

As soon as a valid measured value is obtained, it will be displayed in the lower line. A tick will be displayed in the upper line on the right.

The measured value remains on the display when the wall thickness probe is removed from the pipe.

Note!

For pipe materials whose longitudinal sound velocity can be used for the measurement of the volumetric flow rate see annex C, Table C.1.

18.3.3 Further Information on the Measurement

SIGNAL IS GOOD
3.51 mm

Press key  to obtain information on the measuring signal.

This message will be displayed if the measuring signal is sufficient. The LED of the channel will light green.

ERRORSIGNAL #
mm?

This message will be displayed if the measuring signal is not sufficient (# = number). The LED of the measuring channel will light red.

Q=■■■■■■■
3.51 mm

Press key  again. The bar graph of the signal quality (Q=) will be displayed.

If the signal is not sufficient for a measurement, UNDEF will be displayed. The LED of the measuring channel will light red. Shift the wall thickness probe slightly on the pipe until the LED of the measuring channel lights green.

Wall Thickness
LZ= 186 ns

Press key **3** END to display the transit time of the signal.

18.3.4 Errors during the Measurement

If no valid wall thickness can be measured,

- remove the wall thickness probe from the pipe wall
- clean the wall thickness probe and the position on the pipe where the measurement takes place
- apply a thin film of the coupling compound to the pipe wall
- press the wall thickness probe against the pipe wall in this position
- try measuring again

Note!	Use a small amount of coupling compound. Press the wall thickness probe evenly against the pipe wall.
--------------	---

18.3.5 Possible Reasons for Incorrect Measuring Results

- **temperature fluctuations:**
The sound velocity is temperature dependent.
- **doubling effect:**
When measuring the wall thickness using ultrasonic signals, a phenomenon called the doubling effect can occur if the wall thickness is smaller than the min. measuring range of the probe. The measured value is then twice (or sometimes three times) as high as the actual wall thickness because of repeated reflections of the ultrasonic signal.
- **the measured value is too low:**
The ultrasonic signal was reflected by a defect and not by the boundary layer, resulting in a shorter transit time and therefore a lower wall thickness.
- **warped surfaces:**
The probe has to be pressed centrally against the pipe or cylindrical vessel. The applied pressure must be constant. The acoustic partition boundary of the wall thickness probe must be perpendicular to the longitudinal axis of the pipe.
- **surface conditions:**
Regular unevenness (e.g. small grooves) on the surface of the pipe can result in wrong measured values. Normally, this problem can be avoided by turning the wall thickness probe ins such way that the acoustic partition boundary of the pipe is perpendicular to the orientation of the grooves (see Fig. 18.2).

When measuring on a rough surface, applying too much of the coupling compound can result in wrong measured values. A measurement on a very rough surface might be impossible (message NO COUPLING will be displayed). In this case, the surface has to be smoothed.

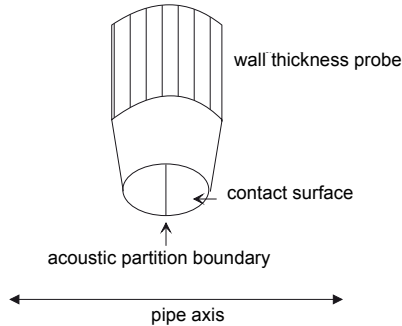

Fig. 18.2: Acoustic partition boundary

18.3.6 Store/Transmit the Wall Thickness

Press ENTER to stop the measurement and to store or output the measured value. The following display appears if a valid wall thickness has been measured and a measured value output is activated.

```

Transfer Data
no                >YES<
  
```

Select *yes* to store and/or output the measured value.

- The wall thickness can be transmitted into the current parameter record.
- The pipe material will be replaced by the material used for the wall thickness measurement.

If the serial output is activated, the measured value will be transmitted.

18.3.7 Stop of the Wall Thickness Measurement

To quit the wall thickness measurement mode, disconnect the wall thickness measurement from the transmitter.

19 Heat Flow and Heat Quantity

If the transmitter has the optional heat quantity measurement and two temperature inputs, the heat flow and the heat quantity can be measured.

19.1 Measuring Setup

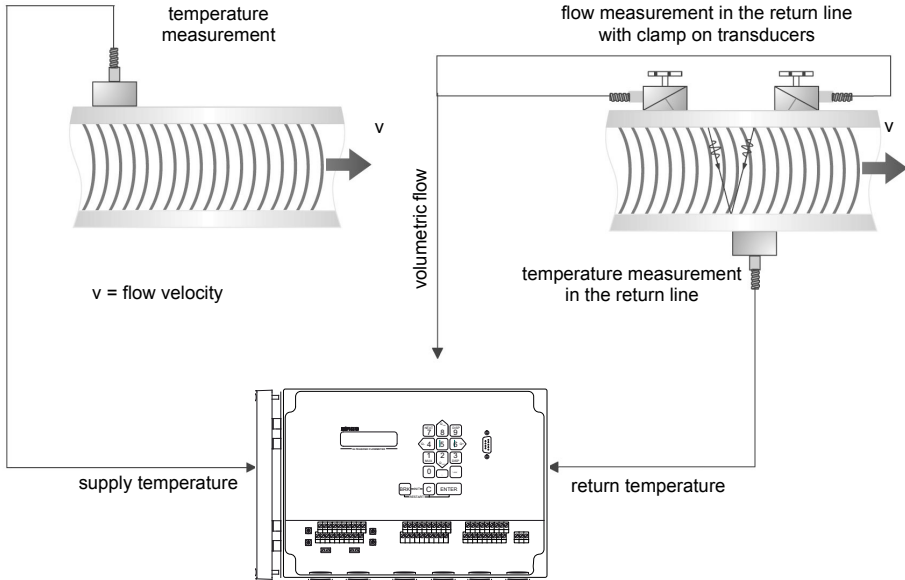

Fig. 19.1: Measurement of heat flow and heat quantity

One temperature probe is fixed on each the supply and the return line (see chapter 7). The transducers for the flow measurement are fixed on the return line (see section 9.6). The return temperature is the temperature at the measuring point.

19.2 Calculation of the Heat Flow and the Heat Quantity

The following physical quantities are used for the calculation:

- supply temperature
- return temperature (medium temperature)
- volumetric flow rate in the return line
- density, temperature and pressure of the medium

Note!

If the supply or return temperature is known and constant during the whole measurement, this temperature can be entered in the transmitter and the corresponding temperature probe does not need to be connected.

10 medium-dependent heat flow coefficients are needed for the heat flow measurement. The heat flow coefficients of some media are stored in the internal database of the transmitter. The heat flow coefficients of the other media must be entered before the start of the measurement.

A temperature correction value (offset) can be defined for each temperature input (see section 20.5).

If the supply pressure is constant or can be measured with an additional input, the heat flow and the heat quantity can be determined for a medium that is vaporous in the supply line (see section 19.5).

19.3 Settings

- Configure the temperature inputs in `Special Funct.\SYSTEM settings\Proc. inputs` (see section 20.1).
- If necessary, enter the heat flow coefficients of the medium (see section 14.3.4).
- Select program branch `Output Options`.

```
Output Options  ⬆
for Channel    A:
```

Select the measuring channel on which the heat flow is to be measured (the channel to which the temperature inputs have been assigned). Press ENTER.

This display will not be indicated if the transmitter has only one measuring channel.

```
Physic. Quant. ⬆
Heatflow
```

Select `Heatflow` as the physical quantity. Press ENTER.

- Select `Special Funct.\SYSTEM settings\Measuring`. Press ENTER until the list item `Heat Quantity` is displayed.

```
Heat Quantity
>[J]<      [Wh]
```

Select the unit of measurement (J or Wh). Press ENTER.

```
heat+flow quant.
off        >ON<
```

Select on to output both the volume totalizer and the heat quantity totalizer.

19.4 Measurement

Start the measurement as usual.

```
Heatflow
*INVALID MEDIUM*
```

If no heat flow coefficients are available for the selected medium, an error message will be displayed.

```
T1= 90.2   C
T2= 70.4   C
```

The two temperature inputs are checked and the measured temperatures are displayed. Press ENTER.

```
T1=?UNDEF  C
T2= 70.4   C
```

If a temperature can not be measured (the temperature probe is not connected or is defective), the error message ?UNDEF will be displayed.

```
A:T1 manualFIX
   0.0         C
```

If Fixed input val. has been selected during the configuration of the temperature input, the value has to be entered now.

Enter the medium temperature. Press ENTER.

Note!

A fixed temperature should be entered if e.g. the temperature can only be measured with difficulties on the supply line but the supply temperature is known and constant.

```
A:T1 manualFIX
   10.0        C
```

For simulations, it is possible to enter the supply and return temperatures as constants.

In this case, do not connect the temperature probes to the transmitter. The temperatures must be entered.

```
A:Heatflow
   0.0         kW
```

As soon as all necessary values are entered, the measured heat flow will be displayed.

If the heat quantity is also to be measured, the heat quantity totalizer will have to be activated (see section 11.2).

19.5 Steam in the Supply Line

If the supply pressure is constant or can be measured with an additional input, the heat flow and the heat quantity can be determined for a medium that is vaporous in the supply line.

The state of aggregation of the medium will be determined by means of the supply pressure and the supply temperature.

Note! The measurement of the volumetric flow rate, and thus of the heat flow, is only possible when the medium is liquid in the return line.

The steam coefficients of water and ammonia are stored in the internal database of the transmitter. The steam coefficients of the other media must be entered with the program FluxKoef.

19.5.1 Activating/Deactivating

SYSTEM settings ⬆
Dialogs/Menus

Select Special Funct.\SYSTEM settings\Dialogs/Menus\Steam in inlet.

Steam in inlet
off >ON<

Select on to activate Steam in inlet. The state of aggregation of the medium will be determined by means of the supply pressure and the supply temperature.

Select off to activate Steam in inlet. The medium is always assumed to be liquid in the supply line.

Inlet pressure
10.0 bar

If Steam in inlet is activated, the supply pressure must be entered in the program branch Parameter.

Enter the supply pressure. Press ENTER.

Note! The menu item Steam in inlet will always be displayed independently of the selected physical quantity. However, the supply pressure will only be used for the heat flow measurement.

19.5.2 Displays

During the heat flow measurement, the calculated state of aggregation can be displayed in the upper line by pressing key .

supply=LIQUID
426.23 kW

This message will be displayed if the medium in the supply line is completely liquid.

supply=STEAM
9565.23 kW

This message will be displayed if the medium in the supply line is completely vaporous.

```
supply=BOILING!  
7895.78 kW
```

This message will be displayed if the medium in the supply line is in the phase transition (critical range).

In this case, an exact measurement of the heat flow is not possible because the proportion of the medium in liquid phase in the supply line must be known in order to calculate the enthalpy of the supply.

The critical range of water is ± 3 °C around the boiling temperature. For this range, the heat flow is calculated with the steam saturation enthalpy.

```
HEATFLOW  
7895.78 kW
```

If the medium is in the critical range, the physical quantity will be displayed in capital letters.

20 Inputs

External transducers can be connected to the inputs (optional) to measure the following physical quantities:

- temperature
- density
- pressure
- kinematic viscosity
- dynamic viscosity

The values of the current, voltage, and temperature inputs can be used by all measuring channels.

An input must be assigned to a measuring channel (see section 20.1 and 20.3) and activated (see section 20.4) before it can be used for the measurement and for the storing of measured values.

Note! If a new input module has been installed, the transmitter must be re-started (RESET or off/on) in order for the new inputs to be identified.

SYSTEM settings ⇅
Proc. inputs

Select Special Funct.\SYSTEM settings\Proc. inputs.

Depending on the configuration of the transmitter, one or several of the following list items will be displayed:

Table 20.1: List items for Proc. inputs

list item	function
Link temperature	assigning of the temperature inputs to the measuring channels
Link other inp.	assigning of other inputs to the measuring channels
PT100/PT1000	selection of a temperature probe
...go back	return to the precedent menu item

20.1 Assigning the Temperature Inputs to the Measuring Channels

20.1.1 Temperature Inputs and the Heat Flow Measurement

For the heat flow measurement, the supply and return temperature must be assigned to the corresponding measuring channel as T-Inlet and T-Fluid/Outle (see section 20.1.2). These temperatures are usually measured, but can also be entered as constants.

With the configuration in Table 20.2, two independent heat flow measurements can be made simultaneously. The temperature measured by T2 can not be used for the heat flow measurement on measuring channel B, but can be displayed and output.

Note! The physical quantity `Heatflow` will only be displayed in the program branch `Output Options` of a measuring channel if a supply and return temperature have been assigned to this channel.

Table 20.2: Example of a configuration of the temperature inputs for the heat flow measurement

	temperature input
measuring channel A	
supply temperature	T1
return temperature	T2
heat quantity measurement	possible
measuring channel B	
supply temperature	constant value
return temperature	T4
heat quantity measurement	possible

20.1.2 Assignment of the Temperature Inputs

SYSTEM settings ⇅
Proc. inputs

Select `Special Funct.\SYSTEM settings\ Proc. inputs`. Press `ENTER`.

Proc. inputs ⇅
Link temperature

Select the list item `Link temperature`.

A:T-Inlet ⇅
Input T1

Select the temperature input to be assigned to measuring channel A as the supply temperature.

Select the list item `Fixed input val.` if the temperature is to be entered manually before the measurement.

Select the list item `No measuring` if no supply temperature is to be assigned to measuring channel A.

Press `ENTER`.

Select the list items for `T-Fluid/Outlet`, `T(3)` and `T(4)` of measuring channel A and the other activated channels accordingly. Press `ENTER` after each input.

Note! The configuration of a measuring channel will be stored when the next channel is selected. The configuration dialog of a channel must be finished to store the changes.

20.2 Selection of the Temperature Probe

SYSTEM settings ⇅
Proc. inputs

Select Special Funct.\SYSTEM settings\Proc. inputs. Press ENTER.

Proc. inputs ⇅
PT100 / PT1000

Select the list item PT100/PT1000.

Input T1 ⇅
>PT100< pt1000

Select the temperature probe.

If necessary, select the temperature probe for Input T2...T4 accordingly.

20.3 Assignment of Other Inputs to the Measuring Channels

SYSTEM settings ⇅
Proc. inputs

Select Special Funct.\SYSTEM settings\Proc. inputs. Press ENTER.

Proc. inputs ⇅
Link other inp.

Select the list item Link other inp..

A:ext.Input(1)
Input I1

Select the first input to be assigned to measuring channel A. Only the installed inputs are displayed in the scroll list.

Select the list item No measuring if no input is to be assigned to measuring channel A.

Press ENTER.

Select the list items for ext.Input(2)...(4) of measuring channel A and the other activated channels accordingly.

Note!

The configuration of a measuring channel will be stored when the next channel is selected. The configuration dialog of a channel has to be finished to store the changes.

20.4 Activation of the Inputs

The activation of the inputs in program branch `Output Options` will only be displayed if the transmitter has inputs of the corresponding type and they have been assigned to a measuring channel.

20.4.1 Activation of the Temperature Inputs

Note! If `Heatflow` has been selected as the physical quantity, the corresponding temperature inputs will be activated automatically. The steps described below are only necessary if the measured temperatures are to be displayed or output.

Temperature inputs must be activated if the measured temperatures are to be displayed, stored and/or output or if the measured temperature is to be used for the interpolation of the viscosity and the density of the medium.

Temperature	T1
no	>YES<

Select in the program branch `Output Options` the channel for which a temperature input has to be activated.

The temperature inputs assigned to the channel will be displayed one after another. Select `yes` for the temperature inputs that are to be activated.

Note! The total number of measured values that can be stored will be reduced if a temperature input is activated.

20.4.2 Activation of Other Inputs

Attention! Observe the correct polarity to avoid damaging the current source. A permanent short circuit can lead to the destruction of the current input.

Inputs must be activated if the measured values are to be displayed, stored and/or output together with the other measured values.

Input	I1
no	>YES<

In the program branch `Output Options`, select the channel for which an input is to be activated.

The inputs assigned to the channel will be displayed one after another. Select `yes` for the inputs that are to be activated.

Note! The total number of measured values that can be stored will be reduced if an input is activated.

20.5 Temperature Correction

A temperature correction value (offset) can be set for each temperature input. If a correction value has been defined, it will be added automatically to the measured temperature. This function is useful if e.g.:

- the characteristic curves of the two temperature probes differ considerably from each other.
- a known and constant temperature gradient exists between the measured temperature and the actual temperature.

20.5.1 Activating/Deactivating the Temperature Correction

The temperature correction can be activated/deactivated in program branch `Special Funct.\SYSTEM settings\Dialogs/Menus`.

```
Tx Corr.Offset
off                >ON<
```

Select `on` to activate the temperature correction, `off` to deactivate it.

Note!

If `off` is selected, the temperature correction will be deactivated for all inputs. However, the entered correction values for each temperature input will be stored and displayed again when the temperature correction is activated again.

20.5.2 Input of the Temperature Correction

During the flow transducer positioning, the correction values will be requested for each input which has been activated and where the temperature can be measured.

```
T1 Corr.Offset
0.3          C
```

Enter the offset for the temperature input.
Press ENTER.

Note!

Only measured temperatures can be corrected.

In order to adjust the zero point, the same reference temperature is measured with the two temperature probes. The difference between the two measured temperatures is entered as the offset for one of the temperature inputs. The difference can also be distributed between the offsets of the two channels.

The display of the temperature difference T1-T2 does not indicate if one or both temperatures are constant or if the values have been corrected.

```
T1= 90.5 C (COR)
0.0          kW
```

During the measurement, a corrected temperature value is marked by `cor`.

21 Outputs

If the transmitter is equipped with outputs, they have to be installed and activated before they can be used:

- assign a measuring channel (source channel) to the output (if the transmitter has more than one measuring channel)
- assign the physical quantity (source item) to be transmitted to the output by the source channel, and the properties of the signal
- define the behavior of the output in case no valid measured values are available
- activate of the installed output in the program branch `Output Options`

21.1 Installation of an Output

All outputs are installed in `Special Funct.\SYSTEM settings\Proc. outputs.`

Note! The configuration of an output will be stored at the end of the dialog. If the dialog is quit by pressing key BRK, the changes will not be stored.

SYSTEM settings ⬆
Proc. outputs

Select `Special Funct.\SYSTEM settings\Proc. outputs.` Press ENTER.

Install Output ⬆
Current I1

Select the output to be installed. Press ENTER.

The scroll list contains all available outputs. A tick ✓ after a list item indicates that this output has already been installed.

I1 enable
no >YES<

This display will be indicated if the output has not been installed yet. Select `yes`. Press ENTER.

I1 disable
>NO< yes

If the output has already been installed, select `no` to reconfigure it or `yes` to uninstall the output and to return to the previous menu item to select another output. Press ENTER.

I1 Source chan. ⬆
Channel A:

Select in the scroll list the measuring channel to be assigned to the output as the source channel. Press ENTER.

This display will not be indicated, if the transmitter has only one measuring channel or only one measuring channel is active.

I1 Source item \updownarrow Measuring value
--

Select the physical quantity (source item) to be transmitted from the source channel to the output.

If a binary output is configured, only the list items `Limit` and `Impuls` will be displayed.

The source items and their scroll lists are shown in Table 21.1.

Table 21.1: Configuration of the outputs

source item	list item	output
Measuring value	actual measure	physical quantity selected in the program branch Output Options
	Flow	flow, independently of the physical quantity selected in the program branch Output Options
	Heatflow	heat flow, independently of the physical quantity selected in the program branch Output Options
Quantity	Q+	totalizer for the positive flow direction
	* actual measure	totalizer for the physical quantity selected in the program branch Output Options
	* Flow	flow totalizer
	* Heatflow	totalizer for the heat flow
	Q-	totalizer for the negative flow direction
	* actual measure	totalizer for the physical quantity selected in the program branch Output Options
* Flow	flow totalizer	
* Heatflow	totalizer for the heat flow	
	ΣQ	sum of the totalizers (positive and negative flow direction)
	* actual measure	totalizer for the physical quantity selected in the program branch Output Options
	* Flow	flow totalizer
	* Heatflow	totalizer for the heat flow
Limit	R1	limit message (alarm output R1)
	R2	limit message (alarm output R2)
	R3	limit message (alarm output R3)
Temperature	T-Inlet (T1)	Is only available if a temperature input has been assigned to the channel. supply temperature for the heat flow measurement
	T-Outlet (T2)	return temperature for the heat flow measurement
	T(3)=EINGANG T3	further temperature input
	T(4)=INPUT T4	further temperature input
	TV(=T1)-TR(=T2)	difference between supply and return temperature
	TV(=T1)-T3	difference between supply temperature and T(3)
	TR(=T2)-T3	difference between return temperature and T(3)
	TV(=T1)-T4	difference between supply temperature and T(4)
	TR(=T2)-T4	difference between return temperature and T(4)
	T3-T4	difference between T(3) and T(4)

Table 21.1: Configuration of the outputs

source item	list item	output
Impuls	from abs(x)	pulse without sign consideration
	from x > 0	pulse for positive measured values
	from x < 0	pulse for negative measured values
Miscellaneous	c-Medium	sound velocity of the medium
	Signal	signal amplitude of a measuring channel

21.1.1 Output Range

I1 Output range ⬆
4/20 mA

When configuring an analog output, the output range will be defined now. Select a list item or other range... to enter the output range manually.

I1 Output MIN ⬆
10.0 mA

If other range... has been selected, enter the values Output MIN and Output MAX. Press ENTER after each input.

I1 Output MAX ⬆
11.0 mA

I1 Output MAX ⬆
12.0 MINIMAL

This error message will be displayed if the output range is not min. 10 % of the max. output range. The next possible value will be displayed. Repeat the input.

example: $I_{MAX} - I_{MIN} \geq 2 \text{ mA}$ for a 4...20 mA current output

21.1.2 Error Output

In the following dialog, an error value can be defined which is to be output if the source item can not be measured e.g. if there are gas bubbles in the medium.

Table 21.2: Error output

error value	result
Minimum	output of the lower limit of the output range
Hold last value	output of the last measured value
Maximum	output of the upper limit of the output range
Other value...	The value must be entered manually. It must be within the limits of the output.

example: source item: volumetric flow rate
 output: current output
 output range: 4...20 mA
 error value delay t_d (see section 21.2): > 0

The volumetric flow rate can not be measured during the time interval $t_0...t_1$ (see Fig. 21.1). The error value will be output.

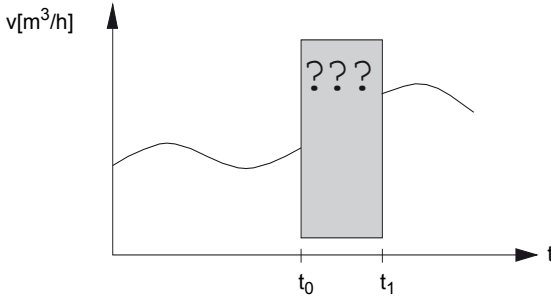
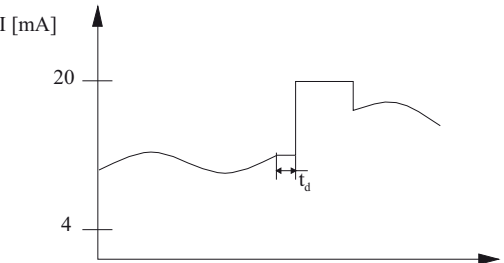
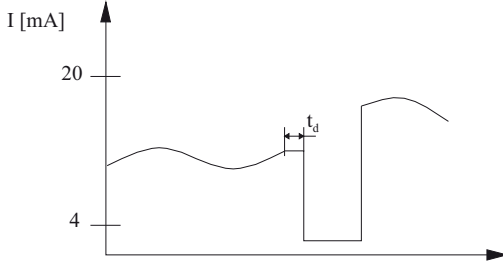

Fig. 21.1: Error output

Table 21.3: Examples for the error output

list item for the error output	output signal
<div style="border: 1px solid black; padding: 5px; margin-bottom: 5px;"> Error-value ⇅ Minimum (4.0mA) </div>	
<div style="border: 1px solid black; padding: 5px; margin-bottom: 5px;"> Error-value ⇅ Hold last value </div>	

Table 21.3: Examples for the error output

list item for the error output	output signal
<div style="border: 1px solid black; padding: 5px;"> Error-value ⇅ Maximum (20.0mA) </div>	
<div style="border: 1px solid black; padding: 5px;"> Error-value ⇅ Other value... </div> <p>error output = 2 mA</p>	

Error-value ⇅
 Minimum (4.0mA)

Select a list item for the error output. Press ENTER.

Error-value ⇅
 3.5 mA

If `Other value` has been selected, enter an error value. It has to be within the limits of the output. Press ENTER.

Note! The settings will be stored at the end of the dialog.

21.1.3 Function Test

The function of the installed output can now be tested. Connect a multimeter to the installed output.

Test of the Analog Outputs

I1:Output Test ⇅
 4 mA

The current output is tested in the display. Enter a test value. It has to be within the output range. Press ENTER.

```
I1= 4.0 mA
Again? no >YES<
```

If the multimeter displays the entered value, the output functions correctly.

Select **yes** to repeat the test, **no** to return to **SYSTEM** settings. Press **ENTER**.

Test of the Binary Outputs

```
B1:Output Test ↕
Reed-Relay OFF
```

Select **Reed-Relay OFF** or **Open collect OFF** in the scroll list **Output Test** to test the de-energized state of the output. Press **ENTER**. Measure the resistance at the output. The value has to be high ohmic.

Select **yes**. Press **ENTER**.

```
B1=OFF
AGAIN? no >YES<
```

```
B1:Output Test ↕
Reed-Relay ON
```

Select **Reed-Relay ON** or **Open collect**. **ON** in the scroll list **Output Test** to test the energized state of the output. Press **ENTER**. Measure the resistance at the output. The value has to be low ohmic.

Select **yes** to repeat the test, **no** to return to **SYSTEM** settings. Press **ENTER**.

```
B1=ON
AGAIN? no >YES<
```

21.2 Error Value Delay

The error value delay is the time interval after which the error value will be transmitted to the output in case no valid measured values are available. The error value delay can be entered in the program branch **Output Options** if this menu item has been previously activated in the program branch **Special Funct..** If the error value delay is not entered, the damping factor will be used.

```
Error-val. delay
>DAMPING< edit
```

Select **Special Funct.\SYSTEM settings\Dialogs/Menus/Error-val. delay**.

Select **Damping** if the damping factor is to be used as the error value delay. Select **Edit** to activate the menu item **Error-val. delay** in the program branch **Output Options**.

```
Error-val. delay
10 s
```

From now on, the error value delay can be entered in the program branch **Output Options**.

21.3 Activation of an Analog Output

Note! An output can only be activated in the program branch `Output Options` if it has been previously installed.

```
Output Options  ⬆
for Channel    A:
```

In the program branch `Output Options`, select the channel for which an output is to be activated. Press `ENTER`.

This display will not be indicated, if the transmitter has only one measuring channel.

```
Current Loop
I1: no        >YES<
```

Press `ENTER` until `Current Loop` is displayed. Select `yes` to activate the output. Press `ENTER`.

21.3.1 Measuring Range of the Analog Outputs

After an analog output has been activated in the program branch `Output Options`, the measuring range of the source item must be entered.

```
Meas.Values
>ABSOLUT<    sign
```

Select `sign` if the sign of the measured values is to be considered for the output.

Select `absolut` if the sign is not to be considered.

```
Zero-Scale Val.
0.00        m3/h
```

Enter the lowest expected measured value. The unit of measurement of the source item will be displayed.

`Zero-Scale Val.` is the measured value that corresponds to the lower limit of the output range as defined in section 21.1.1.

```
Full-Scale Val.
300.00     m3/h
```

Enter the highest expected measured value.

`Full-Scale Val.` is the measured value that corresponds to the upper limit of the output range as defined in section 21.1.1.

example: output: current output
 output range: 4...20 mA
 Zero-Scale Val.: 0 m³/h
 Full-Scale Val.: 300 m³/h
 volumetric flow rate = 0 m³/h, corresponds to 4 mA
 volumetric flow rate = 300 m³/h, corresponds to 20 mA

21.3.2 Function Test

The function of the installed output can now be tested. Connect a multimeter to the installed output.

```
I1: Test output ?
no          >YES<
```

Select *yes* to activate the output. Press ENTER.

```
I1: Test value =
5.00      m3/h
```

Enter a test value. The value must be indicated on the connected multimeter. Press ENTER.

```
I1: Test output ?
no          >YES<
```

Select *yes* to repeat the test. Press ENTER.

21.4 Configuration of a Frequency Output as a Pulse Output

A frequency output sends a signal with a frequency that depends on the volume flow rate. The frequency output can be configured in such way that the source item can be totalized by using each period of the output signal as the increment.

Installation of a frequency output (optional):

```
Install Output ↕
Frequency F1
```

Select *Frequency F1* in *Special Funct.\SYSTEM settings\Proc. outputs*. Press ENTER.

```
F1 enable
no          >YES<
```

Select *yes* if the output has not been installed. Press ENTER.

or

```
F1 disable
>NO<          yes
```

Select *no* if the output has already been installed. Press ENTER.

```
F1 Source chan. ↕
Channel A:
```

Select in the scroll list the measuring channel to be assigned to the output as the source channel. Press ENTER.

```
F1 Source item ↕
Measuring value
```

Select in the scroll list *Measuring value* (but not *Impuls!*). Press ENTER.

```
Setup as pulse ?
no          >YES<
```

If *Measuring value* has been selected and the source item can be totalized, a request will be indicated whether the frequency output is to be configured as a pulse output. Select *yes*. Press ENTER.

```
F1 Output MAX
1.0      kHz
```

Enter the upper limit of the frequency. Press ENTER.

The lower limit of the frequency and the error value will be set automatically to 0.5 Hz.

Activation of the output:

```
Output Options ⇕
for Channel  A:
```

In the program branch `Output Options`, select the channel for which the input is to be activated. Press `ENTER`.

This display will not be indicated if the transmitter has only one measuring channel.

Select `yes` to activate the output. Press `ENTER`.

```
Frequency Output
F1: no      >YES<
```

```
Pulses per unit:
1000      /m3
```

Enter the number of pulses that is to be assigned to the unit of measurement of the totalizer. Press `ENTER`.

Example: 1000 pulses correspond to 1 m³ of the totalized medium.

```
INFO: max flow=
3600.0      m3/h
```

The max. flow depending on the upper limit of the frequency and pulse value is indicated. Press `ENTER`.

21.5 Activation of a Binary Output as a Pulse Output

A pulse output is an integrating output which emits a pulse when the volume or the mass of the medium which has passed the measuring point reaches a given value (`Pulse Value`). The integrated quantity is the selected physical quantity. Integration is restarted as soon as a pulse is emitted.

Note!

The menu item `Pulse Output` will only be indicated in the program branch `Output Options` if a pulse output has been installed.

```
Output Options ⇕
for Channel  A:
```

Select in the program branch `Output Options` the channel for which a pulse output is to be activated. Press `ENTER`.

This display will not be indicated if the transmitter has only one measuring channel.

Select `yes` to activate the output. Press `ENTER`.

```
Pulse Output
B1: no      >YES<
```

```
Pulse Output
NO COUNTING !
```

This error message will be displayed if the flow velocity has been selected as the physical quantity.

The use of the pulse output is not possible in this case because integrating the flow velocity does not result in a reasonable value.

Pulse Value	0.01	m3
-------------	------	----

Enter the pulse value. The unit of measurement will be displayed according to the current physical quantity.

When the totalized physical quantity reaches the pulse value, a pulse will be emitted.

Pulse Width	100	ms
-------------	-----	----

Enter the pulse width.

The range of possible pulse widths depends on the specification of the instrument (e.g. counter, PLC) that is to be connected to the output.

The max. flow that the pulse output can work with will be displayed now. This value is calculated on the basis of the entered pulse value and pulse width.

If the flow exceeds this value, the pulse output will not function properly. In this case, the pulse value and the pulse width must be adapted to the flow conditions. Press ENTER.

21.6 Activation of a Binary Output as an Alarm Output

Note!	The menu item <code>Alarm Output</code> will only be displayed in the program branch <code>Output Options</code> if an alarm output has been installed.
--------------	---

Max. 3 alarm outputs R1, R2, R3 per channel operating independently of each other can be configured. The alarm outputs can be used to output information on the current measurement or to start and stop pumps, motors, etc.

21.6.1 Alarm Properties

The switching condition, the holding behavior and the switching function of an alarm output can be defined.

Table 21.4: Alarm properties

alarm property	setting	description
func (switching condition)	MAX	The alarm will switch if the measured value exceeds the upper limit.
	MIN	The alarm will switch if the measured value falls below the lower limit.
	+→- -→+	The alarm will switch if the flow direction changes (sign change of measured value).
	QUANT.	The alarm will switch if totalizing is activated and the totalizer reaches the limit.
	ERROR	The alarm will switch if a measurement is not possible.
	OFF	The alarm is switched off.

Table 21.4: Alarm properties

alarm property	setting	description
typ (holding behaviour)	NON-HOLD HOLD	If the switching condition is not true anymore, the alarm will return to the idle state after approx. 1 s. The alarm remains activated even if the switching condition is not true anymore.
mode (switching function)	NO Cont. NC Cont.	The alarm is energized if the switching condition is true and de-energized if idle. The alarm is de-energized if the switching condition is true and energized if idle.

Note! If no measurement is made, all alarms will be de-energized, independently of the programmed switching function.

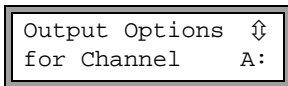

Select in the program branch **Output Options** the channel for which an alarm output is to be activated. Press **ENTER**.

This display will not be indicated if the transmitter has only one measuring channel.

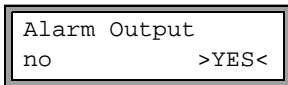

Select **yes** to activate the alarm output. Press **ENTER**.

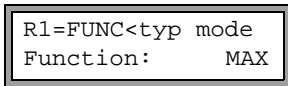

Three scroll lists will be displayed:

- func: switching condition
- typ: holding behaviour
- mode: switching function

Press key **4** and **6** to select a scroll list in the upper line. Press key **8** and **2** to select a list item in the lower line.

Press **ENTER** to store the settings.

21.6.2 Setting the Limits

If the switching condition **MAX** or **MIN** has been selected in the scroll list **func**, the limit of the output will have to be defined:

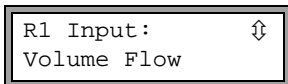

Select in the scroll list **Input** the physical quantity to be used for the comparison. The following list items are available:

- selected physical quantity
- signal amplitude
- sound velocity of the medium

Press **ENTER**.

High Limit:		
-10.00		m ³ /h

switching condition: MAX

Enter the upper limit. Press ENTER.

The alarm will switch if the measured value exceeds the limit.

Low Limit:		
-10.00		m ³ /h

switching condition: MIN

Enter the lower limit. Press ENTER.

The alarm will switch if the measured value falls below the limit.

example 1: High Limit:: -10 m³/hvolumetric flow rate = -9.9 m³/h

the limit is exceeded, the alarm switches

volumetric flow rate = -11 m³/h

the limit is not exceeded, the alarm does not switch

example 2: Low Limit:: -10 m³/hvolumetric flow rate = -11 m³/h

the measured value is below the limit, the alarm switches

volumetric flow rate = -9.9 m³/h

the measured value is not below the limit, the alarm does not switch

If the switching condition `QUANT` . has been selected in the scroll list `func`, the limit of the output will have to be defined:

Quantity Limit:		
1.00		m ³

switching condition: QUANT .

Enter the limit of the totalizer. Press ENTER.

The alarm will switch if the measured value reaches the limit.

A positive limit will be compared to the totalizer value for the positive flow direction.

A negative limit will be compared to the totalizer value for the negative flow direction.

The comparison will also take place if the totalizer of the other flow direction is displayed.

Note!

The unit of measurement of the limit corresponds to the unit of measurement of the selected physical quantity.

If the unit of measurement of the physical quantity is changed, the limit has to be converted and entered again.

example 1: physical quantity: volumetric flow rate in m³/h
Quantity Limit:: 1 m³

example 2: physical quantity. volumetric flow rate in m³/h
Low Limit:: 60 m³/h

The unit of measurement of the physical quantity is changed to m³/min.
The new limit to be entered is 1 m³/min.

21.6.3 Defining the Hysteresis

A hysteresis can be defined for the alarm output R1 to prevent a constant triggering of the alarm due to small fluctuations of the measured values around the limit.

The hysteresis is a symmetrical range around the limit. The alarm will be activated if the measured values exceed the upper limit and deactivated if the measured values fall below the lower limit.

example: High Limit:: 30 m³/h
Hysteresis: 1 m³/h

The alarm will be triggered at values > 30.5 m³/h and deactivated at values < 29.5 m³/h.

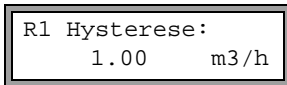

switching condition: MIN or MAX

Enter the value for Hysteresis.

or

Enter 0 (zero) to work without a hysteresis.

Press ENTER.

21.7 Behavior of the Alarm Outputs

21.7.1 Apparent Switching Delay

Measured values and totalizer values will be displayed rounded to two decimal places. The limits, however, will be compared to the non-rounded measured values. This might cause an apparent switching delay when the measured value changes marginally (less than two decimal places). In this case, the switching accuracy of the output is greater than the accuracy of the display.

21.7.2 Reset and Initialization of the Alarms

After a cold start, all alarm outputs will be initialized as follows:

Table 21.5: Alarm state after a cold start

func	OFF
typ	NON-HOLD
mode	NO Cont.
Limit	0.00

Press key C three times during the measurement to set all alarm outputs to the idle state. Alarm outputs whose switching condition is still met will be activated again after 1 s. This function is used to reset alarm outputs of the type `HOLD` if the switching condition is not met anymore.

By pressing key BRK, the measurement will be stopped and the main menu selected. All alarm outputs will be de-energized, independently of the programmed idle state.

21.7.3 Alarm Outputs during Transducer Positioning

At the beginning of the transducer positioning (bar graph display), all alarm outputs switch back to the programmed idle state.

If the bar graph is selected during measurement, all alarm outputs will switch back to the programmed idle state.

An alarm output of the type `HOLD` that has been activated during the previous measurement will remain in the idle state after the transducer positioning if the switching condition is not met anymore.

Switching of the alarms into the idle state will not be displayed.

21.7.4 Alarm Outputs during Measurement

An alarm output with switching condition `MAX` or `MIN` will be updated max. once per second to avoid humming (i.e. fluctuation of the measured values around the value of the switching condition).

An alarm output of the type `NON-HOLD` will be activated if the switching condition is met. It will be deactivated if the switching condition is not met anymore. The alarm will remain activated min. 1 s even if the switching condition is met for a shorter period of time.

Alarm outputs with the switching condition `QUANT.` will be activated if the limit is reached.

Alarm outputs with the switching condition `ERROR` will only be activated after several unsuccessful measuring attempts. Therefore, typical short-term disturbances of the measurement (e.g. switching on of a pump) will not activate the alarm.

Alarm outputs with the switching condition `+→- -→+` and of the type `NON-HOLD` will be activated with each change of the flow direction for approx. 1 s (see Fig. 21.2).

Alarm outputs with the switching condition $+\rightarrow- -\rightarrow+$ and of the type `HOLD` will be active after the first change of the flow direction. They can be switched back by pressing key C three times (see Fig. 21.2).

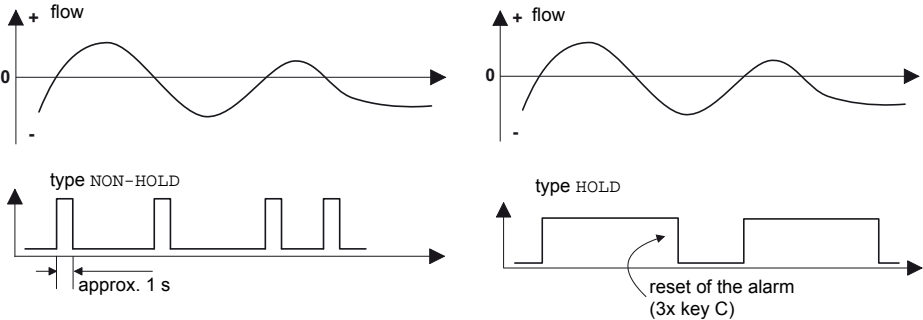

Fig. 21.2: Behavior of a relay when the flow direction changes

If there is an internal adaptation to changing measuring conditions, e.g. to a considerable rise of the medium temperature, the alarm will not switch. Alarm outputs with the switching condition `OFF` will be set automatically to the switching function `NO Cont..`

21.7.5 Alarm State Indication

Note! There is no visual or acoustic indication of alarm output switching.

The alarm state can be displayed during the measurement. This function is activated in `Special Funct.\SYSTEM settings\Dialogs/Menus`.

```
SHOW RELAIS STAT
off                >ON<
```













Select the menu item `SHOW RELAIS STAT`. Select `on` to activate the alarm state indication.

Scroll during the measurement with key 9 until the alarm state is displayed in the upper line.

$RX = \square \square \square \square$, with \square being a pictogram as shown in Table 21.6.

example: $R1 = \begin{matrix} \blacksquare & \blacksquare & \blacksquare & \blacksquare \\ \blacksquare & \blacksquare & \blacksquare & \blacksquare \\ \blacksquare & \blacksquare & \blacksquare & \blacksquare \\ \blacksquare & \blacksquare & \blacksquare & \blacksquare \end{matrix}$

Table 21.6: Pictograms for the alarm state indication

no.	func (switching condition)	typ (holding behavior)	mode (switching function)	current state
R	=			
1	 OFF	 NON-HOLD	 NO Cont.	 closed
2	 MAX	 HOLD	 NC Cont.	 open
3	 MIN			
	 + → - - → +			
	 QUANT.			
	 ERROR			

21.8 Deactivating the Outputs

If the programmed outputs are no longer required, they can be deactivated. The configuration of a deactivated output is stored and will be available if the output is activated again.

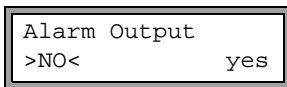

Select no in Output Options\Alarm Output to deactivate an output. Press ENTER.

22 Troubleshooting

If any problem appears which can not be solved with the help of this manual, contact our sales office and give a precise description of the problem. Specify the type, the serial number and the firmware version of the transmitter.

Calibration

FLUXUS is a very reliable instrument. It is manufactured under strict quality control, using modern production techniques. If installed as recommended in an appropriate location, used cautiously and taken care of conscientiously, no troubles should appear. The transmitter has been calibrated at the factory and, usually, a re-calibration of the transmitter will not be necessary. A re-calibration is recommended if

- the contact surface of the transducers shows visible wear or
- the transducers were used for a prolonged period of time at a high temperature (several months >130 °C for normal transducers or > 200 °C for high temperature transducers).

The transmitter has to be sent to FLEXIM for recalibration under reference conditions.

The display does not work at all or fails regularly

Check if the battery is inserted and charged. Connect the power supply. If the power supply is ok, the transducers or an internal component of the transmitter are defective. The transducers and the transmitter have to be sent to FLEXIM for repair.

The message **SYSTEM ERROR** is displayed

Press key BRK to return to the main menu.

If this message is displayed repeatedly, write down the number in the lower line. Track down the situations when the error is displayed. Contact FLEXIM.

The backlight of the display does not work, but all other functions are available.

The backlight is defective. This problem does not affect the other functions of the display. Send the transmitter to FLEXIM for repair.

Date and time are wrong, the measured values are deleted when the transmitter is switched off

The data backup battery has to be replaced. Send the transmitter to FLEXIM.

An output does not work

Make sure that the outputs are configured correctly. Check the function of the output as described in section 21.1.3. If the output is defective, contact FLEXIM.

A measurement is impossible or the measured values substantially differ from the expected values

see section 22.1.

The values of the totalizer are wrong

see section 22.6.

22.1 Problems with the Measurement

A measurement is impossible because no signal is received. A question mark is displayed in the lower line on the right

- Check if the entered parameters are correct, especially the outer pipe diameter, the pipe wall thickness and the sound velocity of the medium. (Typical errors: The circumference or the radius was entered instead of the diameter. The inner pipe diameter was entered instead of the outer pipe diameter.)
- Make sure that the recommended transducer distance was adjusted when mounting the transducers.
- Make sure that an appropriate measuring point has been selected (see section 22.2).
- Try to establish better acoustic contact between the pipe and the transducers (see section 22.3).
- Enter a lower value for the number of sound paths. The signal attenuation might be too high due to a high medium viscosity or deposits on the inner pipe wall (see section 22.4).

The measuring signal is received but no measured values can be obtained

- An exclamation mark "!" in the lower line on the right indicates that the defined upper limit of the flow velocity is exceeded and, therefore, the measured values are marked as invalid. The limit must be adapted to the measuring conditions or the check must be deactivated (see section 11.3).
- If no exclamation mark "!" is displayed, a measurement at the selected measuring point is not possible.

Loss of signal during the measurement

- If the pipe had run empty: Was there no measuring signal afterwards? Contact FLEX-IM.
- Wait briefly until acoustic contact is reestablished. The measurement can be interrupted by a temporarily higher proportion of gas bubbles and solids in the medium.

The measured values substantially differ from the expected values

- Wrong measured values are often caused by wrong parameters. Make sure that the entered parameters are correct for the measuring point.
- If the parameters are correct, see section 22.5 for the description of typical situations in which wrong measured values are obtained.

22.2 Selection of the Measuring Point

- Make sure that the recommended min. distance to any disturbance source is observed (see chapter 4, Table 4.2).
- Avoid measuring points with deposit formation in the pipe.
- Avoid measuring points in the vicinity of deformations and defects on the pipe and in the vicinity of welds.
- Measure the temperature at the measuring point and make sure that the transducers are suitable for this temperature.
- Make sure that the outer pipe diameter is within the measuring range of the transducers.
- When measuring on a horizontal pipe, the transducers must be mounted on the side of the pipes.
- A vertical pipe must always be filled at the measuring point and the medium should flow upward.
- No gas bubbles should form (even bubble-free media can form gas bubbles when the medium expands, e.g. upstream of pumps and downstream of great cross-section enlargements).

Note!

If the temperature fluctuates at the measuring point, it is especially important that the inner hooks of the clasp engage in the tension strip. Otherwise, the contact pressure of the transducers will be insufficient at low temperatures.

Note!

If the temperature fluctuates widely, it is recommended to use FLEX-IM clasps with springs to fix the transducers. Contact FLEXIM.

22.3 Maximum Acoustic Contact

Observe the instructions in chapter 6.

22.4 Application Specific Problems

The entered sound velocity of the medium is wrong

The entered sound velocity is used to calculate the transducer distance and is therefore very important for the transducer positioning. The sound velocities stored in the transmitter only serve as orientation.

The entered pipe roughness is not appropriate

Check the entered value. The state of the pipe should be taken into account.

Measurements on porous pipe materials (e.g. concrete or cast iron) are only possible under certain conditions

Contact FLEXIM.

The pipe liner may cause problems during the measurement if it is not firmly attached to the inner pipe wall or consists of an acoustically absorbing material

Try measuring on a liner free section of the pipe.

Highly viscous media strongly attenuate the ultrasonic signal

Measurements on media with a viscosity $> 1000 \text{ mm}^2/\text{s}$ are only possible under certain conditions.

A higher proportion of gas bubbles or solids in the medium scatter and absorb the ultrasonic signal and therefore attenuate the measuring signal

A measurement is impossible if the value is $\geq 10 \%$. If the proportion is high, but $< 10 \%$, a measurement is only possible under certain conditions.

The flow is in the transition range between laminar and turbulent flow where flow measurement is difficult

Calculate the Reynolds number of the flow at the measuring point with the program Flux-Flow (free download: www.flexim.com). Contact FLEXIM.

22.5 Large Deviations of the Measured Values

The entered sound velocity of the medium is wrong

A wrong sound velocity can result in the ultrasonic signal that is reflected directly on the pipe wall being mistaken for the measuring signal that has passed through the medium. The flow calculated on the basis of the wrong signal by the transmitter is very small or fluctuates around zero.

There is gas in the pipe

If there is gas in the pipe, the measured flow will always be too high because both the gas volume and the liquid volume are measured.

The defined upper limit of the flow velocity is too low

All measured flow velocities that are greater than the upper limit will be ignored and marked as invalid. All quantities derived from the flow velocity will also be marked as invalid. If several correct measured values are ignored, the totalizer values will be too low.

The entered cut-off flow is too high

All flow velocities below the cut-off flow are set to zero. All derived quantities are also set to zero. The cut-off flow (default: 2.5 cm/s) has to be set to a low value in order to be able to measure at low flow velocities.

The entered pipe roughness is not appropriate**The flow velocity to be measured is outside the measuring range of the transmitter****The measuring point is not appropriate**

Select another measuring point to check whether the results are better. Because pipes are never rotationally symmetric, the flow profile is affected. Change the transducer position according to the pipe deformation.

22.6 Problems with the Totalizers

The values of the totalizer are too high

See `Special Function\SYSTEM settings\Measuring\Quantity recall`. If this menu item is activated, the values of the totalizer will be stored. The totalizer will continue with this value at the start of the next measurement.

The values of the totalizer are too low

One of the totalizers has reached the upper limit and has to be reset to zero manually.

The sum of the totalizers is not correct

See `Special Function\SYSTEM settings\Measuring\Quant. wrapping`. The sum of both totalizers (throughput) transmitted via an output is not valid after the overflow (wrapping) of one of the totalizers.

A Menu Structure

	cold start resistant
Program Branch Parameter	
<div style="border: 1px solid black; padding: 5px; width: fit-content;"> >PAR< mea opt sf Parameter </div>	main menu: selection of the program branch Parameter
<div style="border: 1px solid black; padding: 5px; width: fit-content;"> Parameter ↕ for Channel A: </div>	selection of a measuring channel (A, B) or of a calculation channel (Y, Z) This display will not be indicated if the transmitter has only one measuring channel.
<div style="border: 1px solid black; padding: 5px; width: fit-content;"> Parameter from: ↕ Par.Record 01 </div>	selection of a parameter record This display will only be indicated if at least one parameter record has been defined.
<div style="border: 1px solid black; padding: 5px; width: fit-content;"> Edit Parameters >NO< yes </div>	selection if the the parameters of the parameter record are to be edited
when a measuring channel is selected (A, B)	
<div style="border: 1px solid black; padding: 5px; width: fit-content;"> Outer Diameter 100.0 mm </div>	input of the outer pipe diameter
<div style="border: 1px solid black; padding: 5px; width: fit-content;"> Pipe Circumfer. 314.2 mm </div>	input of the pipe circumference This display will only be indicated if Special Funct.\SYSTEM settings\Dialogs/ Menus\Pipe Circumfer. is activated and Outer Diameter = 0 has been entered.
<div style="border: 1px solid black; padding: 5px; width: fit-content;"> Wall Thickness 3.0 mm </div>	input of the pipe wall thickness range: depends on the connected transducers default: 3 mm
<div style="border: 1px solid black; padding: 5px; width: fit-content;"> Pipe Material ↕ Carbon Steel </div>	selection of the pipe material

		cold start resistant
<div style="border: 1px solid black; padding: 5px;"> c-Material 3230.0 m/s </div>	input of the sound velocity of the pipe material range: 600...6553.5 m/s This display will only be indicated if Other Material has been selected.	
<div style="border: 1px solid black; padding: 5px;"> Lining no >YES< </div>	selection whether the pipe is lined	
<div style="border: 1px solid black; padding: 5px;"> Lining ⬆ Bitumen </div>	selection of the lining material This display will only be indicated if Lining = yes has been selected.	
<div style="border: 1px solid black; padding: 5px;"> c-Material 3200.0 m/s </div>	input of the sound velocity of the lining material range: 600...6553.5 m/s This display will only be indicated if Other Material has been selected.	
<div style="border: 1px solid black; padding: 5px;"> Liner Thickness 3.0 mm </div>	input of the liner thickness default: 3 mm	
<div style="border: 1px solid black; padding: 5px;"> Roughness 0.4 mm </div>	input of the roughness of the inner pipe wall range: 0...5 mm default: 0.1 mm (for steel as pipe material)	
<div style="border: 1px solid black; padding: 5px;"> Medium ⬆ Water </div>	selection of the medium	
<div style="border: 1px solid black; padding: 5px;"> c-Medium MIN 1400.0 m/s </div>	input of the min. sound velocity of the medium range: 500...3500 m/s This display will only be indicated if Other Medium has been selected.	

	cold start resistant
<div style="border: 1px solid black; padding: 5px; margin-bottom: 10px;"> c-Medium MAX 1550.0 m/s </div> <p>input of the max. sound velocity of the medium This display will only be indicated if Other Medium has been selected.</p> <div style="border: 1px solid black; padding: 5px; margin-bottom: 10px;"> Kinem. Viscosity 1.00 mm²/s </div> <p>input of the kinematic viscosity of the medium range: 0.01...30 000 mm²/s This display will only be indicated if Other Medium has been selected.</p> <div style="border: 1px solid black; padding: 5px; margin-bottom: 10px;"> Density 1.00 g/cm³ </div> <p>input of the operating density of the medium range: 0.01...20 g/cm³ This display will only be indicated if Other Medium has been selected.</p> <div style="border: 1px solid black; padding: 5px; margin-bottom: 10px;"> Medium Temperat. 20.0 C </div> <p>input of the medium temperature default: 20 °C</p> <div style="border: 1px solid black; padding: 5px; margin-bottom: 10px;"> Fluid pressure 1.00 bar </div> <p>input of the medium pressure range: 1...600 bar This display will only be indicated if Special Funct.\SYSTEM settings\Dialogs/ Menus\Fluid pressure is activated.</p> <div style="border: 1px solid black; padding: 5px;"> Transducer Type ⬆ Standard </div> <p>selection of the transducer type This display will only be indicated if no or special transducers are connected.</p>	
<p>When a calculation channel is selected (Y, Z) Calculation channels will only be available if the transmitter has more than one measuring channel.</p>	
<div style="border: 1px solid black; padding: 5px; margin-bottom: 10px;"> Calculation: Y= A - B </div> <p>display of the current calculation function</p> <div style="border: 1px solid black; padding: 5px;"> >CH1< funct ch2 ⬆ A - B </div> <p>selection of the calculation function</p>	

	cold start resistant
Program Branch Measuring	
<pre>par >MEA< opt sf Measuring</pre>	main menu: selection of the program branch Measuring
<pre>CHANN: >A< B Y Z MEASUR ✓ ✓ - .</pre>	<p>activation of the channels</p> <p>This display will not be indicated if the transmitter has only one measuring channel.</p>
<pre>Time-progr.Meas. >NO< yes</pre>	<p>selection whether the measurement is to be started at a later time</p> <p>This display will only be indicated if</p> <ul style="list-style-type: none"> • Special Funct.\SYSTEM settings\ Dialogs/Menus\Time-progr.Meas. is activated and • Output Options\Store Meas.Data and/or Serial Output are activated.
<pre>A:Meas.Point No.: xxx (↑↓←→)</pre>	<p>input of the measuring point number</p> <p>This display will only be indicated if Output Options\Store Meas.Data and/or Serial Output are activated.</p>
<pre>A:PROFILE CORR. >NO< yes</pre>	<p>activating/deactivating the flow profile correction</p> <p>This display will only be indicated if Special Funct.\SYSTEM settings\Measuring\ Flow Velocity = uncorr. has been selected.</p>
<pre>A: Sound Path 2 NUM</pre>	<p>input of the number of sound paths</p> <p>This display will only be indicated if Special Funct.\SYSTEM settings\Dialogs/ Menus\Sound Path = USER has been selected.</p>
<pre>Transd. Distance A:54 mm Reflex</pre>	<p>display of the transducer distance to be adjusted between the inner edges of the transducers</p> <p>This display will only be indicated if in Special Funct.\SYSTEM settings\Dialogs/ Menus\Sound Path = user has been selected.</p>

	cold start resistant
<div style="border: 1px solid black; padding: 5px; width: fit-content;"> <p>S=■■■■■■■ A: ■<>■=54 mm!</p> </div>	bar graph S=, display of the amplitude of the received signal
Program Branch Output Options	
<div style="border: 1px solid black; padding: 5px; width: fit-content;"> <p>par mea >OPT< sf Output Options</p> </div>	main menu: selection of the program branch Output Options
<div style="border: 1px solid black; padding: 5px; width: fit-content;"> <p>Output Options ⇕ for Channel A:</p> </div>	selection of the channel whose output options are to be defined
<div style="border: 1px solid black; padding: 5px; width: fit-content;"> <p>Physic. Quant. ⇕ Volume Flow</p> </div>	selection of the physical quantity
<div style="border: 1px solid black; padding: 5px; width: fit-content;"> <p>Volume in: ⇕ m3/h</p> </div>	selection of the unit of measurement for the physical quantity
<div style="border: 1px solid black; padding: 5px; width: fit-content;"> <p>Temperature T1 no >YES<</p> </div>	activation of a temperature input This display will only be indicated if the temperature input T1 has been assigned to the channel in Special Funct.\SYSTEM settings\ Proc. inputs\Link temperature.
<div style="border: 1px solid black; padding: 5px; width: fit-content;"> <p>INPUT I1 no >YES<</p> </div>	activation of a current input for an external temperature measurement This display will only be indicated if the input I1 has been assigned to the channel in Special Funct.\SYSTEM settings\ Proc. inputs\Link other inp..
<div style="border: 1px solid black; padding: 5px; width: fit-content;"> <p>Damping 10 s</p> </div>	input of the duration over which a floating average of the measured values has to be determined range: 1...100 s
<div style="border: 1px solid black; padding: 5px; width: fit-content;"> <p>Store Meas.Data no >YES<</p> </div>	activation of the data logger

<div data-bbox="81 177 367 256" style="border: 1px solid black; padding: 5px;"> <p>Serial Output no >YES<</p> </div> <div data-bbox="81 288 367 368" style="border: 1px solid black; padding: 5px;"> <p>Storage Rate ⬆ Once per 10 sec.</p> </div> <div data-bbox="81 464 367 544" style="border: 1px solid black; padding: 5px;"> <p>Storage Rate 1 s</p> </div>	<p style="text-align: right;">cold start resistant</p> <p>activation of the measured value output to a PC or a printer via the serial interface</p> <p>selection of the storage rate for storing measured values in the data logger This display will only be indicated if Output Options\Store Meas.Data and/or Serial Output are activated.</p> <p>Input of the storage rate if Storage Rate = EXTRA has been selected range: 1...43 200 s (= 12 h)</p>
<p>Current Loop</p>	
<div data-bbox="81 643 367 722" style="border: 1px solid black; padding: 5px;"> <p>Current Loop I1: no >YES<</p> </div> <div data-bbox="81 818 367 898" style="border: 1px solid black; padding: 5px;"> <p>Meas.Values >ABSOLUT< sign</p> </div> <div data-bbox="81 962 367 1042" style="border: 1px solid black; padding: 5px;"> <p>Zero-Scale Val. 0.00 m3/h</p> </div> <div data-bbox="81 1082 367 1161" style="border: 1px solid black; padding: 5px;"> <p>Full-Scale Val. 300.00 m3/h</p> </div>	<p>activation of a current output This display will only be indicated if the current output has been installed in Special Funct.\SYSTEM settings\Proc. outputs.</p> <p>selection whether the sign of the measured values is to be considered for the output This display will only be indicated if Current Loop is activated.</p> <p>input of the lowest/highest measured value to be expected for the current output The values are assigned to the lower/upper limit of the output range.</p> <p>These displays will only be indicated if Current Loop is activated.</p>



	cold start resistant
<div style="border: 1px solid black; padding: 5px; margin-bottom: 10px;"> Error-val. delay 10 s </div> <p>input of the error value delay, i.e. of the time interval after which the value entered for the error output will be transmitted to the output if no valid measured values are available</p> <p>This display will only be indicated if <code>Special Funct.\SYSTEM settings\Dialogs/ Menus\Error-val. delay = EDIT</code> has been selected.</p>	
<p>Pulse Output</p>	
<div style="border: 1px solid black; padding: 5px; margin-bottom: 10px;"> Pulse Output B1: no >YES< </div> <p>Activation of a Pulse Output</p> <p>This display will only be indicated if a pulse output has been installed in <code>Special Funct.\SYSTEM settings\Dialogs/ Menus\Proc. outputs</code>.</p>	
<div style="border: 1px solid black; padding: 5px; margin-bottom: 10px;"> Pulse Value 0.01 m3 </div> <p>input of the pulse value (value of the totalizer at which a pulse will be emitted)</p> <p>This display will only be indicated if <code>Pulse Output</code> is activated.</p>	
<div style="border: 1px solid black; padding: 5px; margin-bottom: 10px;"> Pulse Width 100 ms </div> <p>input of the pulse width</p> <p>range: 1...1000 ms</p> <p>This display will only be indicated if <code>Pulse Output</code> is activated.</p>	
<p>Alarm Output</p>	
<div style="border: 1px solid black; padding: 5px; margin-bottom: 10px;"> Alarm Output no >YES< </div> <p>activation of an alarm output</p> <p>This display will only be indicated if an alarm output has been installed in <code>Special Funct.\SYSTEM settings\Proc. outputs</code>.</p>	
<div style="border: 1px solid black; padding: 5px; margin-bottom: 10px;"> R1=FUNC<typ mode Function: MAX </div> <p>Selection of the switching condition (<code>func</code>), the holding behavior (<code>typ</code>) and the switching function (<code>mode</code>) of the alarm output.</p> <p>This display will only be indicated if <code>Alarm Output</code> is activated.</p>	

	cold start resistant
<div style="border: 1px solid black; padding: 5px; width: fit-content;"> R1 Input: ↕ Volume Flow </div>	selection of the physical quantity to be monitored This display will only be indicated for R1 if Alarm Output is activated.
<div style="border: 1px solid black; padding: 5px; width: fit-content;"> High Limit: -10.00 m3/h </div>	input of the upper limit of the physical quantity to be monitored This display will only be indicated if Alarm Output has been activated and MAX has been selected as the switching condition.
<div style="border: 1px solid black; padding: 5px; width: fit-content;"> Low Limit: -10.00 m3/h </div>	input of the lower limit of the physical quantity to be monitored This display will only be indicated if Alarm Output has been activated and MIN has been selected as the switching condition.
<div style="border: 1px solid black; padding: 5px; width: fit-content;"> Quantity Limit: 1.00 m3 </div>	input of the limit for the totalizer of the physical quantity to be monitored This display will only be indicated if Alarm Output has been activated and QUANT. has been selected as the switching condition.
<div style="border: 1px solid black; padding: 5px; width: fit-content;"> R1 Hysterese: 1.00 m3/h </div>	input of the hysteresis for the lower or upper limit This display will only be indicated if Alarm Output has been activated and MIN or MAX has been selected as the switching condition.
<p>Program Branch Special Funct.</p>	
<div style="border: 1px solid black; padding: 5px; width: fit-content;"> par mea opt >SF< Special Funct. </div>	main menu: selection of the program branch Special Funct.
<p>SYSTEM settings</p>	
<div style="border: 1px solid black; padding: 5px; width: fit-content;"> Special Funct. ↕ SYSTEM settings </div>	selection of Special Funct.\SYSTEM settings

	cold start resistant
<p>SYSTEM settings\Set Clock</p>	
<div style="border: 1px solid black; padding: 5px; width: fit-content;"> SYSTEM settings ⇅ Set Clock </div>	<p>selection of the displays for the input of the date and the time</p>
<p>SYSTEM settings\Libraries</p>	
<div style="border: 1px solid black; padding: 5px; width: fit-content;"> SYSTEM settings ⇅ Libraries </div>	<p>selection of the displays for the management of the material and medium scroll lists</p>
<p>SYSTEM settings\Libraries\Material list</p>	
<div style="border: 1px solid black; padding: 5px; width: fit-content;"> Libraries ⇅ Material list </div>	<p>selection of the displays for the arrangement of the material scroll list (pipe and lining materials)</p>
<p>SYSTEM settings\Libraries\Medium list</p>	
<div style="border: 1px solid black; padding: 5px; width: fit-content;"> Libraries ⇅ Medium list </div>	<p>selection of the displays for the arrangement of the medium scroll list</p>
<p>SYSTEM settings\Libraries\Format USER-AREA</p>	
<div style="border: 1px solid black; padding: 5px; width: fit-content;"> Libraries ⇅ Format USER-AREA </div>	<p>selection of the displays for the partitioning of the coefficient memory for the storing of user defined material and medium properties</p>
<div style="border: 1px solid black; padding: 5px; width: fit-content;"> Format USER-AREA Materials: 03 </div>	<p>input of the number of user defined materials</p>
<div style="border: 1px solid black; padding: 5px; width: fit-content;"> Format USER-AREA Media: 03 </div>	<p>input of the number of user defined media</p>
<div style="border: 1px solid black; padding: 5px; width: fit-content;"> Format USER-AREA Heat-Coeffs: 00 </div>	<p>input of the number of user defined data sets for the heat flow coefficients</p>

	cold start resistant
<div style="border: 1px solid black; padding: 5px; width: fit-content;"> Format USER-AREA Steam-Coeffs: 00 </div>	input of the number of user defined data sets for the steam coefficients
<div style="border: 1px solid black; padding: 5px; width: fit-content;"> USER AREA: 52% used </div>	display of the occupancy of the coefficient memory
<div style="border: 1px solid black; padding: 5px; width: fit-content;"> Format NOW? no >YES< </div>	confirmation of the selected partition
<div style="border: 1px solid black; padding: 5px; width: fit-content;"> FORMATTING ... ■■■■■■ ... </div>	the coefficient memory is being partitioned
<p>SYSTEM settings\Libraries\Extended Library</p>	
<div style="border: 1px solid black; padding: 5px; width: fit-content;"> Libraries ⬆ Extended Library </div>	selection of the displays for the activation of the extended library
<div style="border: 1px solid black; padding: 5px; width: fit-content;"> Extended Library off >ON< </div>	activation of the extended library
<p>SYSTEM settings\Dialogs/Menus</p>	
<div style="border: 1px solid black; padding: 5px; width: fit-content;"> SYSTEM settings ⬆ Dialogs/Menus </div>	selection of the displays for the activation/deactivation or setting of the menu items in the other program branches
<div style="border: 1px solid black; padding: 5px; width: fit-content;"> Pipe Circumfer. off >ON< </div>	activation of the menu item for the input of the pipe circumference in the program branch Parameter x
<div style="border: 1px solid black; padding: 5px; width: fit-content;"> Fluid pressure off >ON< </div>	activation of the menu item for the input of the medium pressure in the program branch Parameter
<div style="border: 1px solid black; padding: 5px; width: fit-content;"> Meas.Point No.: (1234) >(↑↓←→)< </div>	selection of the input mode for the measuring point number in the program branch Measuring: (1234): digits, point, hyphen (↑↓←→): ASCII editor

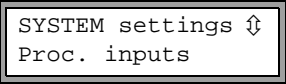
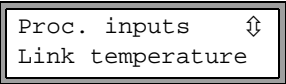
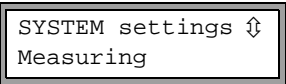
	cold start resistant
<div style="border: 1px solid black; padding: 5px; margin-bottom: 10px;"> Sound Path auto >USER< </div>	setting of the display for the input of the sound path in the program branch <i>Measuring</i> : <ul style="list-style-type: none"> • user: a value for the number of sound paths will be recommended. This value can be changed. • auto: selection of reflection mode or diagonal mode. recommended setting: user
<div style="border: 1px solid black; padding: 5px; margin-bottom: 10px;"> Transd. Distance auto >USER< </div>	setting for the display for the input of the transducer distance in the program branch <i>Measuring</i> : <ul style="list-style-type: none"> • user: only the entered transducer distance will be displayed if the recommended and the entered transducer distances are identical • auto: only the recommended transducer distance will be displayed recommended setting: user
<div style="border: 1px solid black; padding: 5px; margin-bottom: 10px;"> Steam in inlet off >ON< </div>	activation of the menu item for the input of the supply pressure in the program branch <i>Parameter</i> for a heat flow measurement in a medium that can be a liquid or a gas in the supply line x
<div style="border: 1px solid black; padding: 5px; margin-bottom: 10px;"> Time-progr.Meas. off >ON< </div>	activation of a time-programmable measurement, i.e. start of the measurement at a later time x
<div style="border: 1px solid black; padding: 5px; margin-bottom: 10px;"> Tx Corr.Offset off >ON< </div>	activation of the menu item for the input of a correction value (offset) for each temperature input in the program branch <i>Measuring</i>
<div style="border: 1px solid black; padding: 5px; margin-bottom: 10px;"> Error-val. delay damping >EDIT< </div>	selection of the error value delay <ul style="list-style-type: none"> • damping: The damping factor will be used. • edit: The menu item for the input of the error value delay in the program branch <i>Output Options</i> will be activated. x
<div style="border: 1px solid black; padding: 5px;"> SHOW RELAIS STAT off >ON< </div>	activation of the display of the alarm state during the measurement x

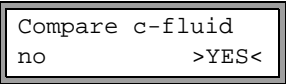
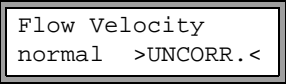
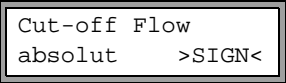
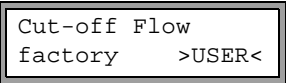
		cold start resistant
SYSTEM settings\Proc. inputs		
	selection of the displays for the setting of the inputs of the transmitter	
	assignment of temperature inputs and other inputs to the measuring channels	
SYSTEM settings\Measuring		
	selection of the displays for the settings of the measurement	
	activation of the WaveInjector (optional)	
	activation of the display for the difference between the measured and the expected sound velocity of a selected reference medium during the measurement	
	selection whether the flow velocity is displayed and transmitted with or without profile correction	x
	selection of the input of a lower limit for the flow velocity: <ul style="list-style-type: none"> absolut: independent of the flow direction sign: dependent on the flow direction 	x
	activation of the input of a lower limit of the flow velocity: <ul style="list-style-type: none"> factory: the default limit of 2.5 cm/s will be used user: input of a limit 	

	cold start resistant
<div style="border: 1px solid black; padding: 5px; margin-bottom: 10px;"> +Cut-off Flow 2.5 cm/s </div> <p>input of the cut-off flow for positive measured values range: 0...12.7 cm/s (0.127 m/s), default: 2.5 cm/s (0.025 m/s) This display will only be indicated if Cut-off Flow = sign and Cut-off Flow = user has been selected.</p>	
<div style="border: 1px solid black; padding: 5px; margin-bottom: 10px;"> -Cut-off Flow -2.5 cm/s </div> <p>Input of the cut-off flow for negative measured values range: -12.7...0 cm/s default: -2.5 cm/s This display will only be indicated if Cut-off Flow = sign und Cut-off Flow = user has been selected.</p>	
<div style="border: 1px solid black; padding: 5px; margin-bottom: 10px;"> Cut-off Flow 2.5 cm/s </div> <p>Input of the cut-off flow for the absolute value of the measured values range: 0...12.7 cm/s default: 2.5 cm/s This display will only be indicated if Cut-off Flow = absolut und Cut-off Flow = user has been selected.</p>	
<div style="border: 1px solid black; padding: 5px; margin-bottom: 10px;"> Velocity limit 0.0 m/s </div> <p>input of an upper limit of the flow velocity range: 0.1...25.5 m/s All measured values that are greater than the limit will be marked as outliers. Input of 0 (zero) switches off the detection for outliers.</p>	x
<div style="border: 1px solid black; padding: 5px; margin-bottom: 10px;"> Heat Quantity >[J]< [Wh] </div> <p>selection of the unit of measurement for the heat quantity</p>	x
<div style="border: 1px solid black; padding: 5px;"> heat+flow quant. off >ON< </div> <p>activation of the output and storing of the heat quantity totalizer values during the heat flow measurement</p>	x

		cold start resistant
<div style="border: 1px solid black; padding: 2px; width: fit-content;"> Quant. wrapping off >ON< </div>	activation of the overflow of the totalizers	X
<div style="border: 1px solid black; padding: 2px; width: fit-content;"> Quantity recall off >ON< </div>	activation of the taking-over of the totalizer values after a restart of the measurement	X
SYSTEM settings\Proc. outputs		
<div style="border: 1px solid black; padding: 2px; width: fit-content;"> SYSTEM settings ⇅ Proc. outputs </div>	selection of the displays for the setting of the outputs of the transmitter	
<div style="border: 1px solid black; padding: 2px; width: fit-content;"> Install Output ⇅ Current I1 </div>	selection of the output to be installed	
SYSTEM settings\Storing		
<div style="border: 1px solid black; padding: 2px; width: fit-content;"> SYSTEM settings ⇅ Storing </div>	selection of the displays for the storing of measured values in the data logger	
<div style="border: 1px solid black; padding: 2px; width: fit-content;"> Ringbuffer off >ON< </div>	setting of the overflow behavior of the data logger	X
<div style="border: 1px solid black; padding: 2px; width: fit-content;"> Storage mode sample >AVERAGE< </div>	selection of the sample mode <ul style="list-style-type: none"> • sample: storing and online output of the displayed measured value • average: storing and online output of the average of all measured values of a storage interval 	X
<div style="border: 1px solid black; padding: 2px; width: fit-content;"> Quantity Storage one >BOTH< </div>	setting of the storing behavior of the totalizers <ul style="list-style-type: none"> • one: the value of the totalizer that is currently displayed will be stored • both: one value for each flow direction will be stored 	X

		cold start resistant
<div style="border: 1px solid black; padding: 5px; width: fit-content;"> Store Amplitude off >ON< </div>	activation of the storing of the signal amplitude The value will only be stored if the data logger is activated.	x
<div style="border: 1px solid black; padding: 5px; width: fit-content;"> Store c-Medium off >ON< </div>	activation of the storing of the sound velocity of the medium The value will only be stored if the data logger is activated.	x
<div style="border: 1px solid black; padding: 5px; width: fit-content;"> Beep on storage >ON< off </div>	activation of an acoustic signal every time a measured value is stored or transmitted	x
SYSTEM settings\Serial transmis.		
<div style="border: 1px solid black; padding: 5px; width: fit-content;"> SYSTEM settings ⇕ serial transmis. </div>	selection of the displays for the formatting of the serial transmission of measured values	
<div style="border: 1px solid black; padding: 5px; width: fit-content;"> SER:kill spaces off >ON< </div>	activation of the serial transmission with/without blanks	
<div style="border: 1px solid black; padding: 5px; width: fit-content;"> SER:decimalpoint '.' >' '< </div>	selection of the decimal marker for floating point numbers	
<div style="border: 1px solid black; padding: 5px; width: fit-content;"> SER:col-separat. ';' >'TAB'< </div>	selection of the character for column separation	
SYSTEM settings\Miscellaneous		
<div style="border: 1px solid black; padding: 5px; width: fit-content;"> SYSTEM settings ⇕ Miscellaneous </div>	selection of the display for the setting of the contrast	
<div style="border: 1px solid black; padding: 5px; width: fit-content;"> SETUP DISPLAY ← CONTRAST → </div>	setting of the contrast of the display	

	cold start resistant
<p>Instrum. Inform.</p>	
<pre>Special Funct. ⬆ Instrum. Inform.</pre>	<p>selection of the displays for information about the transmitter</p>
<pre>F601-XXXXXXXX Free: 18327</pre>	<p>display of the type, serial number and available data logger capacity</p>
<pre>F601-XXXXXXXX V x.xx dd.mm.yy</pre>	<p>display of the type, serial number and firmware version with the date (dd - day, mm - month, yy - year)</p>
<p>STORE CURR.REC.</p>	
<pre>Special Funct. ⬆ Store Curr.Rec.</pre>	<p>selection of the displays for the storing of a parameter record This menu item can only be selected if the parameters have been entered in the program branch <code>Parameter</code>.</p>
<pre>Store Par. To: ⬆ Par.Record 01</pre>	<p>selection of the number for a parameter record</p>
<pre>Overwrite no >YES<</pre>	<p>confirmation of overwriting of an existing parameter record This display will only be indicated if the selected number already contains a parameter record.</p>
<p>Delete Para.Rec.</p>	
<pre>Special Funct. ⬆ Delete Para.Rec.</pre>	<p>selection of the displays for the deleting of a parameter record</p>
<pre>Delete: ⬆ Par.Record 01</pre>	<p>selection of the number of the parameter record to be deleted This display will only be indicated if a parameter set already exists.</p>

	cold start resistant
<div style="border: 1px solid black; padding: 5px; margin-bottom: 10px;">Really Delete? no >YES<</div> <p>Print Meas.Val.</p>	<p>confirmation for the deleting of a parameter record</p>
<div style="border: 1px solid black; padding: 5px; margin-bottom: 10px;">Special Funct. ⬆ Print Meas.Val.</div>	<p>selection of the displays for the transmission of stored measured values to a PC</p>
<div style="border: 1px solid black; padding: 5px; margin-bottom: 10px;">Send Header 01</div>	<p>start of the transmission of measured values This display will only be indicated if the data logger contains measured values and the transmitter is connected to a PC via a serial cable.</p>
<div style="border: 1px solid black; padding: 5px; margin-bottom: 10px;">■■■■■</div>	<p>display of the data transmission progress</p>
<p>Delete Meas.Val.</p>	
<div style="border: 1px solid black; padding: 5px; margin-bottom: 10px;">Special Funct. ⬆ Delete Meas.Val.</div>	<p>selection of the displays for the deleting of stored measured values</p>
<div style="border: 1px solid black; padding: 5px; margin-bottom: 10px;">Really Delete? no >YES<</div>	<p>confirmation for the deleting of measured values This display will only be indicated if measured values are stored in the data logger.</p>
<p>Battery status</p>	
<div style="border: 1px solid black; padding: 5px; margin-bottom: 10px;">Special Funct. ⬆ Battery status</div>	<p>selection of the displays for the charging of the battery</p>
<div style="border: 1px solid black; padding: 5px; margin-bottom: 10px;">■■■■■ ?73%- RELEARN! Cy: 24</div>	<p>display of the charge state of the battery If RELEARN is displayed, a relearn cycle is recommended.</p>
<div style="border: 1px solid black; padding: 5px; margin-bottom: 10px;">■■■ 30%- Cy: 1</div>	<p>display of the charge state of the battery</p>

	cold start resistant
<div style="border: 1px solid black; padding: 5px; margin-bottom: 10px;"> POWER OFF IN 10 s </div>	message that the transmitter will be switched off soon
<div style="border: 1px solid black; padding: 5px; margin-bottom: 10px;"> ■ LOW BATTERY WHILE POWER OFF </div>	message when the transmitter is switched on that the transmitter had been switched off automatically due to a low charge state
<div style="border: 1px solid black; padding: 5px; margin-bottom: 10px;"> LOW BATTERY ! </div>	message that the battery is almost empty
Install Material	
<div style="border: 1px solid black; padding: 5px; margin-bottom: 10px;"> Special Funct. ⬆ Install Material </div>	selection of the displays for the input of the pipe and lining materials
Install Material with Special Funct.\SYSTEM settings\ Libraries\Extended Library = off	
<div style="border: 1px solid black; padding: 5px; margin-bottom: 10px;"> Install Material >EDIT< delete </div>	selection whether a user defined material is to be edited or deleted
<div style="border: 1px solid black; padding: 5px; margin-bottom: 10px;"> USER Material ⬆ #01:--not used-- </div>	selection of a user defined material
<div style="border: 1px solid black; padding: 5px; margin-bottom: 10px;"> EDIT TEXT (⬆⬇⬅⬆⬅) USER MATERIAL 1 </div>	input of a designation for the selected material
<div style="border: 1px solid black; padding: 5px; margin-bottom: 10px;"> c-Material 1590.0 m/s </div>	input of the sound velocity of the material range: 600...6553.5 m/s
<div style="border: 1px solid black; padding: 5px; margin-bottom: 10px;"> Roughness 0.4 mm </div>	input of the roughness of the material

	cold start resistant
<p>Install Material with Special Funct.\SYSTEM settings\ Libraries\Extended Library = on</p>	
<pre> Edit Material ⇅ Basics:Y=m*X +n </pre>	<p>selection of the function for the temperature and pressure dependency of the material properties</p>
<pre> USER Material ⇅ #01:--not used-- </pre>	<p>selection of a user defined material</p>
<pre> USER Material 2 >EDIT< delete </pre>	<p>selection whether the user defined material is to be edited or deleted This display will only be indicated if the selected material already exists.</p>
<pre> #2: Input Name: USER MATERIAL 2 </pre>	<p>input of a designation for the selected material</p>
<pre> T-SOUNDSP. 1500.0 m/s </pre>	<p>input of the constants for the transversal sound velocity of the material The number of constants depends on the function selected above.</p>
<pre> L-SOUNDSP. 1500.0 m/s </pre>	<p>input of the constants for the longitudinal sound velocity of the material The number of constants depends on the function selected above.</p>
<pre> Default soundsp. long. >TRANS.< </pre>	<p>selection of the sound wave type for the flow measurement</p>
<pre> Roughness 0.4 mm </pre>	<p>input of the roughness of the material</p>
<pre> Save changes no >YES< </pre>	<p>confirmation that the changes are to be stored This display will only be indicated if a new material has been entered or the properties of an existing material have been changed.</p>

	cold start resistant
<p>Install Medium</p>	
<div style="border: 1px solid black; padding: 5px;"> Special Funct. ⬆ Install Medium </div>	selection of the displays for the input of media
<p>Install Medium with Special Funct.\SYSTEM settings\ Libraries\Extended Library = off</p>	
<div style="border: 1px solid black; padding: 5px;"> Install Medium >EDIT< delete </div>	selection whether a user defined medium is to be edited or deleted
<div style="border: 1px solid black; padding: 5px;"> USER Medium ⬆ #01:--not used-- </div>	selection of a user defined medium
<div style="border: 1px solid black; padding: 5px;"> EDIT TEXT (↑↓←→) USER MEDIUM 1 </div>	input of a designation for the selected medium
<div style="border: 1px solid black; padding: 5px;"> c-Medium MIN 1400.0 m/s </div>	input of the min. sound velocity of the medium range: 800...3500 m/s
<div style="border: 1px solid black; padding: 5px;"> c-Medium MAX 1550.0 m/s </div>	input of the max. sound velocity of the medium
<div style="border: 1px solid black; padding: 5px;"> Kinem.Viscosity 1.01 mm²/s </div>	input of the kinematic viscosity of the medium range: 0.01...30 000.00 mm ² /s
<div style="border: 1px solid black; padding: 5px;"> Density 1.00 g/cm³ </div>	input of the operating density of the medium
<p>Install Medium with Special Funct.\SYSTEM settings\ Libraries\Extended Library = on</p>	
<div style="border: 1px solid black; padding: 5px;"> Edit Medium ⬆ Basics:Y=m*X +n </div>	selection of the function for the temperature and pressure dependency of the medium properties

	cold start resistant
<div style="border: 1px solid black; padding: 2px; margin-bottom: 5px;"> USER Medium ⬆ #01:--not used-- </div> <div style="border: 1px solid black; padding: 2px; margin-bottom: 5px;"> USER MEDIUM 2 >EDIT< delete </div> <div style="border: 1px solid black; padding: 2px; margin-bottom: 5px;"> #2: Input Name: USER MEDIUM 2 </div> <div style="border: 1px solid black; padding: 2px; margin-bottom: 5px;"> SOUNDSPEED 1500.0 m/s </div> <div style="border: 1px solid black; padding: 2px; margin-bottom: 5px;"> VISCOSITY 1.0 mm²/s </div> <div style="border: 1px solid black; padding: 2px; margin-bottom: 5px;"> DENSITY 1.0 g/cm³ </div> <div style="border: 1px solid black; padding: 2px;"> Save changes no >YES< </div>	<p>selection of a user defined medium</p> <p>selection whether the user defined medium is to be edited or deleted This display will only be indicated if the selected medium already exists.</p> <p>input of a designation for the selected medium</p> <p>input of the constants for the longitudinal sound velocity of the medium The number of constants depends on the function selected above.</p> <p>input of the kinematic viscosity of the medium</p> <p>input of the operating density of the medium</p> <p>confirmation that the changes are to be stored This display will only be indicated if a new medium has been entered or the properties of an existing medium have been changed.</p>
After the input of HotCode 071001	
<div style="border: 1px solid black; padding: 2px;"> DNmin Q-Sensor 15 mm </div>	<p>input of the lower limit of the inner pipe diameter for the displayed transducer type range: 3...63 mm</p> <p style="text-align: right;">x</p>

B Technical Data

Flow Transmitter

FLUXUS	F601
design	portable
measurement	
measuring principle	transit time difference correlation principle, automatic NoiseTrek selection for measurements with high gaseous or solid content
flow velocity	0.01...25 m/s
repeatability	0.15 % of reading ± 0.01 m/s
medium	all acoustically conductive liquids with < 10 % gaseous or solid content by volume (transit time difference principle)
temperature compensation	corresponding to the recommendations in ANSI/ASME MFC-5M-1985
accuracy¹	
with standard calibration	± 1.6 % of reading ± 0.01 m/s
with extended calibration (optional)	± 1.2 % of reading ± 0.01 m/s
with field calibration ²	± 0.5 % of reading ± 0.01 m/s
flow transmitter	
power supply	100...240 V/50...60 Hz (power supply), 10.5...15 V DC (socket at transmitter) or integrated battery
battery	Li-Ion, 7.2 V/4.5 Ah operating time (without outputs, inputs and backlight): > 14 h
power consumption	< 6 W
number of flow measuring channels	2
signal damping	0...100 s, adjustable
measuring cycle (1 channel)	100...1000 Hz
response time	1 s (1 channel), optional: 70 ms
housing material	PA, TPE, AutoTex, stainless steel
degree of protection according to EN 60529	IP 65
weight	1.9 kg
fixation	QuickFix pipe mounting fixture
operating temperature	-10...+60 °C
display	2 x 16 characters, dot matrix, backlit
menu language	English, German, French, Dutch, Spanish

¹ for transit time difference principle, reference conditions and $v > 0.15$ m/s

² reference uncertainty < 0.2 %

FLUXUS	F601
measuring functions	
physical quantities	volumetric flow rate, mass flow rate, flow velocity, heat flow (if temperature inputs are installed)
totalizers	volume, mass, optional: heat quantity
calculation functions	average, difference, sum
diagnostic functions	sound velocity, signal amplitude, SNR, SCNR, standard deviation of amplitudes and transit times
data logger	
loggable values	all physical quantities, totaled values and diagnostic values
capacity	> 100 000 measured values
communication	
interface	RS232/USB
serial data kit	
software (all Windows™ versions)	- FluxData: download of measured data, graphical presentation, conversion to other formats (e.g. for Excel™) - FluxKoef: creating medium data sets
cable	RS232
adapter	RS232 - USB
transport case	
dimensions	500 x 400 x 190 mm
outputs	
	The outputs are galvanically isolated from the transmitter.
number	max. on request
accessories	output adapter (if number of outputs > 4)
current output	
range	0/4...20 mA
accuracy	0.1 % of reading ±15 µA
active output	$R_{ext} < 200 \Omega$
passive output	$U_{ext} = 4...16 \text{ V}$, dependent on R_{ext} $R_{ext} < 500 \Omega$
frequency output	
range	0...5 kHz
open collector	24 V/4 mA
binary output	
optorelay	26 V/100 mA
binary output as alarm output - functions	limit, change of flow direction or error
binary output as pulse output - pulse value - pulse width	0.01...1000 units 1...1000 ms

FLUXUS	F601
inputs	
	The inputs are galvanically isolated from the transmitter.
number	max. 4
accessories	input adapter (if number of inputs > 2)
temperature input	
designation	Pt100/Pt1000
connection	4-wire
range	-150...+560 °C
resolution	0.01 K
accuracy	±0.01 % of reading ±0.03 K
current input	
accuracy	0.1 % of reading ±10 µA
passive input	$R_i = 50 \Omega$, $P_i < 0.3 \text{ W}$
- range	-20...+20 mA
voltage input	
range	0...1 V
accuracy	0.1 % of reading ±1 mV
internal resistance	$R_i = 1 \text{ M}\Omega$

Dimensions

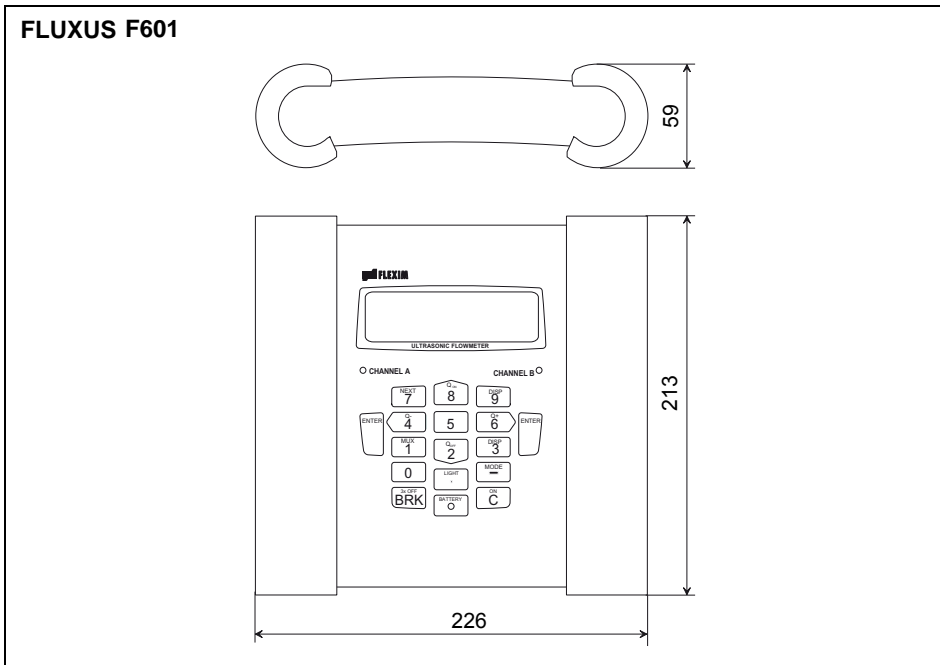

in mm

Shear Wave Transducers

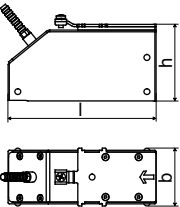
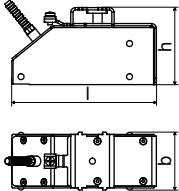
technical type		CDG1NZ7	CLG1NZ7	CDK1NZ7	CLK1NZ7
order code		FSG-NNNNL	FSG-NNNNL/LC	FSK-NNNNL	FSK-NNNNL/LC
transducer frequency	MHz	0.2	0.2	0.5	0.5
inner pipe diameter d					
min. extended	mm	400	400	100	100
min. recommended	mm	500	500	200	200
max. recommended	mm	6500	6500	3600	3600
max. extended	mm	6500	6500	6500	6500
pipe wall thickness					
min.	mm	-	-	-	-
max.	mm	-	-	-	-
material					
housing		PEEK with stainless steel cap 304 (1.4301)	PEEK with stainless steel cap 304 (1.4301)	PEEK with stainless steel cap 304 (1.4301)	PEEK with stainless steel cap 304 (1.4301)
contact surface		PEEK	PEEK	PEEK	PEEK
degree of protection according to EN 60529		IP 67	IP 67	IP 67	IP 67
transducer cable					
type		1699	1699	1699	1699
length	m	5	9	5	9
dimensions					
length l	mm	129.5	129.5	126.5	126.5
width b	mm	51	51	51	51
height h	mm	67	67	67.5	67.5
dimensional drawing					
operating temperature					
min.	°C	-40	-40	-40	-40
max.	°C	+130	+130	+130	+130
temperature compensation		x	x	x	x

Shear Wave Transducers

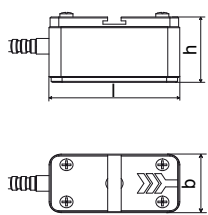
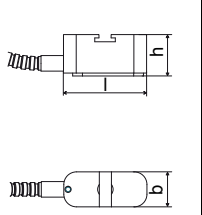
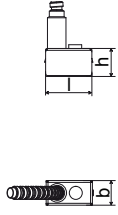
technical type		CDM1NZ7	CDQ1NZ7	CDS1NZ7
order code		FSM-NNNNL	FSQ-NNNNL	FSS-NNNNL
transducer frequency	MHz	1	4	8
inner pipe diameter d				
min. extended	mm	50	10	6
min. recommended	mm	100	25	10
max. recommended	mm	2000	150	70
max. extended	mm	3400	400	70
pipe wall thickness				
min.	mm	-	-	-
max.	mm	-	-	-
material				
housing		stainless steel 304 (1.4301)	stainless steel 304 (1.4301)	stainless steel 304 (1.4301)
contact surface		PEEK	PEEK	PEI
degree of protection according to EN 60529		IP 67	IP 67	IP 65
transducer cable				
type		1699	1699	1699
length	m	4	3	2
dimensions				
length l	mm	60	42.5	25
width b	mm	30	18	13
height h	mm	33.5	21.5	17
dimensional drawing				
operating temperature				
min.	°C	-40	-40	-30
max.	°C	+130	+130	+130
temperature compensation		x	x	x

Shear Wave Transducers (extended temperature range)

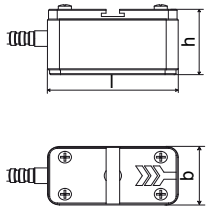
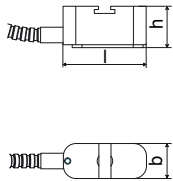
technical type		CDM1EZ7	CDQ1EZ7
order code		FSM-ENNLL	FSQ-ENNLL
transducer frequency	MHz	1	4
inner pipe diameter d			
min. extended	mm	50	10
min. recommended	mm	100	25
max. recommended	mm	2000	150
max. extended	mm	3400	400
pipe wall thickness			
min.	mm	-	-
max.	mm	-	-
material			
housing		stainless steel 304 (1.4301)	stainless steel 304 (1.4301)
contact surface		Sintimid	Sintimid
degree of protection according to EN 60529		IP 65	IP 65
transducer cable			
type		1699	1699
length	m	4	3
dimensions			
length l	mm	60	42.5
width b	mm	30	18
height h	mm	33.5	21.5
dimensional drawing			
operating temperature			
min.	°C	-30	-30
max.	°C	+200	+200
temperature compensation		x	x

Lamb Wave Transducers

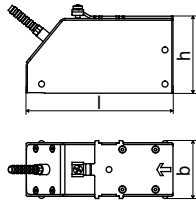
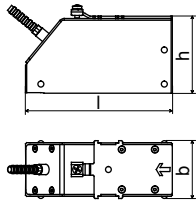
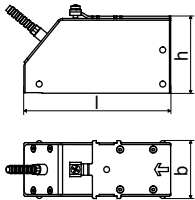
technical type		CRG1NC3	CRH1NC3	CRK1NC3
order code		FLG-NNNNL	FLH-NNNNL	FLK-NNNNL
transducer frequency	MHz	0.2	0.3	0.5
inner pipe diameter d				
min. extended	mm	500	400	220
min. recommended	mm	600	450	250
max. recommended	mm	5000	3500	2100
max. extended	mm	6500	5000	4500
pipe wall thickness				
min.	mm	14	9	5
max.	mm	27	18	11
material				
housing		PPSU with stainless steel cap 304 (1.4301)	PPSU with stainless steel cap 304 (1.4301)	PPSU with stainless steel cap 304 (1.4301)
contact surface		PPSU	PPSU	PPSU
degree of protection according to EN 60529		IP 65	IP 65	IP 65
transducer cable				
type		1699	1699	1699
length	m	5	5	5
dimensions				
length l	mm	128.5	128.5	128.5
width b	mm	51	51	51
height h	mm	67.5	67.5	67.5
dimensional drawing				
operating temperature				
min.	°C	-40	-40	-40
max.	°C	+170	+170	+170
temperature compensation		x	x	x

Lamb Wave Transducers

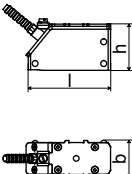
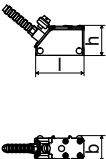
technical type		CRM1NC3	CRQ1NC3
order code		FLM-NNNNL	FLQ-NNNNL
transducer frequency	MHz	1	4
inner pipe diameter d			
min. extended	mm	70	10
min. recommended	mm	120	25
max. recommended	mm	1000	100
max. extended	mm	2000	400
pipe wall thickness			
min.	mm	3	0.5
max.	mm	5	1
material			
housing		PPSU with stainless steel cap 304 (1.4301)	PPSU with stainless steel cap 304 (1.4301)
contact surface		PPSU	PPSU
degree of protection according to EN 60529		IP 65	IP 65
transducer cable			
type		1699	1699
length	m	4	3
dimensions			
length l	mm	74	42
width b	mm	32	22
height h	mm	40.5	25.5
dimensional drawing			
operating temperature			
min.	°C	-40	-40
max.	°C	+170	+170
temperature compensation		x	x

Units of Measurement

volumetric flow rate	flow velocity	mass flow rate	totalizers		sound velocity	heat quantity	heat flow
			volume	mass			
m ³ /d	m/s	kg/h	m ³	g	m/s	J	kW
m ³ /h	cm/s	kg/min	l	kg		Wh	
m ³ /min	inch/s	g/s	gal	t			
m ³ /s	fps	t/d					
ml/min		t/h					
l/h		lb/d					
l/min		lb/h					
l/s		lb/min					
hl/h		lb/s					
hl/min							
hl/s							
MI/d							
bb/d							
bb/h							
bb/m							
USgpd							
USgph							
USgpm							
USgps							
MGD							
CFD							
CFH							
CFM							
CFS							

1 US gallon = 3.78 l

1 barrel = 42 US gallons = 158.76 l

Flow Nomogram (metrical)

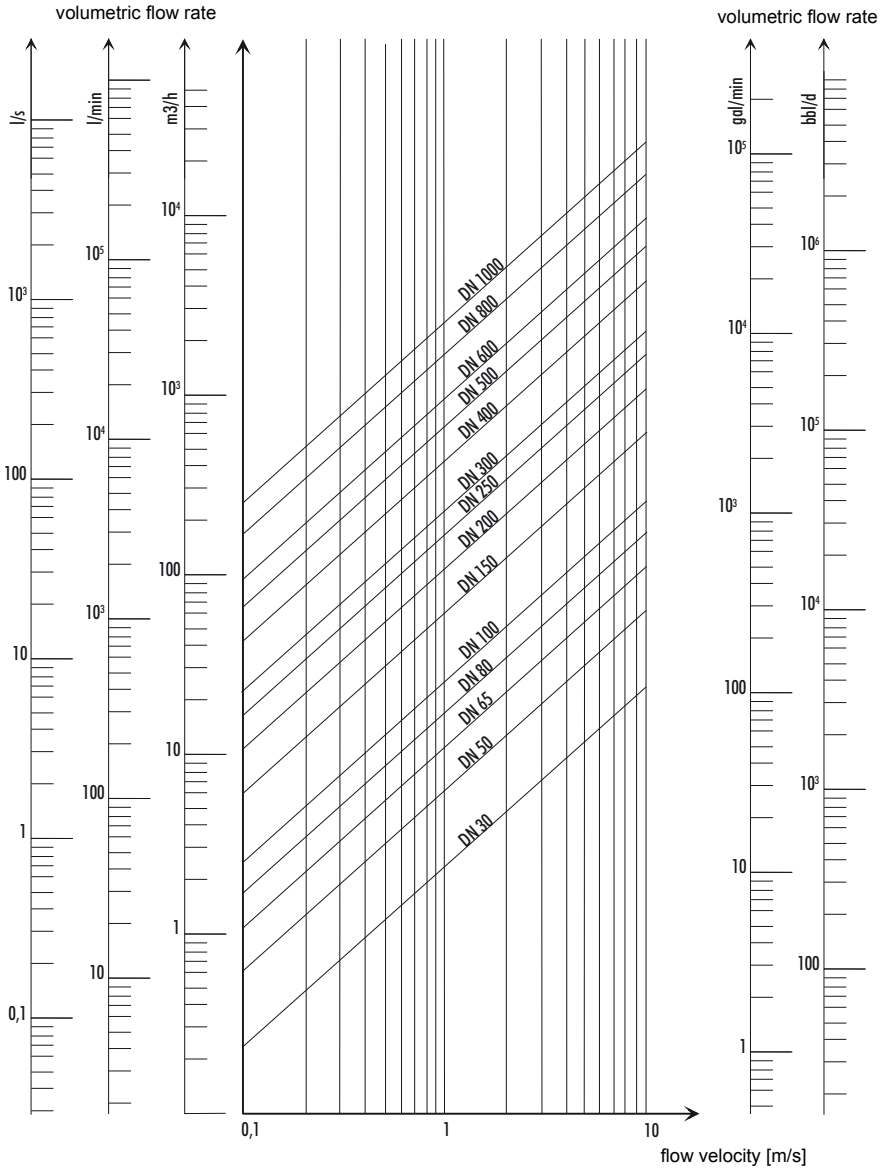

Flow Nomogram (imperial)

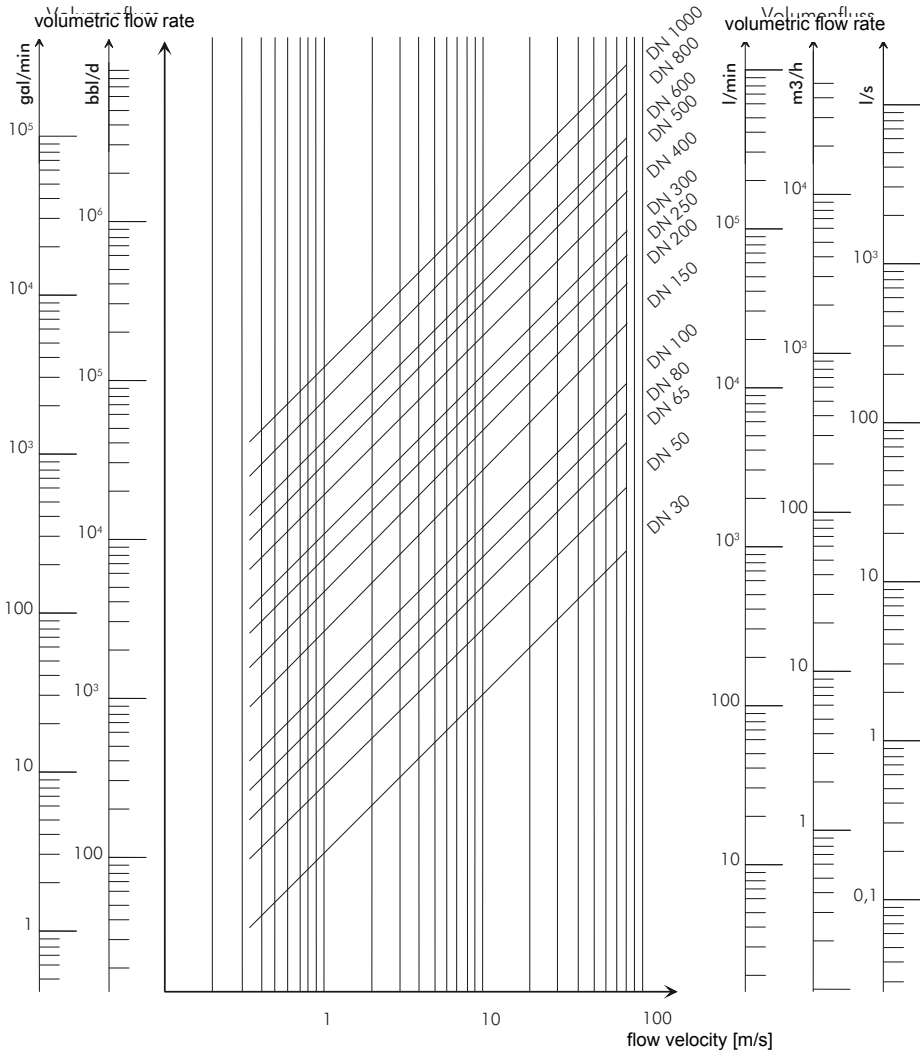

C Reference

The following tables provide assistance for the user. The accuracy of the data depends on the composition, the temperature and the manufacturing process of the material. FLEXIM does not assume liability for any inaccuracies.

Table C.1: Sound Velocity of Selected Pipe and Lining Materials at 20 °C

The values of some of these materials are stored in the internal database of the transmitter. Column c_{flow} shows the sound velocity (longitudinal or transversal) used for the flow measurement.

material	c_{trans} [m/s]	c_{long} [m/s]	c_{flow}	material	c_{trans} [m/s]	c_{long} [m/s]	c_{flow}
aluminum	3 100	6 300	trans	platinum	1 670		trans
asbestos ce- ment	2 200		trans	polyethylene	925		trans
lead	700	2 200	trans	polystyrene	1 150		trans
bitumen	2 500		trans	PP	2 600		trans
brass	2 100	4 300	trans	PVC		2 395	long
carbon steel	3 230	5 800	trans	PVC (hard)	948		trans
copper	2 260	4 700	trans	PVDF	760	2 050	long
Cu-Ni-Fe	2 510		trans	quartz glass	3 515		trans
ductile iron	2 650		trans	rubber	1 900	2 400	trans
glass	3 400	4 700	trans	silver	1 590		trans
grey cast iron	2 650	4 600	trans	Sintimid		2 472	long
PE		1 950	long	stainless steel	3 230	5 790	trans
Perspex	1 250	2 730	long	Teka PEEK		2 537	long
PFA		1 185	long	Tekason		2 230	long
plastics	1 120	2 000	long	titanium	3 067	5 955	trans

The sound velocity depends on the composition and the manufacturing process of the material.

The sound velocity of alloys and cast materials fluctuates strongly. The values only serve as an orientation.

Table C.2: Typical Roughnesses of Pipes

The values are based on experience and measurements.

material	absolute roughness [mm]
drawn pipes of non-ferrous metal, glass, plastics and light metal	0...0.0015
drawn steel pipes	0.01...0.05
fine-planed, polished surface	max. 0.01
planed surface	0.01...0.04
rough-planed surface	0.05...0.1
welded steel pipes, new	0.05...0.1
after long use, cleaned	0.15...0.2
moderately rusted, slightly encrusted	max. 0.4
heavily encrusted	max. 3
cast iron pipes:	
bitumen lining	> 0.12
new, without lining	0.25...1
rusted	1...1.5
encrusted	1.5...3

Table C.3: Typical Properties of Selected Media at 20 °C and 1 bar

medium	sound velocity [m/s]	kinematic viscosity [mm ² /s]	density [g/cm ³]
acetone	1 190	0.4	0.7300
ammonia (NH ₃)	1 386	0.2	0.6130
gasoline	1 295	0.7	0.8800
beer	1 482	1.0	0.9980
BP Transcal LT	1 365	20.1	0.8760
BP Transcal N	1 365	94.3	0.8760
diesel	1 210	7.1	0.8260
ethanol	1 402	1.5	0.7950
hydrofluoric acid 50 %	1 221	1.0	0.9980
hydrofluoric acid 80 %	777	1.0	0.9980
glycol	1 665	18.6	1.1100
20 % glycol/H ₂ O	1 655	1.7	1.0280
30 % glycol/H ₂ O	1 672	2.2	1.0440
40 % glycol/H ₂ O	1 688	3.3	1.0600
50 % glycol/H ₂ O	1 705	4.1	1.0750
ISO VG 100	1 487	314.2	0.8690
ISO VG 150	1 487	539.0	0.8690
ISO VG 22	1 487	50.2	0.8690
ISO VG 220	1 487	811.1	0.8690
ISO VG 32	1 487	78.0	0.8690
ISO VG 46	1 487	126.7	0.8730
ISO VG 68	1 487	201.8	0.8750
methanol	1 119	0.7	0.7930
milk	1 482	5.0	1.00
Mobiltherm 594	1 365	7.5	0.8730
Mobiltherm 603	1 365	55.2	0.8590
NaOH 10 %	1 762	2.5	1.1140
NaOH 20 %	2 061	4.5	1.2230
paraffin 248	1 468	195.1	0.8450
R134 Freon	522	0.2	1.2400
R22 Freon	558	0.1	1.2130
crude oil, light	1 163	14.0	0.8130
crude oil, heavy	1 370	639.5	0.9220
sulphuric acid 30 %	1 526	1.4	1.1770
sulphuric acid 80 %	1 538	13.0	1.7950
sulphuric acid 96 %	1 366	11.5	1.8350
juice	1 482	1.0	0.9980
hydrochloric acid 25 %	1 504	1.0	1.1180
hydrochloric acid 37 %	1 511	1.0	1.1880
sea water	1 522	1.0	1.0240
Shell Thermina B	1 365	89.3	0.8630
silicone oil	1 019	14 746.6	0.9660
SKYDROL 500-B4	1 387	21.9	1.0570
SKYDROL 500-LD4	1 387	21.9	1.0570
Water	1 482	1.0	0.9990

Table C.4: Properties of Water at 1 bar and at Saturation Pressure

medium temperature [°C]	medium pressure [bar]	density [kg/m ³]	specific heat capacity* [kJ/kg/K-1]
0	1	999.8	4.218
10	1	999.7	4.192
20	1	998.3	4.182
30	1	995.7	4.178
40	1	992.3	4.178
50	1	988.0	4.181
60	1	983.2	4.184
70	1	977.7	4.190
80	1	971.6	4.196
90	1	965.2	4.205
100	1.013	958.1	4.216
120	1.985	942.9	4.245
140	3.614	925.8	4.285
160	6.181	907.3	4.339
180	10.027	886.9	4.408
200	15.55	864.7	4.497
220	23.20	840.3	4.613
240	33.48	813.6	4.769
260	46.94	784.0	4.983
280	64.20	750.5	5.29
300	85.93	712.2	5.762
320	112.89	666.9	6.565
340	146.05	610.2	8.233
360	186.75	527.5	14.58
374.15	221.20	315.5	∞

* at constant pressure

Table C.5: Chemical Resistance of Autotex

Autotex (keyboard) is resistant according to DIN 42115, part 2 against the following chemicals for a contact time of more than 24 h without visible changes:

- ethanol
- cyclohexanol
- diacetone alcohol
- glycol
- isopropanol
- glycerine
- methanol
- triacetin
- Dowandol DRM/PM
- acetone
- methyl-ethyl-ketone
- Dioxan
- cyclohexanone
- MIBK
- isophorone
- ammonia < 40 %
- soda lye < 40 %
- potassium hydroxide < 30 %
- alcalicarbonate
- bichromate
- potassium hexacyanoferrates
- acetonitrile
- sodium bisulfate
- formaldehyde 37...42 %
- acetaldehyde
- aliphatic hydrocarbons
- Toluol
- Xylol
- diluent (white spirit)
- formic acid < 50 %
- acetic acid < 50 %
- phosphoric acid < 30 %
- hydrochloric acid < 36 %
- nitric acid < 10 %
- trichloroacetic acid < 50 %
- sulphuric acid < 10 %
- drilling emulsion
- diesel oil
- varnish
- paraffin oil
- castor oil
- silicone oil
- turpentine oil substitute
- Dccon
- plane fuel
- gasoline
- Water
- saltwater
- 1,1,1-trichlorethane
- ethyl acetate
- diethyl ether
- N-butyl acetate
- amyl acetate
- butylcellosolve
- ether
- chlornatron < 20 %
- hydrogen peroxide < 25 %
- potash soft soap
- detergent
- tensides
- softener
- iron chloride (FeCl₂)
- iron chloride (FeCl₃)
- dibutyl phthalate
- dioctyl phthalate
- sodium carbonate

Autotex is resistant according to DIN 42115, part 2 to acetic acid for a contact time <1 h without visible damage.

Autotex is not resistant to following chemicals:

- concentrated mineral acids
- concentrated alkaline solutions
- high pressure steam > 100 °C
- benzyl alcohol
- methylene chloride

D Certificates



Declaration of conformity

We

FLEXIM Flexible Industriemesstechnik GmbH
Wolfener Str. 36
12681 Berlin
Germany,

declare under our sole responsibility that the ultrasonic flowmeter

FLUXUS F601

to which this declaration relates is in conformity with the EC directives

EMC Directive 2004/108/EC for Electromagnetic Compatibility
Low Voltage Directive 2006/95/EC for Electrical Safety.

The ultrasonic flowmeter is in conformity with the following European Standards:

Class	Standard	Description
EMC Directive	EN 61326-1:2006	Electrical equipment for measurement, control and laboratory use - EMC requirements
- Immunity	EN 61326-1	Electrical equipment for continuous, unattended operation
	EN 61000-4-2:1995 +A1:1998+A2:2001	Testing and measurement techniques; Electrostatic Discharge Immunity
	EN 61000-4-3:2003	Testing and measurement techniques; RF Field Immunity
	EN 61000-4-4:2005	Testing and measurement techniques; Electrical Fast Transient / Burst Immunity
	EN 61000-4-5:2007	Testing and measurement techniques; Surge Immunity Test
	EN 61000-4-6:2002	Testing and measurement techniques; RF Conducted Immunity
	EN 61000-4-11:2005	Testing and measurement techniques; AC Mains Voltage Dips and Interruption Immunity
- Emission	EN 61326-1:2007	Electrical equipment Class A
Low Voltage Directive	EN 61010-1:2002	Safety requirements for electrical equipment for measurement, control and laboratory use

The installation, operating and safety instructions have to be observed!

Berlin, 29/04/2008

Dipl.-Ing. Jens Hilpert
Managing Director