

Megger[®]



HVB 10

High Voltage Measuring Bridge

USER GUIDE

Issue: C (09/2025) - EN
Article number: 83041



Consultation with Megger

The present system manual has been designed as an operating guide and for reference. It is meant to answer your questions and solve your problems in as fast and easy a way as possible. Please start with referring to this manual should any trouble occur.

In doing so, make use of the table of contents and read the relevant paragraph with great attention. Furthermore, check all terminals and connections of the instruments involved.

Should any question remain unanswered or should you need the help of an authorized service station, please contact:

Megger Limited
 Archcliffe Road
 Kent CT17 9EN
 T: +44 1304 502100
 F: +44 1304 207342
 E: uksales@megger.com

Megger Germany GmbH (Baunach)
 Dr.-Herbert-lann-Str. 6
 D - 96148 Baunach
 T: +49 9544 68 – 0
 F: +49 9544 22 73
 E: team.dach@megger.com

Megger Germany GmbH (Radeburg)
 Röderaue 41
 D - 01471 Radeburg / Dresden

 T: +49 35208 84 – 0
 F: +49 35208 84 249
 E: team.dach@megger.com

Megger USA
 Valley Forge Corporate Centre
 2621 Van Buren Avenue
 Norristown, PA 19403 USA
 T: +1 610 676 8500
 F: +1 610 676 8610

© Megger

All rights reserved. No part of this handbook may be copied by photographic or other means unless Megger have before-hand declared their consent in writing. The information in this document is subject to change without notice and should not be construed as a commitment by Megger. Megger cannot be made liable for technical or printing errors or shortcomings of this handbook. Megger also disclaims all responsibility for damage resulting directly or indirectly from the delivery, supply, or use of this matter.

Terms of Warranty

Megger accept responsibility for a claim under warranty brought forward by a customer for a product sold by Megger under the terms stated below.

Megger warrant that at the time of delivery Megger products are free from manufacturing or material defects which might considerably reduce their value or usability. This warranty does not apply to faults in the software supplied. During the period of warranty, Megger agree to repair faulty parts or replace them with new parts or parts as new (with the same usability and life as new parts) according to their choice.

This warranty does not cover wear parts, lamps, fuses, batteries and accumulators.

Megger reject all further claims under warranty, in particular those from consequential damage. Each component and product replaced in accordance with this warranty becomes the property of Megger.

All warranty claims versus Megger are hereby limited to a period of 12 months from the date of delivery. Each component supplied by Megger within the context of warranty will also be covered by this warranty for the remaining period of time but for 90 days at least.

Each measure to remedy a claim under warranty shall exclusively be carried out by Megger or an authorized service station.

This warranty does not apply to any fault or damage caused by exposing a product to conditions not in accordance with this specification, by storing, transporting, or using it improperly, or having it serviced or installed by a workshop not authorized by Megger. All responsibility is disclaimed for damage due to wear, will of God, or connection to foreign components.

For damage resulting from a violation of their duty to repair or re-supply items, Megger can be made liable only in case of severe negligence or intention. Any liability for slight negligence is disclaimed.

Since some states do not allow the exclusion or limitation of an implied warranty or of consequential damage, the limitations of liability described above perhaps may not apply to you.

Contents

Consultation with Megger3

Terms of Warranty4

Contents5

1 Safety Instructions7

1.1 Basic Notes7

1.2 General Safety Instructions and Warnings.....8

2 Technical Description10

2.1 System Description10

2.2 Technical Data12

2.3 Connections, Controls and Display14

3 Commissioning15

3.1 Electrical Connection in Fault Prelocation Mode16

3.2 Electrical Connection in Testing, Burning and Pinpointing Mode18

3.3 Electrical Connection: Special Applications19

3.4 Use of an External Safety Device (Optional).....21

4 Operation22

4.1 Switching On the System22



4.2 General Operation.....22

4.3 Security Mechanisms24

4.4 System Settings25

4.5 Operating Modes.....26

4.5.1 Testing the Insulation - 26

4.5.2 Prelocating a Fault -  / 28

4.5.3 Pinpointing a Sheath Fault - 30

4.5.4 Burning - 32

4.6 Concluding the Test33

5 Processing Log Data.....34

6 Updating the Firmware35

7 Maintenance and Care36



1 Safety Instructions

1.1 Basic Notes

Safety precautions This handbook contains basic instructions for the commissioning and operation of the HVB 10. For this reason, it is important to ensure that the manual is always available to authorised and trained personnel. Operating personnel should read the manual thoroughly. The manufacturer will not be held liable for any injury or damage to personnel or property through failure to observe the safety precautions contained in this handbook.

The specific standards and regulations in each country must also be observed.

Labelling of safety instructions Important instructions concerning personnel, operational and technical safety are marked in the text as follows:

Symbol	Description
	Indicates a potential danger of an electric shock that may result in fatal or serious injury.
	Indicates a potential danger that may lead to slight or moderate injury.
	The notes contain important information and useful tips for using the system. Failure to observe them can render the measurement results useless.

Working with products from Megger It is important to observe the generally applicable electrical regulations of the country in which the device will be installed and operated, as well as the current national accident prevention regulations and internal company directives (work, operating and safety regulations).

After working on the system, it must be voltage-free and secured against reconnection as well as having been discharged, earthed and short-circuited.

Use genuine accessories to ensure system safety and reliable operation. The use of other parts is not permitted and invalidates the warranty.

Operating staff This system and its peripheral equipment may only be operated by trained or instructed personnel. Anyone else must be kept away.

The system may only be installed by an authorised electrician. DIN VDE 0104 (EN 50191), DIN VDE 0105 (EN 50110) and the German accident prevention regulations (UVV) define an electrician as someone whose knowledge, experience and familiarity with the applicable regulations enables him to recognise potential hazards.

Repair and maintenance Repair and maintenance work may only be performed by Megger or authorised service partners. Megger recommends having the system tested and maintained at a Megger service centre once a year.

Megger also offers its customers on-site service. Please contact your service centre as needed.

Electromagnetic radiation This device is designed for industrial use according to EN 55011. When used at home it could cause interference to other equipment, such as the radio or television.

The interference level from the line complies with the limit curve B (living area), the radiation level complies with the limit curve A (industrial area). Once the living area is sufficiently far away from the planned area of operation (industrial area), equipment there will not be impaired.

Lifting and carrying The device must only be lifted and carried using the handles provided on the top and side. Other parts of the device, such as the accessory bag or connecting cables, cannot withstand the forces caused by lifting the device and could break or tear off as a result.

1.2 General Safety Instructions and Warnings

Use only as intended The operating safety is only guaranteed if the delivered system is used as intended. Incorrect use may result in danger to the operator, to the system and the connected equipment.

The thresholds listed in the technical data may not be exceeded under any circumstances. Condensation during the operation of Megger products may result in danger to persons and devices through voltage arc-over. Prevent condensation before and during the measuring mode by cooling the measuring systems sufficiently. The operation of Megger products in direct contact with water, aggressive substances and inflammatory gases and vapours is prohibited.

The HVB 10 is built to be robust and can withstand the stresses it can expect to be subjected to in demanding everyday use. Nevertheless, it is a precision measuring device which needs to be treated with the appropriate care. This applies in particular to the connection cable and the clamps, which play an important role in ensuring the device remains safe while the results of measurements remain precise.

Procedure in the event that the device malfunctions The system may only be operated whilst it is in perfect working condition. In the event of damage, irregularities or malfunctions that cannot be resolved with the assistance of the operating instructions, the system must be shut down immediately and labeled accordingly. In such an event, the relevant management must be informed. Please contact Megger Service immediately, to eliminate the malfunction. The system may only be started up again once the malfunction has been eliminated.

Five safety rules

The five safety rules must always be followed when working with HV (High Voltage):

1. De-energise
2. Protect against re-energising
3. Confirm absence of voltage
4. Earth and short-circuit
5. Cover up or bar-off neighbouring energised parts



Using cardiac pacemaker / defibrillator

Physical processes during operation of high voltage may endanger persons wearing a cardiac pacemaker or defibrillator when near these high voltage facilities.

	<p>Fire fighting in electrical installations</p> <ul style="list-style-type: none"> • According to regulations, carbon dioxide (CO₂) is required to be used as extinguishing agent for fighting fire in electrical installations. • Carbon dioxide is electrically non conductive and does not leave residues. It is safe to be used in energized facilities as long as the minimum distances are maintained. A CO₂ fire extinguisher must be always available within electrical installations. • If, contrary to the regulations, any other extinguishing agent is used for fire fighting, this may lead to damage at the electrical installation. Megger disclaims any liability for consequential damage. Furthermore, when using a powder extinguisher near high-voltage installations, there is a danger that the operator of the fire extinguisher will get an electrical shock from a voltage arc-over (due to the powder dust created). • It is essential to observe the safety instruction on the extinguishing agent. • Applicable is DIN VDE 0132.
---	--

 <p>WARNING</p>	<p>Be careful when working with high voltage</p> <p>Working on high voltage systems and equipment – especially in non-stationary operation – requires particular care and safety-conscious action on the part of test personnel. VDE regulations 0104 on setting up and operating electrical test systems, as well as EN 50191 and national standards and regulations must be strictly adhered to.</p> <ul style="list-style-type: none"> • The System generates a dangerous voltage of up to 10. This is supplied via a HV connection cable to the test object. • The test system may not be operated without supervision. • Never fail to use safety equipment or put it out of operation. • To prevent dangerous charge accumulation, earth all metal parts in the vicinity of the high voltage equipment. • When high voltage is shut off, the cable under test is discharged by an internal discharge device. This discharge device is designed for a maximum test object capacity in compliance with the technical data. This value must not be exceeded. The discharge device may otherwise become damaged and charge may remain in the test object. The cable must therefore always be discharged in accordance with the applicable safety regulations, e.g. discharged using a discharge rod and then be shorted before the danger zone is accessed.
--	---

2 Technical Description

2.1 System Description

Intended use Due to its high measurement resolution and accuracy, the high voltage measuring bridge HVB 10 is supposed to be used to prelocate faults of the primary insulation that are difficult or impossible to locate using other methods like a pulse reflection measurements. Typical examples are high-resistive conductor faults in paper insulated (PILC) cables, faults in very long cables (long fault distance) and faults in cross-bonded cable systems.

Furthermore, the system permits in the easiest way the testing of cable sheaths and prelocation and pinpointing of cable sheath faults.

Function To test the integrity of the inner cable insulation or the sheath, the HVB 10 works in test mode with a voltage of up to 10 kV (negative polarity).

The prelocation of a detected fault takes place using the voltage drop method, in which the current, voltage and resistance before and after the fault location are determined and considered in relation to the cable length. The necessary measuring and calculation steps take place automatically and, after a few seconds, the distance to the fault is displayed. Due to the bipolar measurement, falsifying thermoelectric and galvanic influences can be detected and mathematically eliminated.

For sheath fault pinpointing, the device provides several possibilities. One of these is a pulsed DC output voltage, which is used in combination with an earth fault locator as the ESG to locate the sheath fault by the step voltage method. A second method is to pinpoint the fault with a so-called A-Frame while the HVB 10 transmits a low frequency (3 or 4.8 Hz) signal.



Features The HVB 10 combines the following features in a single device:

- Easy and comfortable operation via rotary encoder (EasyGo) and touch screen
- Bipolar measurement
- Two prelocation modes to cope with the different (fault type dependant) accuracy requirements
- Burning mode with manual control of the output voltage, selectable current limit and up to 200 mA of continuous output current (max. 5 minutes)
- Pinpointing with pulsed DC voltage
- Fully automatic measurement
- Independent from the resistance of supplementary wires and test leads
- Detection of incorrect hook-up to cable under test
- Fault locating of high resistive faults inside cables
- Detection, storage and data recording of fast processes (wipers, breakdowns)
- Logging and log data export to MeggerBook Lite software via USB
- Integrated discharge with active overload protection
- High-performance battery for power supply independent of the mains
- Robust IP53 trolley case with extendable handle
- Wide range input for the voltage supply

Scope of delivery The scope of delivery of the system includes the following:

- HVB 10
- HV connection cable (incl. aligator clips), 4 m
- Mains connection lead, 2.5 m
- Earthing lead, 5 m
- 2 x Kelvin clip for HV cable terminations, red
- 4 x aligator clip for HV cable terminations, black
- 2 x measuring leads (incl. aligator clips), 0.5 m
- 12 V vehicle charging cable, 3.5 m
- Accessory bag
- Manual

Check contents Check the contents of the package for completeness and visible damage right after receipt. In the case of visible damage, the device must under no circumstances be taken into operation. If something is missing or damaged, please contact your local sales representative.

Optional accessories The following optional accessories can also be ordered from Megger Sales:

Accessory	Description	Item number
Connection set for HV cable terminations	Connection set with 8 larger connection clamps (e.g. for HV cable terminations) and connection cables 2 m in length (for the wiring at the far end of the cable)	1003344
External safety device	Safety device for norm-compliant signaling and Emergency Stop according to DIN EN 50191 / VDE 0104.	2010012
Connection cable VK 67	Connection cable for connection of the external safety device.	820003129

2.2 Technical Data

The HVB 10 has the following parameters:

Parameter	Value
Output voltage	0 ... 10 kV DC, bipolar
Output current	200 mA at 0.5 ... 1.5 kV, 60 mA at 5 kV, 30 mA at 10 kV
Maximum permitted capacity of the test object	25 µF
Test voltage	0 ... -10 kV
Prelocation <ul style="list-style-type: none"> • Method • Measuring accuracy 	Voltage drop method (fully automatic) ±0,1%
Pinpointing <ul style="list-style-type: none"> • Voltage • Duty cycle • Pulse rates 	0 ... -10 kV DC, pulsed selectable 0.5:1 / 1:2 / 1.5:0.5 / 1.5:3.5 4,8 Hz („vLoc“ A-frame of VivaxMetrotech) 3 Hz („SFL2“ A-frame of Metrotech)
Power supply (rated voltage)	88 V ... 264 V, 50 / 60 Hz
DC supply (for charging only)	12/24 V DC
Battery	Built-in NiMH battery (340 Wh)
Operating time whilst battery powered	approx. 2 hours ¹
Power consumption	max. 500 VA
Display	320 x 240 pixel LCD, LED backlight
Interfaces	USB port
Memory	2 GB flash memory for system and user data

¹ The value depends largely on the operating conditions. The value specified applies to continuous pinpointing with a rate of 1:3 at an output of 300 W.

Parameter	Value
Data logging	with a USB stick
Operating temperature	-25 °C ... +55 °C
Storage temperature	-40 °C ... +70 °C
Operating humidity	max. 93% relative humidity
Dimensions (W x H x D)	500 x 457 x 305 mm
Weight	25 kg
Protection class (according to IEC 61140 (DIN VDE 0140-1))	I (protective earthing)
Protection rating (according to IEC 60529 (DIN VDE 0470-1))	IP53 (with closed lid)

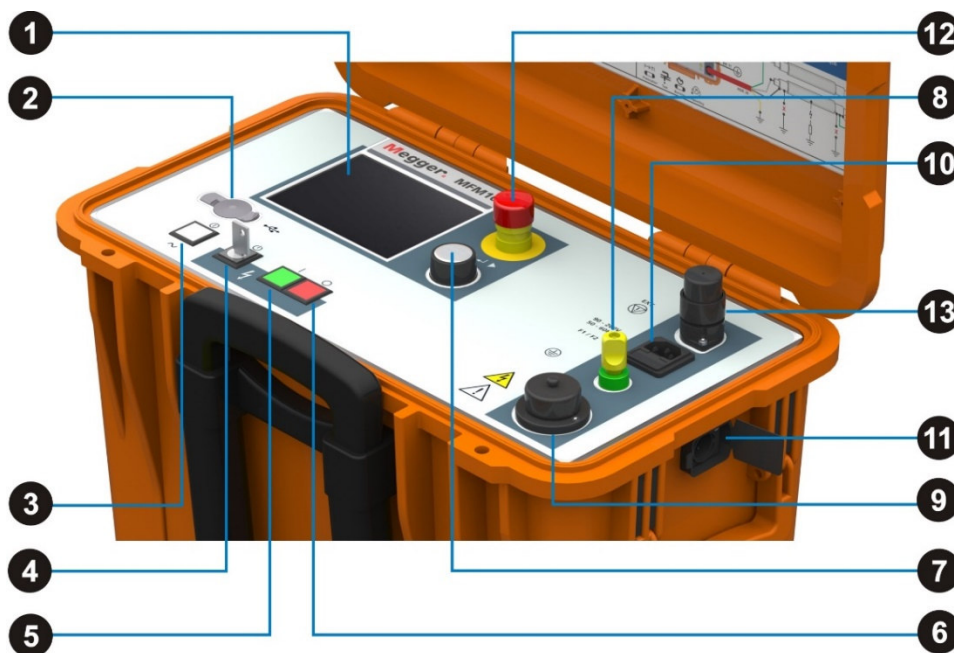

2.3 Connections, Controls and Display

The HVB 10 has the following connections, controls and display:



Element	Description
1	Touch-screen display
2	USB port
3	On/off push-button
4	HV "interlock" key switch
5	"HV ON" push-button
6	"HV OFF" push-button
7	Rotary encoder
8	Protective earthing connection
9	HV output
	<div style="border: 1px solid black; padding: 5px;">  <p>The HVB 10 generates a dangerous voltage of up to 10 kV during HV operation. This is induced into the HV connection cable through the HV output.</p> </div>
10	Power supply socket with fuses F1 / F2 (2 x M6.3/250)
11	12 ... 24 V DC charging socket
12	Emergency off button
13	Socket to connect the external safety device (see page 18)

3 Commissioning

 WARNING	<p>Safety instructions for commissioning</p> <ul style="list-style-type: none">• The safety guidelines for the operation of mobile testing systems often differ from one network operator to another and are frequently subject to national regulations (such as the German BGI 5191). Before the measurement session, find out what the applicable guidelines are and follow the rules set out therein precisely, in respect of the organisation of work and the commissioning of the mobile test system.• Before connecting the test object, always follow the general safety instructions and the five safety rules in particular (see page 8).• Select a location that is sufficient for the weight and size of the system and which ensures that it stands securely.• The air inlet and outlet vents on both sides of the device may not be covered during operation.• When setting up and connecting the device, make sure that it does not impair the function of any other systems or components. If other systems and components have to be modified in order to set up and operate the device, be sure to reverse these actions when the work is finished. Always take the special requirements of these systems and components into account and only carry out work on them after consulting and obtaining approval from whoever is in charge of them.• All cables which are out of operation and not tested must be shorted and earthed.• The protective earth connection  must always be connected to a suitable earthing point (e.g. station earth). Inadequate protective earth, especially when operating the HVB 10 by battery, can raise the potential of the device, and the hazardous voltages produced make it unsafe to handle.• Since the voltage applied to the test object can assume values that pose a risk of incidental contact, the cable ends must be shielded in accordance with VDE 0104 to avoid this. When doing so, be sure to take all cable branchings into account.
---	--

3.1 Electrical Connection in Fault Prelocation Mode

Connection diagram The following figure shows the simplified connection diagram:

88 V ... 264 V,
50 / 60 Hz

Connecting method for sheath fault location

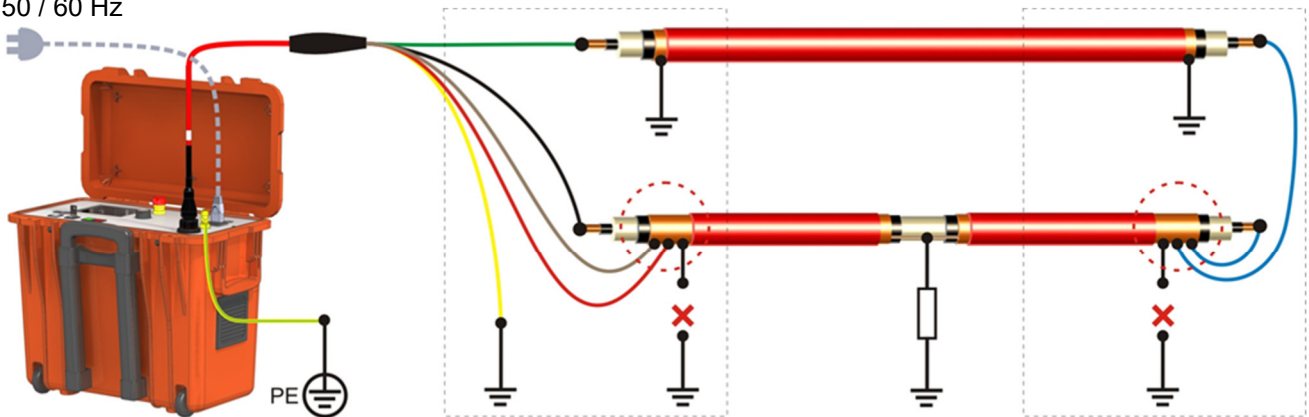

Connecting method for a fault between inner conductor and shield

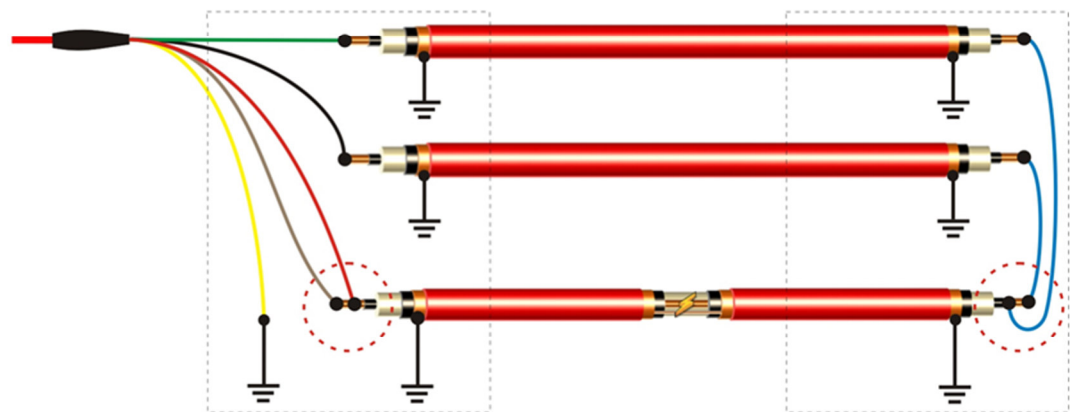



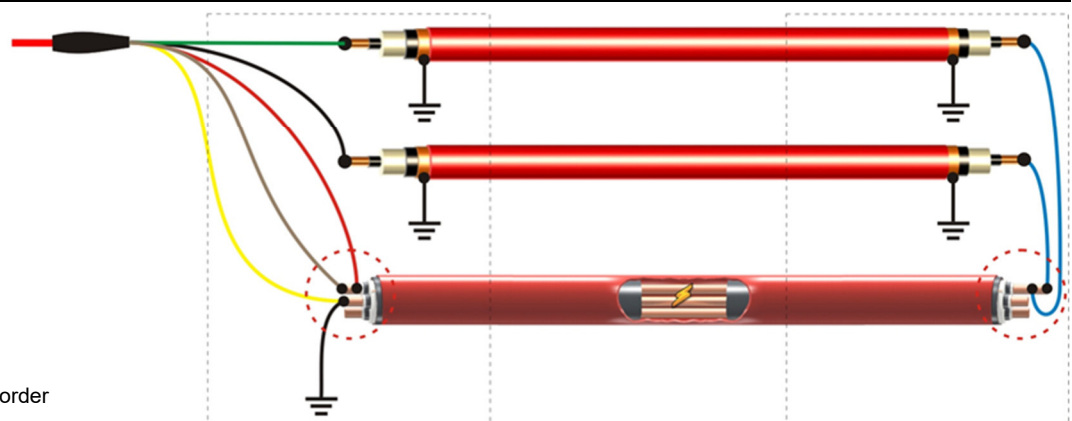



Connecting method for a fault between two adjacent conductors of a multicore cable



 Observe position / order

Procedure Connect the system in the following order:

Step	Description
1	Using the earthing cable, the protective earthing connection  of the HVB 10 is connected to a suitable point on the protective earth system (station earth).
2	<p>Plug in and tighten the HV connection cable to the HV output  on the device, in compliance with the alignment specified by the guide grooves.</p> <div style="border: 1px solid black; padding: 5px;">  <p>To protect the HV connector from damage, the protective caps on both jack and plug have to be reinstalled as soon as the cable is disconnected from the device.</p> </div>
3	Depending on the applied connecting method (see figure on previous page), connect the yellow connection lead either directly to a suitable earth point of the cable system under test or to one of the faulty inner conductors (which in turn needs to be earthed).
4	<p>Connect the red and the brown connection leads to the conductor to be tested (see figure on previous page).</p> <hr/> <div style="border: 1px solid black; padding: 5px;">  <p>To achieve optimal results during prelocation, you should use separate connection clamps or the supplied red Kelvin clip!</p> </div> <hr/>
5	Connect the black and the green connection leads to separate healthy conductors (auxiliary conductors) of the same cable system.
6	<p>At the far end of the cable, connect both auxiliary conductors to the conductor to be tested (the one to which the red and the brown connection leads are connected to).</p> <hr/> <div style="border: 1px solid black; padding: 5px;">  <p>To achieve optimal results during prelocation, you should use separate connection clamps or the supplied red Kelvin clip to connect the auxiliary conductors to the conductor under test.</p> <p>Make sure the contact is of good quality (remove or clean any dirt or corroded surfaces).</p> </div> <hr/>
7	<p>In case of a sheath test or a sheath fault location, the earthing of the shields and the auxiliary conductors must be removed!</p> <p>If there are any voltage transformers, they must be separated from the test object. Make also sure that there is no indirect contact to earth, e.g. through joints.</p>
8	<p>If the unit is to be powered through the mains, connect the supplied mains power cable to the power supply socket  of the HVB 10 and a mains socket.</p> <p>Otherwise, the device on being switched on is automatically powered by the internal battery. In which event, ensure that the battery has a sufficient charge. If necessary, charge the battery (see page 36).</p>

3.2 Electrical Connection in Testing, Burning and Pinpointing Mode

In testing, burning and pinpointing mode, all connecting leads except of the yellow one have to be connected to the conductor to be tested or faulty conductor respectively.

Inner conductor testing / inner conductor fault burning

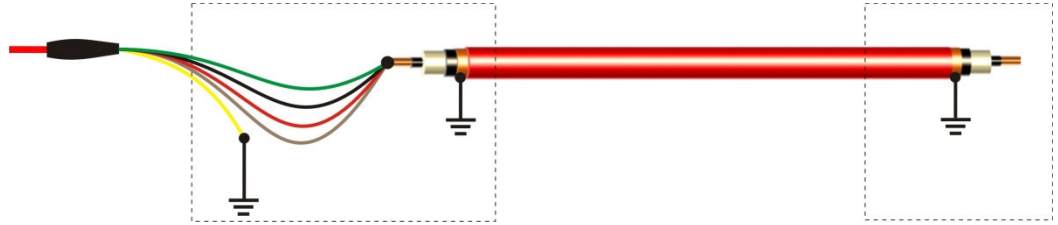

Sheath testing or sheath fault burning / pinpointing

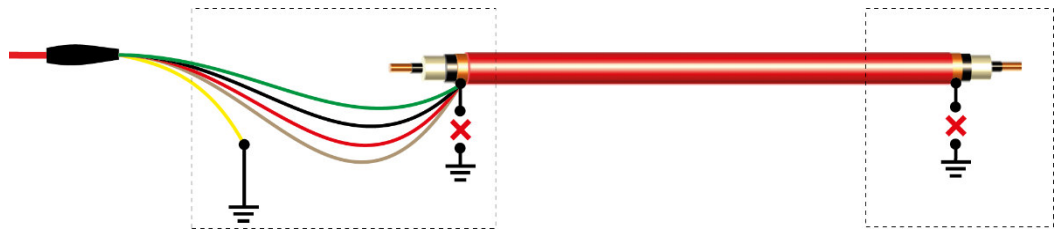

When testing cable systems for which the probability of a fault is very low, all conductors to be tested can be bridged and tested in a single step, without having to reconnect.

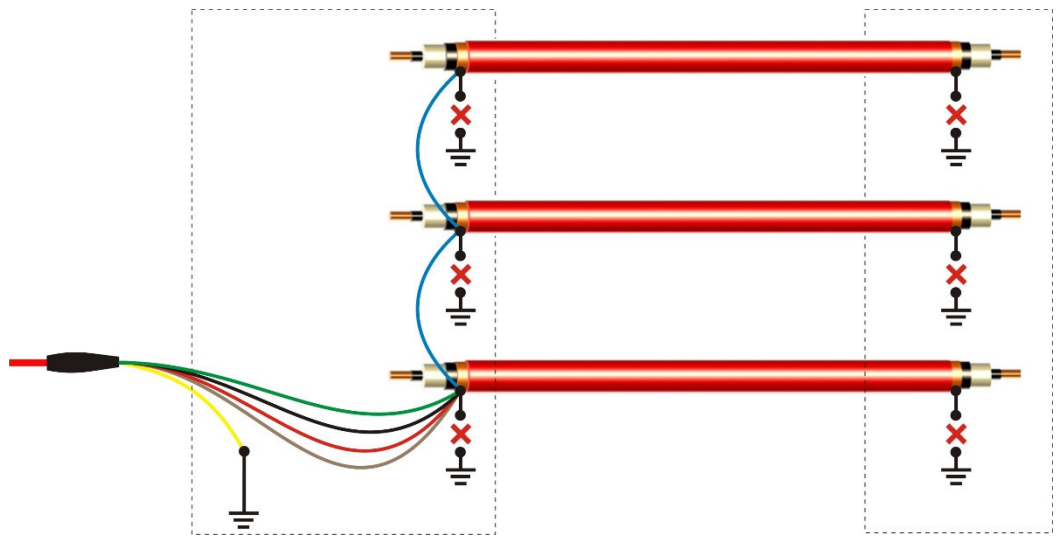

In this procedure, the capacity of the measured object is the sum of the capacities of all the connected conductors and, of course, must not exceed the maximum capacity of 25 μF ! If the test result indicates that one of the conductors is affected by leakage fault, the electrical connection must be corrected and each conductor individually tested.

3.3 Electrical Connection: Special Applications

Prelocation using one auxiliary conductor only This method of prelocating a fault should only be used when absolutely unavoidable, e.g. when no second, fault-free auxiliary conductor is available.

The precision will be impaired in the same way as the simple Murray loop bridge is impaired by the effects of the contact resistances, but should remain comparatively higher.

Furthermore, the auxiliary conductor must be fault-free. It is connected as follows:

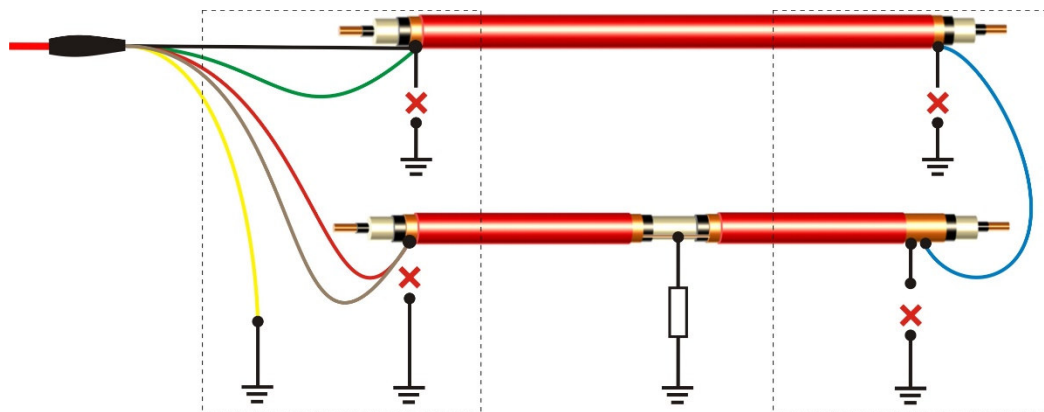

i For this type of prelocation, the **double cable length** must be entered!
 If both conductors are not of the same type (cross section, conductor material, length), they should be treated like a mixed cable with two sections (with the faulty conductor being the first section) during prelocation.

Prelocation when there is direct access to both ends of the cable

Under certain circumstances, prelocation can also be performed on a spooled cable which allows the HVB 10 to be connected directly to both ends of the cables.

To prelocate an inner conductor fault, the cables only have to be connected to the two faulty conductors as shown in the following illustration (shield/inner conductor or inner conductor/inner conductor):

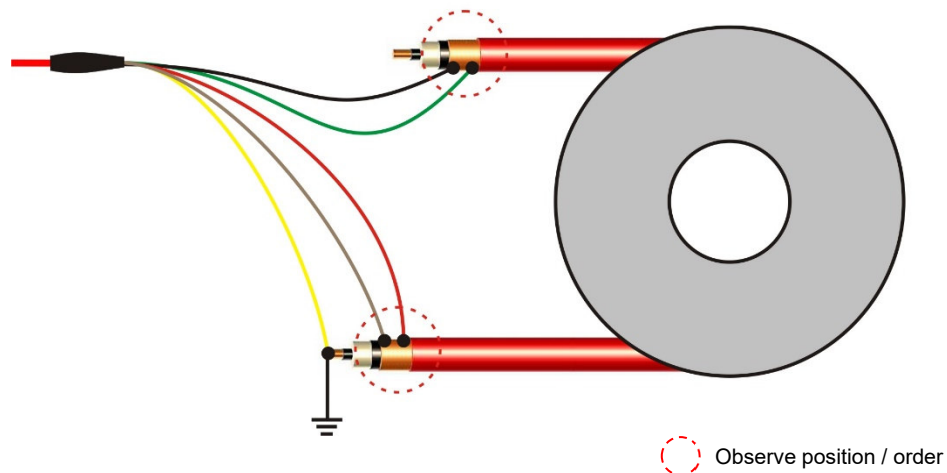

Prelocating a sheath fault, in contrast, requires a conductive sheath which is used as a return conductor for the fault current. The yellow connection cable must, in this case, be connected to the earthed outer sheath. The contact for the conductive sheath must be established very carefully (e.g. using copper mesh tape which is looped tightly around the sheath several times and pressed securely in place using pipe clamps or cable ties).



The reference point for the measured fault distance is the end of the cable to which the yellow line is connected.

Prelocation for cables with a conductive outer layer installed in pipes

For this application, the conductive outer sheath of the cable is used as a return path for the fault current. Accordingly, the outer sheath must be earthed at as many places as possible to ensure the fault current can flow out of the pipe and into the ground. An earth point like this can e.g. be established with the aid of copper mesh tape (see above).

3.4 Use of an External Safety Device (Optional)

Purpose With the aid of an external safety device, the current status of the system can be made clearly visible with coloured signal lamps and the generation of HV can be interrupted or locked with an EMERGENCY OFF switch and key switch (norm-compliant signalling and EMERGENCY OFF according to DIN EN 50191 / VDE 0104).

Connection The external safety device must be connected to the socket 13 that has been provided for this purpose.

In the event that no external safety device is used, the corresponding dummy plug must be screwed on to the socket.

Description The following figure shows the optional external safety device:



Part	Description
1	Green signal light Lights up when the system is switched on but is not in high voltage operation.
2	Red signal light Lights up as soon as high voltage can be generated. All discharge and earthing devices are open and the test object must be treated as live.
3	“HV interlock” key switch <div style="display: flex; align-items: center; margin-bottom: 5px;"> High voltage unlocked </div> <div style="display: flex; align-items: center; margin-bottom: 5px;"> High voltage locked </div> <p>In the locked state, the key can be removed and the system can thus be protected against unauthorised high-voltage operation.</p>
4	EMERGENCY OFF switch

4 Operation

4.1 Switching On the System

As soon as the device receives voltage through the power supply socket, ⑩ it automatically starts charging the battery. A corresponding message appears on the display.

The HVB 10 is started by pressing the on/off push-button ③. After a few seconds, the system is ready for use. The main menu appears in the display.

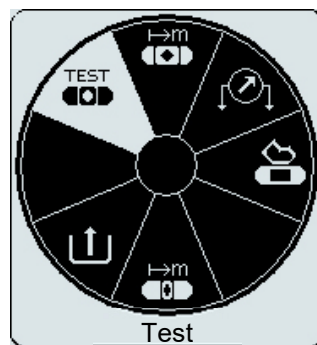

In this state, the high voltage source is still switched off and the high voltage output earthed via a discharge resistor.

4.2 General Operation

Navigation within the menus Navigation within the menus is accomplished almost entirely via the circular selection menu:

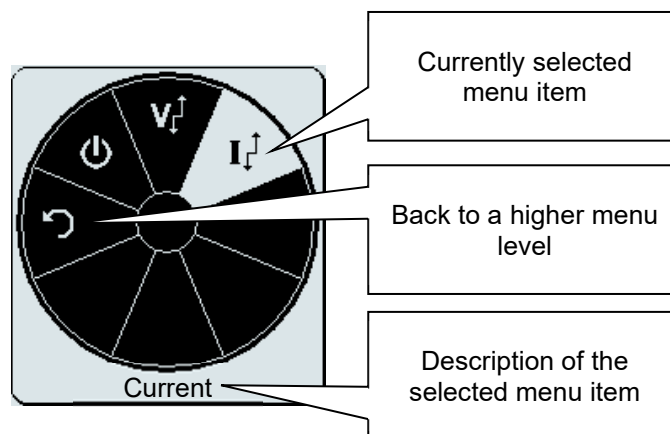

The operation of the system with the rotary encoder ⑦ is as follows:

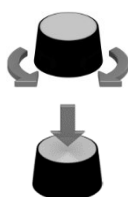

- Select a menu item
- Increase or decrease the value of a variable parameter
- Call up the selected menu item
- Confirm the settings made

Alternatively, almost all the steps can be accomplished directly on the touch screen.

Status bar The status bar at the bottom of the screen provides the following information:

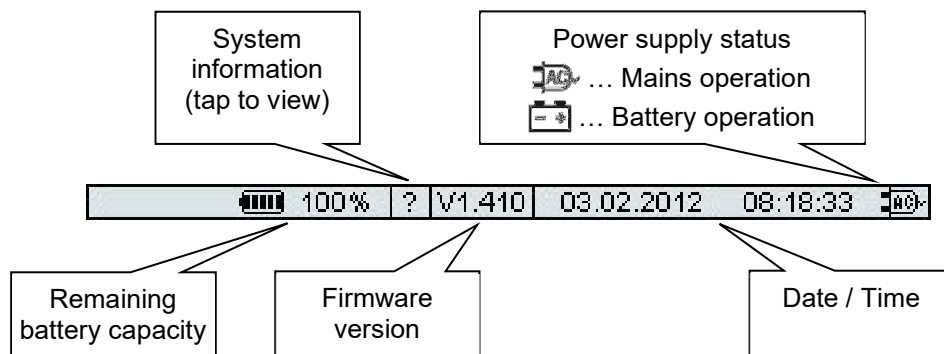

Adjusting the test or measuring parameters When setting a variable parameter, the following view appears:

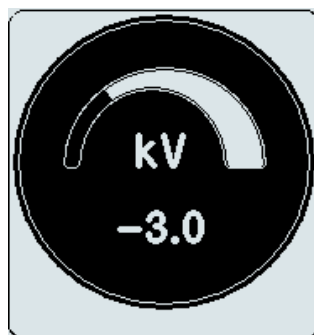

The value of the parameter can then be varied by turning the rotary encoder within the permissible range of values and pressing it briefly to confirm.



As the output voltage settings can be bipolar (depending on the operation mode), the voltage value always has a positive or negative prefix. To change the polarity, the voltage must first be reset to 0. The polarity can then be selected, by continuing to rotate the rotary encoder anticlockwise.

4.3 Security Mechanisms

Introduction The safety circuit of the system permanently tests all security-related parameters and switching operations on the system as soon as an operating mode is selected that activates the HV output. Should the safety circuit detect a deviation from the monitored conditions while in high voltage mode, high voltage is immediately switched off and the HV output is discharged. The fault that occurred is shown in the display and must be eliminated before operation can be resumed.

The safety circuit's conditions The following conditions must be fulfilled in order to perform tests under high voltage:

- The HV "interlock" key switch ④ must be in the ⏻ position.
- The EMERGENCY OFF switch ⑫ must not be pressed.
- F-Ohm: The transfer resistance between protective earth and operational earth must not exceed a certain threshold (possible fault sources: missing protective earth connection, poor earthing conditions or HV plugs that are not securely bolted).
- The HV connection cable must be correctly connected (see below).

Check of connections If activated in system settings (see page 25), an automatic connection check takes place upon activation of the test and prelocation operating modes. In order to get the mode started, the check must result in reasonable resistance values between the individual connections.

In the case of any deviations, the wiring diagram corresponding to the selected operating mode is displayed. The following figure shows the screen view after a failed connection check:

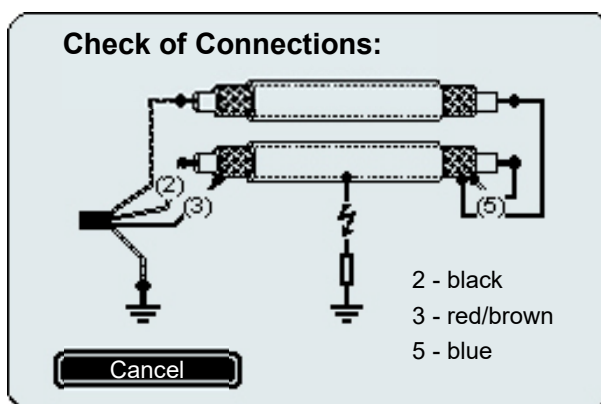

In this case, the system should be turned off and the connections should be checked and corrected.





i If the check keeps failing even after the connections have been verified and corrected, this may be due to the characteristics of the cable under test (e.g. very high capacity, low resistance cable faults or small cross section). In such a case, the function should be turned off in the system settings (see page 25).

4.4 System Settings

The setup menu which is divided into following categories can be accessed via the  menu item from the main menu:

Category	Setting	Description
General	Date / Time	Correct date and time settings are required for the logging function.
	Sprache	Selection of the interface language.
Test	Current Limit	Enables / disables the possibility to set a current limit in test operating mode.
	Test of connections	Enables / disables the automatic connection check (see previous page) in the test operating mode.
	Flash over detection	Enables / disables automatic flash-over detection with abrupt termination of the test.
Prelocation	EasyProt report	Enables / disables the logging function. If this function is active, a dialog box prompts you to store the logged data right after the sheath test has been finished. This requires a USB flash drive to be plugged into the USB port  .
	Test of connections	Enables / disables the automatic connection check (see previous page) in the prelocation operating mode.
Service		Access to this password protected area is restricted to authorized service personnel only.

Procedure Proceed as follows to perform insulation testing:

Step	Description
1	In the main menu, call up the menu item  .
2	Set voltage and test duration in accordance with the type of cable to be tested (see previous page).
3	Start the test via the menu item  .
4	Press the “HV ON” push-button  . Result: The test voltage is ramped up and the conductor under test charged. Sudden changes or just one single fast increase of the current during the voltage rise are a clear indication of an insulation fault and are logged by the system. During the further course, brief current increases are also continuously monitored. After a voltage flash-over (if activated in system settings (see page 25)) or the expiry of the test duration, the high voltage switches off automatically.
5	If the test is run in continuous operation mode, the high voltage must be manually deactivated with the “HV OFF” push-button  .
6	If this has been activated in the system settings (see page 25), a query will be issued at the end of the test whether the log should be saved. To do so, a USB flash drive must be inserted into the USB port  after which the Yes button must be pressed.

Evaluation of the test results Generally, the results of a insulation test can be divided into the following categories:

Test result	Description / action
The insulation passed the voltage test without any irregularity.	The insulataion is intact and within the scope of normal, regular cycles should continue being tested.
During the test increased leakage current values were detected	If the determined leakage current values are above the limits specified by the cable owner, the tested cable should be examined in more detail soon or at least a shorter testing cycle should be introduced.
There were one or more breakdowns in the insulation during the test.	If possible, the fault should immeadiately be prelocated (see page 28) and subsequently pinpointed.

4.5.2 Prelocating a Fault - /

Introduction In order to substantially reduce the time required for pinpointing, the pinpointing of the location of the fault is preceded by a prelocation. This reduces the risk of the fault location unintentionally “drying up” during the course of a lengthy pinpointing.

Due to thermo-electric or galvanic effects there can be offset voltages on top of the actual measured voltage during the measurement. To eliminate these effects, the prelocation is performed with bipolar voltages, i.e., the system automatically performs two measurements (one with positive and one with negative polarity).

The length of the cable must to be known for the fault prelocation!

Prelocation modes The HVB 10 offers the following two prelocation modes:



The **standard mode** () provides good results for typical sheath faults with fault resistances of up to some hundreds of kilohms and shield cross sections in the range of 25 to 50 mm².

The **high accuracy mode** () takes more time for the algorithm to complete, but will utilize the full potential of the measuring and control circuits of the instrument. Thus, it is ideally suited for prelocating difficult, high-resistive faults (e.g. in the inner insulation of PILC cables).

The instructions provided in this section apply for both modes!

Measuring parameters

In preparation of prelocation, the following parameters must be set:

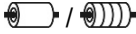
Menu item	Description
	<p>Voltage</p> <p>The device always carries out prelocation bipolar and fully automatically. The amount of the voltage can be set within the range of 0 kV to 10 kV. The voltage should be set to the value at which the fault occurred during the previous test.</p> <p>In the event that the prelocation is to be performed immediately after a test, the device software suggests an appropriate voltage value for the prelocation, which can be manually changed at any time.</p>
	<p>Cable length</p> <p>The length of the connected cable in metres.</p>
	<p>Cable sections / No cable sections</p> <p>Menu item to specify whether the cable under test has mixed sections (i.e. sections with different cross sections and / or conductor material) or the same cross section and conductor material along the entire cable length.</p> <p>When set to Cable sections, the HVB 10 will request the parameters for the cable sections at the end of the prelocation measurement. In that routine, only the section data that are needed for the calculation of the fault distance need to be entered, If, for example, a cable consists of 6 sections and the fault is located in section 3, only the data for section 1, 2 and 3 need to be entered before the HVB 10 provides the correct fault distance.</p>

Procedure Proceed as follows to perform fault prelocation:

Step	Description	
1	In the main menu, call up the menu item (standard accuracy mode) or (high accuracy mode) depending on the cable and fault characteristics.	
2	Set the voltage, the cable length and the type of cable (see previous page).	
3	Start the fault location via the menu item .	
4	Press the “HV ON” push-button . Result: The device runs through the automatic fault location algorithm. Readings are taken from the near and far ends of the cable, respectively, with both voltage polarities and the fault distance determined, using the voltage drop method.	
	<div style="border: 1px solid black; padding: 5px;"> If the “HV OFF” push-button is pressed during the automatic prelocation, operation may not be stopped and high voltage may not be turned off until the current sub-step is finished. Accordingly, in emergencies the emergency off button must always be used, as the high voltage is then immediately switched off and the cable discharged. </div>	
	On completion of the measurement, the high voltage is switched off and the cable discharged.	
5	If the cable under test has no mixed sections... The fault distance that has been determined can be read in the display.	If the cable under test has mixed sections... Enter length (in m), cross section (in mm ²) and conductor material (Al or Cu) of the first (nearest) section. If the measured resistance values do indicate that the fault position is beyond this section, the following sections have to be specified the same way one after another. The <<< and >>> buttons can be used to browse, check and correct the entered data. As soon as the entered section has been identified as the faulty section, the fault distance can be read in the display.

Multiple sheath faults Multiple sheath faults at the same cable can lead to measurement errors and false distance data as the displayed distance is an average of the individual fault distances.

However, there are signs which indicate multiple faults and consequently should be taken into consideration during pre-location. Highly scattered distance values at changing test voltages can potentially indicate the presence of multiple faults, as the faults probably have different ignition voltages.



At the same time, these different ignition voltages offer an approach which allows prelocation to be carried out even on sheaths with multiple faults. The most ignitable fault can be measured first by carefully increasing the test voltage. After it has been located and repaired, a further prelocation can be carried out.

4.5.3 Pinpointing a Sheath Fault -

Introduction During sheath fault pinpointing, the HVB 10 transmits direct current pulses at an adjustable rate into the shield affected by the earth fault.

With each coupled pulse, the current flowing into the ground forms voltage gradients in the area around the fault, the centre of which can be located precisely with the assistance of a sheath fault locator and its earth rods (step voltage method).

Measuring parameters In preparation of sheath fault pinpointing, the following parameters must be set:

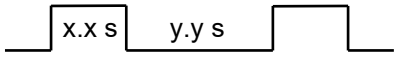
Menu item	Description
	<p>Voltage</p> <p>The voltage can be set within the range of 0 to –10 kV. The voltage should be set to a value providing sufficient current to pinpoint the fault. If multiple faults are likely, the voltage used during prelocation should be set to make sure only to ignite the prelocated fault.</p>
	<p>Current</p> <p>To prevent further damage to the cable sheath during the time-consuming pinpointing procedure or to limit the step voltage arising around the fault position, the current can be limited.</p>
	<p>Duty cycle</p> <p>Relationship between the duration of the direct current pulse and the interval between two pulses. You can choose from the following options:</p> <p>x.x s – y.y s </p> <p>A-vLoc Special pulse rate (3 Hz) for the “vLoc” A-frame of VivaxMetrotech.</p> <p>A-SFL2 / Dx Special pulse rate (4.8 Hz) for the “SFL2” A-frame of Metrotech.</p>

Procedure Proceed as follows to perform sheath fault pinpointing:



Step	Description
1	In the main menu, call up the menu item .
2	Set the voltage, the current and the duty cycle.
3	Start the pinpointing via the menu item .
4	Press the “HV ON” push-button .
	Result: The HVB 10 with the set pulsing couples the DC pulse in the shield affected by the earth fault.
5	Locate the fault location with the assistance of a suitable receiver (e.g. ESG, A-frame).
	<div style="border: 1px solid black; padding: 5px;"> For detailed instructions on how to use the receiver, please read the respective manual. </div>
	<div style="border: 1px solid black; padding: 5px;"> <div style="display: flex; align-items: center;"> <div> <p>WARNING</p> <ul style="list-style-type: none"> Do not leave the system in operation unattended and accessible to the third parties. Lock the location securely or instruct an authorised person to monitor the system. Due to the current emerging into the ground at the fault location, a step potential is produced. Depending on the current rating and the respective ground and weather conditions, this voltage can exhibit different values near the fault location. When pinpointing with the aid of a earth leakage detector, close attention must be paid to the respective voltages measured in order to detect dangerous voltages in time. In such an event, the current rating on the HVB 10 must be reduced accordingly. </div> </div> </div>
6	After completing the pinpointing of the sheath fault, press the “HV OFF” push-button to switch off the pulsed DC.

4.5.4 Burning -







Introduction This mode allows manual control of the output voltage during HV operation.

Due to the high thermal stress which goes along with the burning process, the burn duration is limited to 5 minutes.

Measuring parameters In preparation of the burning process, the following parameters must be set:

Menu item	Description
	Voltage The voltage can be set bipolar (see page 23) within the range of –10 kV to +10 kV. The voltage value of the previous test should be used.
	Current To prevent damage to the cable sheath, the current can be limited.

Procedure Proceed as follows to operate the device in burning mode:

Step	Description
1	In the main menu, call up the menu item  .
2	Set the voltage and the current.
3	Start the test via the menu item  .
4	Press the “HV ON” push-button  . Result: The test voltage is ramped up and the cable shield charged. The respective voltage applied and the current passing through are shown in the display. Via the  menu item, the output voltage can be changed during burning which makes it possible to observe the response of the fault in real-time.
<div style="border: 1px solid black; padding: 5px;">  To avoid interruption of the burning process, polarity should not be changed during burning. </div>	
5	Terminate the burning process by pressing the “HV OFF” push-button  . The burning process will stop automatically after 5 minutes, if by this time it hasn't been stopped manually.
<div style="display: flex; align-items: center;">  <div> <p>CAUTION</p> <p>Between two time-consuming burning operations the unit needs to cool down for a few minutes!</p> </div> </div>	
6	Afterwards, try to prelocate (see page 28) the sheath fault again.

4.6 Concluding the Test

Once the measurement has been completed, the system can be switched off with the on/off push-button .

The test object is to be earthed and short-circuited as well as checked that it has been completely discharged (e.g. using a properly sized discharge rod).

Afterwards, the HVB 10 can be disconnected from the test object.

 WARNING	<ul style="list-style-type: none"> • Follow the five safety rules (see page 8). • Even if proper disconnection and automatic discharging via the internal discharging device has taken place, system components that have been under voltage should only be touched once they have been discharged using an adequate discharging rod and visibly earthed and shorted. • Only undo the earthing and short circuiting measures when the test object is to be operated again.
---	---

 CAUTION	<p>To protect the HV connector from damage, the protective caps on both jack and plug have to be reinstalled as soon as the cable is disconnected from the device.</p>
---	--

5 Processing Log Data

When log data are exported after a test is complete, the files are written to the *\Prot* directory on the USB flash drive.

The name of the file is comprised of the current date and a serial number. For larger test series, making notes about the sequence of the tests is recommended to make classify them easier later on.

The lean logging software MeggerBook Lite which is suitable for viewing, printing and archiving the logs.



For more detailed information on using the software, please read the integrated Online help.

6 Updating the Firmware

Proceed as follows to update the firmware:

Step	Description
1	Register as a user on the Megger homepage and download the latest firmware version from the user area.
2	Save the <i>HVB10_<Version>.exe</i> file to the root directory of an empty USB flash drive.
3	<p>Execute the file and confirm the following message with OK.</p> <p>Result: The directory structure of the USB flash drive should then look as follows:</p> <div style="text-align: center;"> <p>USB drive + DISPLAY + FIRMWARE LOCAL</p> </div>
4	Plug the USB flash drive into the USB port of the HVB 10 which has to be switched off .
5	Briefly de-energize the HVB 10 by pulling the power cord. Afterwards, reconnect the power cord and power on the unit.
6	<p>The boot process is interrupted by a message which has to be confirmed with YES (by touching the button on the screen).</p> <p>Result: The new firmware is installed.</p>

 Installation of the new firmware may take a few minutes and requires several automatic restarts. Do not unplug the flash drive or power off the system during the whole installation process! After the installation is done, the HVB 10 performs one last automatic restart, whereupon the main menu is displayed.

7 Maintenance and Care

Maintenance It is not necessary to open the housing of the device to commission and operate the system. Opening the housing causes the immediate termination of all warranty claims!



The connections and connection leads of the system must be regularly tested to ensure that they are free of defects and intact, in accordance with the applicable national and company-specific arrangements.

Restrictions on mandatory device tests (e.g. in accordance with VDE 0701-0702) It may be necessary to measure the insulation resistance in order to demonstrate the effectiveness of basic protective measures after a repair or as part of a repeat test (in accordance with VDE 0701-0702 or a comparable standard). This must be performed at a reduced measurement voltage of 250 VDC, as the overvoltage protection devices installed in the power input could trigger at higher measurement voltages and compromise the results of the test. A 250 VDC test is considered as passed if the measured insulation resistance is greater than 1 MΩ.

Storage If the device is not used for a lengthy period, it should be stored in a dust-free and dry environment. Continuous moisture (humidity) especially when combined with dust can reduce critical insulating clearances that are essential for safe high-voltage operation.

Store the unit always at a full state-of-charge. Apply topping charge every six months.

Charge The internal battery can be recharged in two ways:

- Through the mains connection lead, which connects the power supply socket  to an appropriate mains socket
- Through the motor vehicle charging cable, which connects the charging socket  with the 12 V DC on-board voltage of a motor vehicle

As soon as one of these connections is made, the display is activated and the progress of the charging process is shown. It takes about 4 to 6 hours to charge the battery completely.



As soon as the device is switched on, the charging process is interrupted, i.e. charging is not possible whilst it is in operation!

Fuse Replacement If the device cannot be switched on when the power supply is connected, the two fuses which are located next to the power socket  should be checked. The fuse holder must be pulled out.

If broken, the fuses should be replaced with appropriate type M6.3/250 micro-fuses (5 x 20 mm).



Tento symbol indikuje, že výrobek nesoucí takovéto označení nelze likvidovat společně s běžným domovním odpadem. Jelikož se jedná o produkt obchodovaný mezi podnikatelskými subjekty (B2B), nelze jej likvidovat ani ve veřejných sběrných dvorech. Pokud se potřebujete tohoto výrobku zbavit, obraťte se na organizaci specializující se na likvidaci starých elektrických spotřebičů v blízkosti svého působiště.



Dit symbool duidt aan dat het product met dit symbool niet verwijderd mag worden als gewoon huishoudelijk afval. Dit is een product voor industrieel gebruik, wat betekent dat het ook niet afgeleverd mag worden aan afvalcentra voor huishoudelijk afval. Als u dit product wilt verwijderen, gelieve dit op de juiste manier te doen en het naar een nabij gelegen organisatie te brengen gespecialiseerd in de verwijdering van oud elektrisch materiaal.



This symbol indicates that the product which is marked in this way should not be disposed of as normal household waste. As it is a B2B product, it may also not be disposed of at civic disposal centres. If you wish to dispose of this product, please do so properly by taking it to an organisation specialising in the disposal of old electrical equipment near you.



Този знак означава, че продуктът, обозначен по този начин, не трябва да се изхвърля като битов отпадък. Тъй като е B2B продукт, не бива да се изхвърля и в градски пунктове за отпадъци. Ако желаете да извърлите продукта, го занесете в пункт, специализиран в изхвърлянето на старо електрическо оборудване.



Dette symbol viser, at det produkt, der er markeret på denne måde, ikke må kasseres som almindeligt husholdningsaffald. Eftersom det er et B2B produkt, må det heller ikke bortskaffes på offentlige genbrugsstationer. Skal dette produkt kasseres, skal det gøres ordentligt ved at bringe det til en nærliggende organisation, der er specialiseret i at bortskaffe gammelt el-udstyr.



Sellise sümboliga tähistatud toodet ei tohi käidelda tavalise olmejäätmena. Kuna tegemist on B2B-klassi kuuluva tootega, siis ei tohi seda viia kohalikku jäätmeäitluspunkti. Kui soovite selle toote ära visata, siis viige see lähimasse vanade elektriseadmete käitlemisele spetsialiseerunud ettevõttesse.



Tällä merkinnällä ilmoitetaan, että kyseisellä merkinnällä varustettua tuotetta ei saa hävittää tavallisen kotitalousjätteen seassa. Koska kyseessä on yritysten välisen kaupan tuote, sitä ei saa myöskään viedä kuluttajien käyttöön tarkoitettuihin keräyspisteisiin. Jos haluatte hävittää tämän tuotteen, ottakaa yhteys lähimpään vanhojen sähkölaitteiden hävittämiseen erikoistuneeseen organisaatioon.



Ce symbole indique que le produit sur lequel il figure ne peut pas être éliminé comme un déchet ménager ordinaire. Comme il s'agit d'un produit B2B, il ne peut pas non plus être déposé dans une déchetterie municipale. Pour éliminer ce produit, amenez-le à l'organisation spécialisée dans l'élimination d'anciens équipements électriques la plus proche de chez vous.



Cuireann an siombail seo in iúl nár cheart an táirgeadh atá marcáilte sa tsli seo a dhiúscairt sa chóras fuóil teaghlaigh. Os rud é gur táirgeadh ghnó le gnó (B2B) é, ní féidir é a dhiúscairt ach oiread in ionaid dhiúscairthe phobail. Más mian leat an táirgeadh seo a dhiúscairt, déan é a thógáil ag eagraíocht gar duit a sainfheidhmíonn i ndiúscairt seanfhearas leictrigh.



Dieses Symbol zeigt an, dass das damit gekennzeichnete Produkt nicht als normaler Haushaltsabfall entsorgt werden soll. Da es sich um ein B2B-Gerät handelt, darf es auch nicht bei kommunalen Wertstoffhöfen abgegeben werden. Wenn Sie dieses Gerät entsorgen möchten, bringen Sie es bitte sachgemäß zu einem Entsorger für Elektroaltgeräte in Ihrer Nähe.



Αυτό το σύμβολο υποδεικνύει ότι το προϊόν που φέρει τη σήμανση αυτή δεν πρέπει να απορρίπτεται μαζί με τα οικιακά απόρριμματα. Καθώς πρόκειται για προϊόν B2B, δεν πρέπει να απορρίπτεται σε δημοτικά σημεία απόρριψης. Εάν θέλετε να απορρίψετε το προϊόν αυτό, παρακαλούμε όπως να το παραδώσετε σε μία υπηρεσία συλλογής ηλεκτρικού εξοπλισμού της περιοχής σας.



Ez a jelzés azt jelenti, hogy az ilyen jelzéssel ellátott terméket tilos a háztartási hulladékokkal együtt kidobni. Mivel ez vállalati felhasználású termék, tilos a lakosság számára fenntartott hulladékgyűjtőbe dobni. Ha a terméket ki szeretné dobni, akkor vigye azt el a lakóhelyéhez közel működő, elhasznált elektromos berendezések begyűjtésével foglalkozó hulladékezelő központhoz.



Questo simbolo indica che il prodotto non deve essere smaltito come un normale rifiuto domestico. In quanto prodotto B2B, può anche non essere smaltito in centri di smaltimento cittadino. Se si desidera smaltire il prodotto, consegnarlo a un organismo specializzato in smaltimento di apparecchiature elettriche vecchie.



Šī zīme norāda, ka izstrādājumu, uz kura tā atrodas, nedrīkst izmest kopā ar parastiem mājstaimniecības atkritumiem. Tā kā tas ir izstrādājums, ko cits citam pārdod un lieto tikai uzņēmumi, tad to nedrīkst arī izmest atkritumos tādās izgāztuvēs un atkritumu savāktuvēs, kas paredzētas vietējiem iedzīvotājiem. Ja būs vajadzīgs šo izstrādājumu izmest atkritumos, tad rīkojieties pēc noteikumiem un nogādājiet to tuvākajā vietā, kur īpaši nodarbojas ar vecu elektrisku ierīču savākšanu.



Šis simbolis rodo, kad juo paženklinto gaminio negalima išmesti kaip paprastų buitinių atliekų. Kadangi tai B2B (verslas verslui) produktas, jo negalima atiduoti ir buitinių atliekų tvarkymo įmonėms. Jei norite išmesti šį gaminį, atlikite tai tinkamai, atiduodami jį arti jūsų esančiai specializuotai senos elektrinės įrangos utilizavimo organizacijai.



Dan is-simbolu jindika li l-prodott li huwa mmarkat b'dan il-mod m'ghandux jintrema bħal skart normali tad-djar. Minhabba li huwa prodott B2B , ma jistax jintrema wkoll f'centri civici għar-rimi ta' l-iskart. Jekk tkun tixtieq tarmi dan il-prodott, jekk joghħbok għamel dan kif suppost billi tiehdu għand organizzazzjoni fil-qrib li tispējalizza fir-rimi ta' tagħmir qadim ta' l-eletriku.



Dette symbolet indikerer at produktet som er merket på denne måten ikke skal kastes som vanlig husholdningsavfall. Siden dette er et bedriftsprodukt, kan det heller ikke kastes ved en vanlig miljøstasjon. Hvis du ønsker å kaste dette produktet, er den riktige måten å gi det til en organisasjon i nærheten som spesialiserer seg på kassering av gammelt elektrisk utstyr.



Ten symbol oznacza, że produktu nim opatrzonego nie należy usuwać z typowymi odpadami z gospodarstwa domowego. Jest to produkt typu B2B, nie należy go więc przekazywać na komunalne składowiska odpadów. Aby we właściwy sposób usunąć ten produkt, należy przekazać go do najbliższej placówki specjalizującej się w usuwaniu starych urządzeń elektrycznych.



Este símbolo indica que o produto com esta marcação não deve ser deixado fora juntamente com o lixo doméstico normal. Como se trata de um produto B2B, também não pode ser deixado fora em centros cívicos de recolha de lixo. Se quiser desfazer-se deste produto, faça-o correctamente entregando-o a uma organização especializada na eliminação de equipamento eléctrico antigo, próxima de si.



Acest simbol indică faptul că produsul marcat în acest fel nu trebuie aruncat ca și un gnuoi menajer obișnuit. Deoarece acesta este un produs B2B, el nu trebuie aruncat nici la centrele de colectare urbane. Dacă vreți să aruncați acest produs, vă rugăm s-o faceți într-un mod adecvat, ducând-ul la cea mai apropiată firmă specializată în colectarea echipamentelor electrice uzate.



Tento symbol znamená, že takto označený výrobek sa nesmie likvidovať ako bežný komunálny odpad. Keďže sa jedná o výrobok triedy B2B, nesmie sa likvidovať ani na mestských skládkach odpadu. Ak chcete tento výrobok likvidovať, odneste ho do najbližšej organizácie, ktorá sa špecializuje na likvidáciu starých elektrických zariadení.



Ta simbol pomeni, da izdelka, ki je z njim označen, ne smete zavreči kot običajne gospodinske odpadke. Ker je to izdelek, namenjen za druge proizvajalce, ga ni dovoljeno odlagati v centrih za civilno odlaganje odpadkov. Če želite izdelek zavreči, prosimo, da to storite v skladu s predpisi, tako da ga odpeljete v bližnjo organizacijo, ki je specializirana za odlaganje stare električne opreme.



Este símbolo indica que el producto así señalizado no debe desecharse como los residuos domésticos normales. Dado que es un producto de consumo profesional, tampoco debe llevarse a centros de recogida selectiva municipales. Si desea desechar este producto, hágalo debidamente acudiendo a una organización de su zona que esté especializada en el tratamiento de residuos de aparatos eléctricos usados.



Den här symbolen indikerar att produkten inte får blandas med normalt hushållsavfall då den är förbrukad. Eftersom produkten är en så kallad B2B-produkt är den inte avsedd för privata konsumenter, den får således inte avfallshanteras på allmänna miljö- eller återvinningsstationer då den är förbrukad. Om ni vill avfallshanterera den här produkten på rätt sätt, ska ni lämna den till myndighet eller företag, specialiserad på avfallshantering av förbrukad elektrisk utrustning i ert närområde.