

Cable sheath testing and fault location system shirla



Copyright © 2009
All rights reserved.

Reproduction, circulation in any form whatsoever, publishing on online services or Internet, as well as duplication on data carriers, even in extracts or with changed format is allowed only with prior written permission of BAUR Prüf- und Messtechnik GmbH, A-6832 Sulz / Austria.

In the interest of our customers, we reserve the right to make changes in consequence of technical development. Therefore, figures, descriptions and delivery items are not binding.

Specified product and company names are trademarks or trade names of the corresponding companies.

Table of contents

1	General	3
1.1	Preamble.....	3
2	Use	4
2.1	Cable and cable sheath testing	4
2.2	Cable and cable sheath fault prelocation	4
2.3	Cable and cable sheath fault pin-pointing	5
3	Features	6
3.1	Safety features.....	6
3.2	Operating modes	6
4	Measurement principle and accuracy	7
4.1	Principle of the Wheatstone circuit	7
4.2	Bridge measurement in accordance with Glaser	9
4.2.1	With two auxiliary lines and constant line cross-section.....	9
4.3	Bridge measurement in accordance with Murray	11
4.3.1	With two auxiliary lines and non-constant core cross-section or different specific resistances of the line material	11
4.3.2	With one auxiliary lines and constant core cross-section	13
4.3.3	With one auxiliary line and different core cross-sections	13
4.4	Fault location on a cable with branch joint.....	14
4.4.1	Example	17
4.4.2	Unknown distance to branch joint.....	18
4.5	Measuring error.....	19
4.6	Comparison of the voltage drop method and bridge measurement	20
4.6.1	Plastic cable N2XSY with a copper screen	20
4.6.2	Shielded low voltage cable with a large cross-section	21
5	Operating controls	22
5.1	Operating unit	22
5.2	Connecting the ground line.....	23
5.3	Operating the menu	23
5.4	Voltage and current display	23
6	Commissioning	24
6.1	Important basic rules	24
6.1.1	Discharging and earthing.....	24

6.2	Preparing the device for cable or cable sheath testing.....	25
6.2.1	Preparing the cable.....	25
6.2.2	Connecting the protective ground cable.....	26
6.2.3	Connecting the high voltage feed cable for testing.....	26
6.2.4	Connecting to various cable types.....	26
6.3	Connections for bridge measurement.....	27
6.4	Using the menu.....	29
6.5	Switching high voltage on and off.....	30
7	Cable and cable sheath testing.....	32
7.1	Settings.....	33
7.2	Carrying out the tests.....	34
7.3	Ending a test early.....	35
8	Fault prelocation / measuring bridge.....	36
8.1	Settings.....	36
8.2	Sections.....	37
8.2.1	Working with only one section.....	38
8.2.2	Adding sections.....	38
8.3	Zero balancing.....	39
8.4	Repeating measurements.....	41
8.5	Ending measurement early.....	41
9	Fault pin-pointing.....	42
9.1	Connections and settings.....	42
9.2	Ending measurement early.....	44
10	Updating software.....	45
11	Technical data.....	46
12	Maintenance.....	47
12.1	Service personnel.....	47
12.2	Error messages.....	48
12.3	Error codes.....	48
12.4	Cleaning.....	50
13	Delivery includes.....	51
13.1	Replacement parts.....	51
14	Declaration of conformity.....	52
15	Index.....	53

1 GENERAL



Preamble.....	3
---------------	---

1.1 Preamble

This user manual contains important information on the proper use of the described product. Please read this user manual carefully before using the BAUR devices or systems.

In case of queries, please contact BAUR Prüf- und Messtechnik GmbH or the BAUR representative.

2 USE



Cable and cable sheath testing	4
Cable and cable sheath fault prelocation	4
Cable and cable sheath fault pin-pointing	5

BAUR Cable sheath testing and fault location system shirla is used for cable and cable sheath testing and for prelocating and pin-pointing cable faults. The intactness of insulation can be tested up to a DC test voltage of -10 kV.

In addition shirla provides the ideal solution for prelocating faults in unshielded cables and cable sheaths. The system uses the measuring bridge principle in accordance with Murray and Glaser.

To provide precise fault location shirla is used as a voltage source with a DC pulse pattern. The high voltage pulse is discharged into the ground at the location of the fault. The voltage funnel on the surface caused by this can be picked up using the step voltage method, enabling the location of the fault to be accurately determined.

2.1 Cable and cable sheath testing

shirla allows the user to carry out voltage tests at a test voltage of up to 10 kV on low voltage cables and cable sheaths. The measurements taken include current, voltage and fault resistance.

Cable sheath testing is carried out in order to detect damage to cable sheaths. To do this a DC test is carried out in accordance with the applicable standard. The duration of the test should comply with local regulations and can be preset in the device.



German standard DIN VDE 0276-620 makes test recommendations based on the cable length.

2.2 Cable and cable sheath fault prelocation

shirla has an integrated measuring bridge, which allows it to prelocate insulation faults in plastic insulated cable sheaths and earth faults (even high ohmic) in unshielded plastic low voltage cables with the highest precision.

The integrated measuring bridge was designed with this particularly in mind. The distance to the fault can be read directly in metres or as a percentage of the total cable length. For cables in a number of different sections, all the sections can be allowed for in terms of cross section and material. Different cross sections and materials have proportional effects on the distance to the fault and therefore can be taken into account.

In contrast to the voltage drop method, bridge measurement offers the advantage of a higher accuracy of measurement. With the aid of the internal high voltage source (up to 10 kV), the

device can also measure very high ohmic faults. Bridge measurements are carried out in accordance with Murray and Glaser (see *Measurement principle and accuracy* (on page 7)).

2.3 Cable and cable sheath fault pin-pointing

Cable and cable sheath fault pin-pointing is based on the principle of the step voltage method. To do this a cyclical voltage is applied to the cable or cable sheath in accordance with the diagram below. The pulsed voltage can be set at values up to 10 kV. With the step voltage meter (UL or KMF1), the device can locate damage to the cable sheath with the voltage funnel created.

Various patterns can be used to ensure reliable identification of cable or cable sheath faults. The following pulse patterns are available: (see *Fault pin-pointing* (on page 42)).

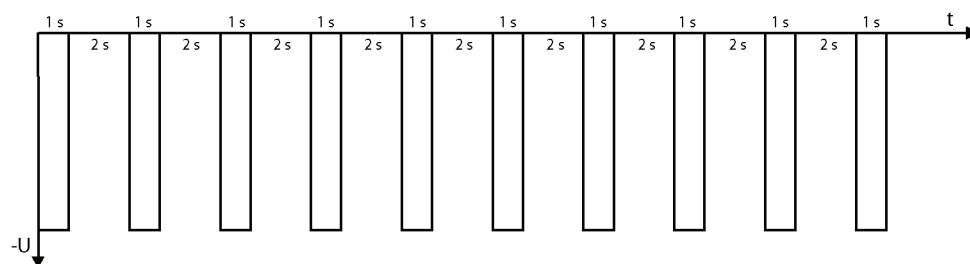
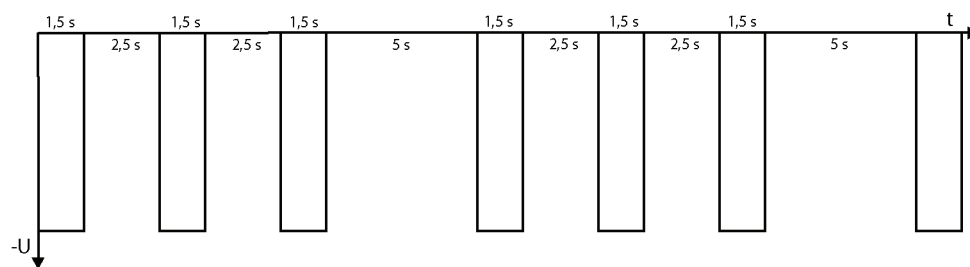
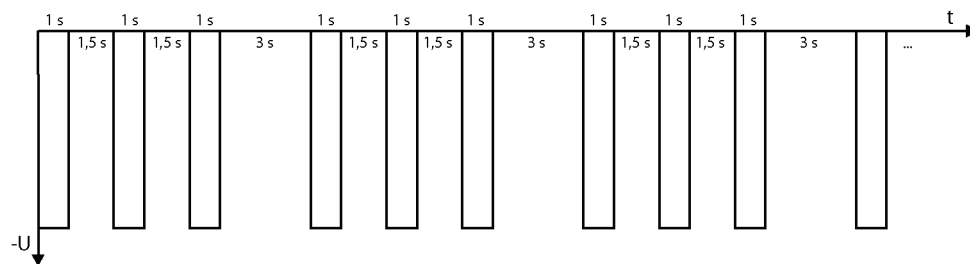

3 FEATURES



Safety features	6
Operating modes	6

An important advantage of the device is its portability, especially when used on site. The compact design and integrated rechargeable battery mean that the device is also very suitable for use on site. Working in bad weather is not a problem as the equipment is completely protected against splash water. A graphics display with a menu for all control functions ensures ease and simplicity of operation. The results of the tests and fault prelocation can be simply read from the USB stick.

3.1 Safety features

- Constructed in accordance with VDE DIN 0104, EN 50191
- Switch-on interlock for high voltage
- Emergency-off switch
- Status display of all important safety functions

3.2 Operating modes

- DC testing up to 10 kV
- Fault prelocation in accordance with Murray and Glaser
- Fault pin-pointing in accordance with step voltage method

4 MEASUREMENT PRINCIPLE AND ACCURACY



Principle of the Wheatstone circuit	7
Bridge measurement in accordance with Glaser	9
Bridge measurement in accordance with Murray	11
Fault location on a cable with branch joint.....	14
Measuring error.....	19
Comparison of the voltage drop method and bridge measurement.....	20

All bridge measurement methods that work with direct current for locating faults in cables in principle are based on modified Wheatstone circuits.

4.1 Principle of the Wheatstone circuit

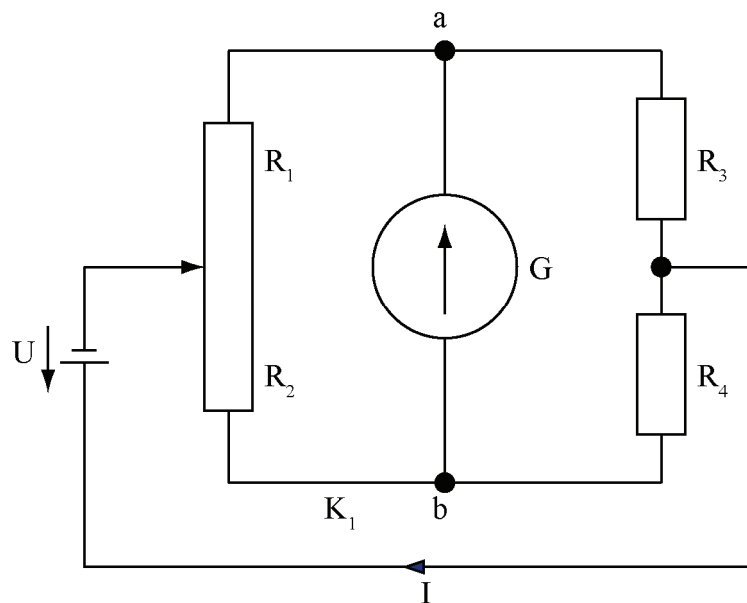

The bridge is balanced when points a and b are subject to the same potential. In this situation, the galvanometer shows zero.

Points a and b are at the same potential when the following condition is fulfilled:

$$\frac{R_1}{R_3} = \frac{R_2}{R_4} \quad \text{resp.} \quad R_4 = \frac{R_2}{R_1} * R_3$$

If R_x is the resistance R_x being sought, R_x can be defined as:

$$R_x = \frac{R_2 * R_3}{R_1}$$

When carrying out bridge measurement in accordance with Murray, the cable loop R_s forms the resistances R_3 and R_4 .

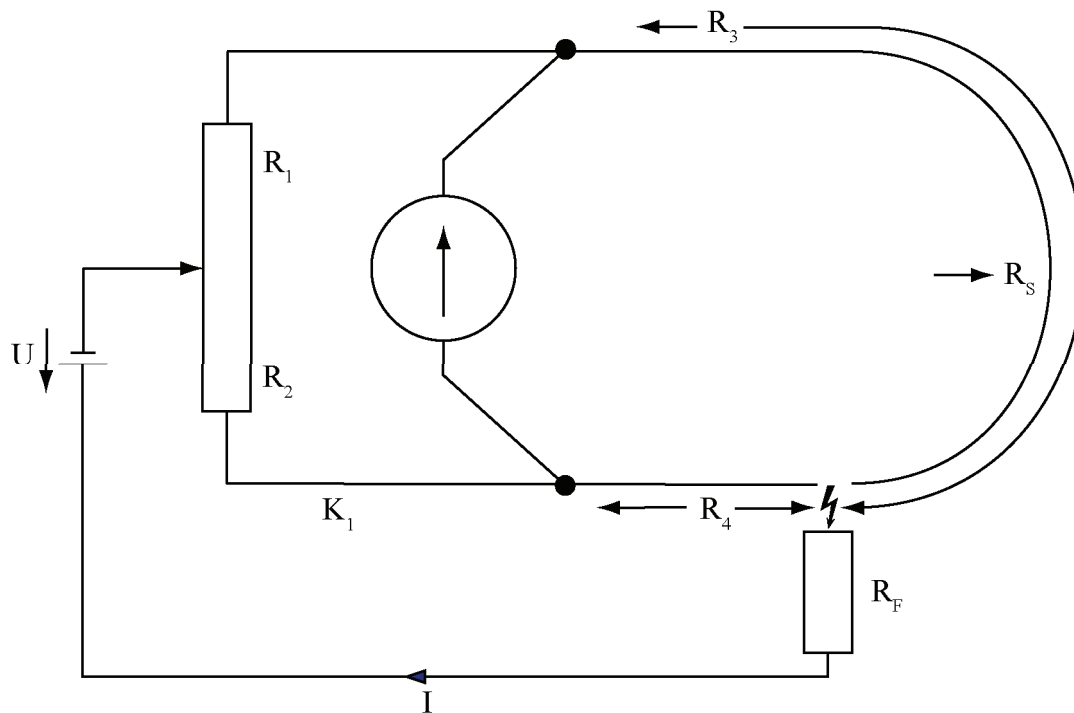

The degree of precision of the bridge depends on these factors:

- the bridge current I
- the loop resistance R_s of the cable loop
- the power adjustment of the internal impedance of the galvanometer to the bridge resistances
- the sensitivity of the galvanometer
- linearity of measuring potentiometer

The measurement precision of the measuring bridge can be determined by means of the following formula if the resistance of the cable fault is much greater than the bridge resistances.

$$Err[\%] = \frac{I_{G_0}}{I} * \left(\frac{R_{G_0}}{R_s} + \frac{R_{G_0}}{R} + 1 \right) * 100 + 0,15$$

Where:

- I_{G_0} Galvanometer current
- R_{G_0} Internal impedance of galvanometer (20 k Ω)
- I Bridge current = U / R_f
- R Resistance of the measuring potentiometer (100 Ω)

R_s Cable loop resistance

0.15 Linearity error of measuring potentiometer in %

The shirka measurement error is shown in a graph in Figure 20 as a function of R_s and I . According to the table at $I = 100 \mu A$ you get an error of 0.5%.

Example

$R_S = 100 \Omega$

$$I = 100 \mu A = \frac{U}{R_F} = \frac{6V}{60k\Omega} = \frac{6kV}{60M\Omega}$$

4.2 Bridge measurement in accordance with Glaser

4.2.1 With two auxiliary lines and constant line cross-section

Bridge measurement in accordance with Glaser can be used for cable sheath fault location in defective plastic cable sheaths and in unshielded plastic low voltage cables.

The distance to the fault can be determined in relation to the total cable length.

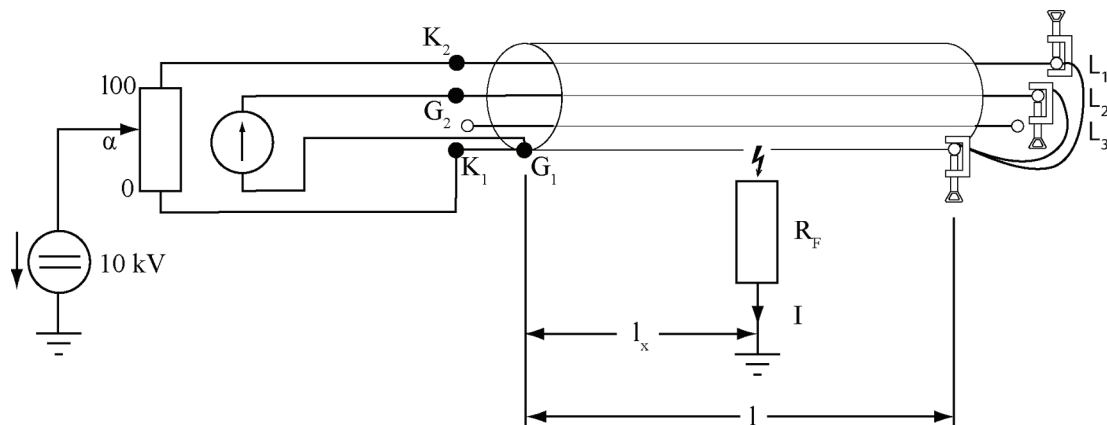

The distance between the start of the cable and the fault is:

$$l_x = \frac{\alpha}{100} * l$$

The distance to the fault can be read directly in metres or as a percentage of the total cable length.

Crocodile clips do not provide an ideal electrical contact! Always clip G_1 and G_2 in front of the HV terminal K_1 or K_2 (see *Connections for bridge measurement* (on page 27)).

This is particularly important for cables with low core cross-sections.

Resistance values for various cross-sections and lengths

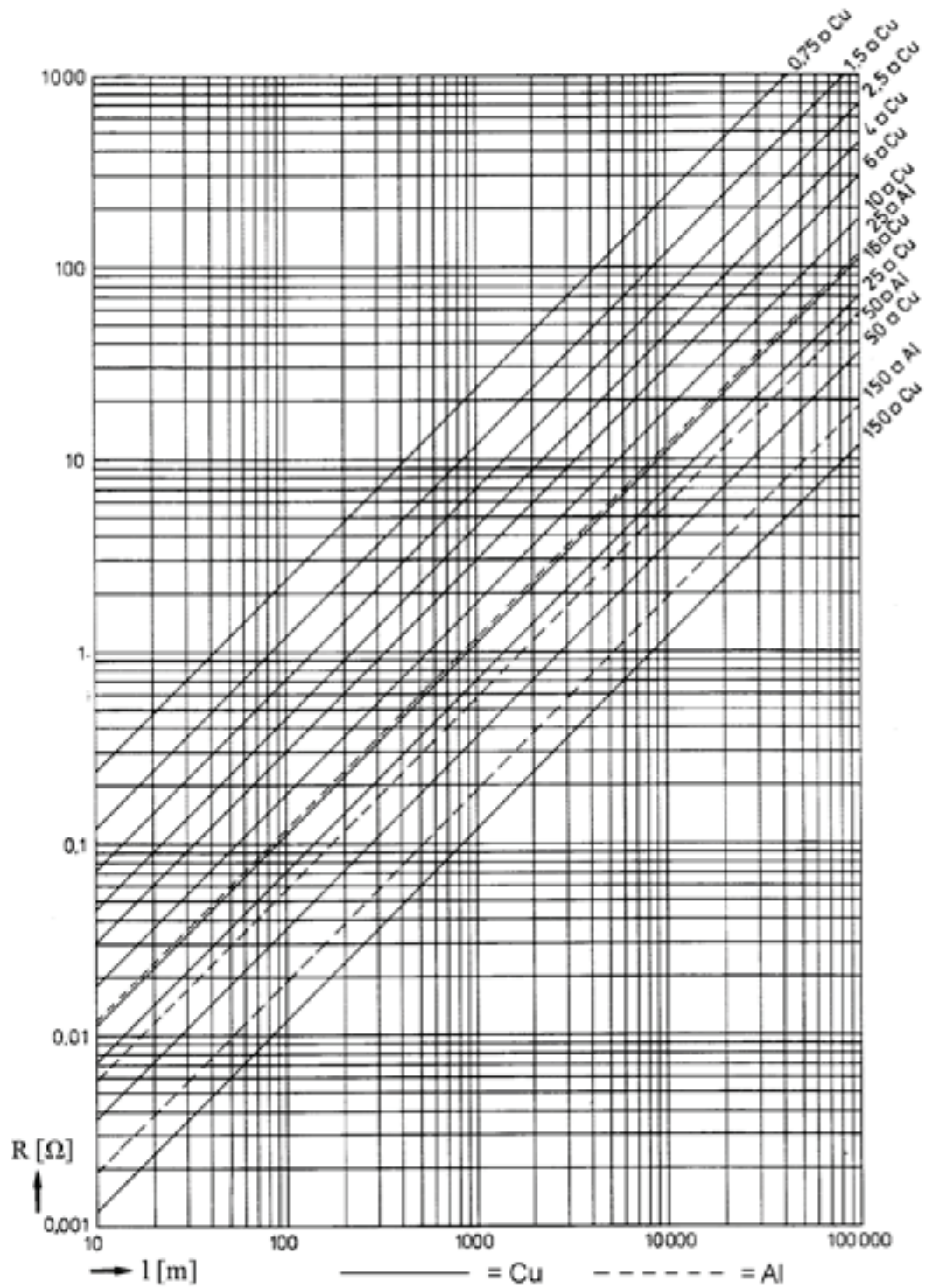

4.3 Bridge measurement in accordance with Murray

4.3.1 With two auxiliary lines and non-constant core cross-section or different specific resistances of the line material

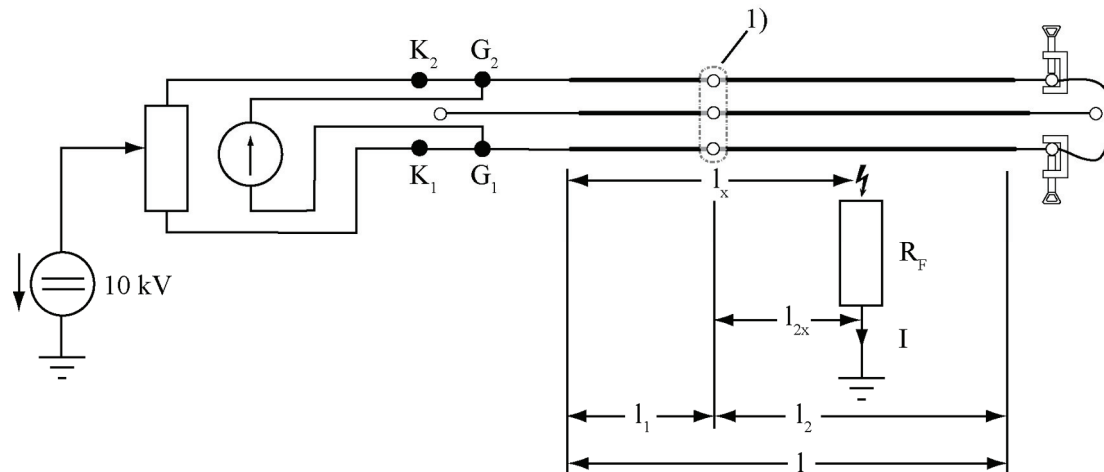

| 1. Joint

The multiple section function can take into account different section parameters.

Example

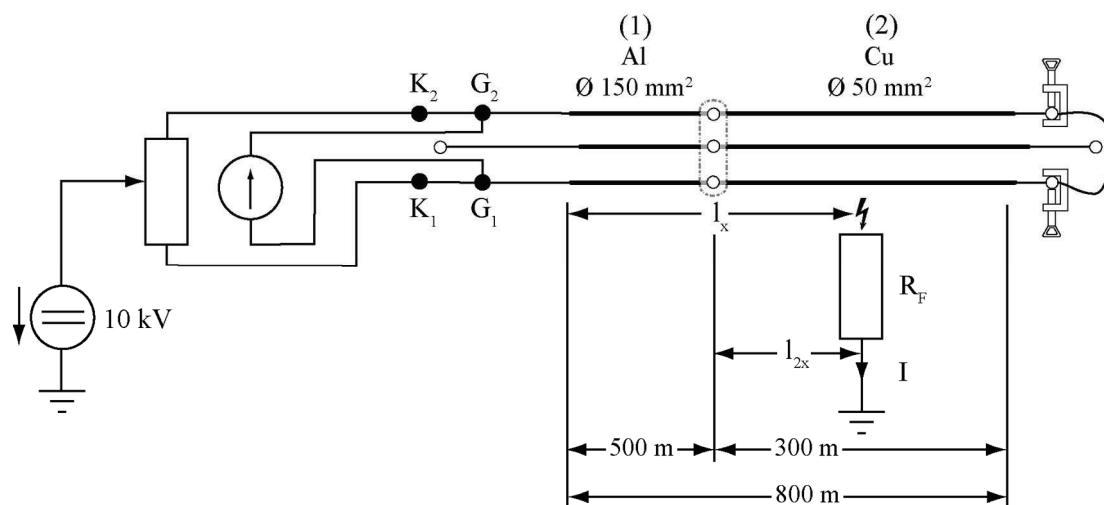

The display shows 79.5 %.

Resistance of the left section (1) (aluminium core Ø 150 mm², l = 500 m):

$$R_F = \frac{0,028 * 500}{150} = 0,0933 \Omega; \left[\rho_{Al} = 0,028 \frac{\Omega * mm^2}{m} \right]$$

Resistance of the right section (1) (copper core Ø 50 mm², l = 300 m):

$$R_1 = \frac{0,0175 * 300}{50} = 0,105 \Omega; \left[\rho_{Cu} = 0,0175 \frac{\Omega * mm^2}{m} \right]$$

Fictitious line length l'_2 :

$$l'_1 = \frac{\rho_2 * A_1}{\rho_1 * A_2} * l_2 = 1,875 * 300m = 562,5m$$

Fictitious overall length l' :

$$l' = l'_1 + l'_2 = 1062,5m$$

Fictitious distance to fault l'_x :

$$l'_x = \frac{\alpha}{100} l' = 0,795 * 1062,5 = 844,7$$

The fault therefore lies in the right section (2).

The true distance between the joint and the fault:

$$l_x = l_1 + l_{2x} = 500m + 183,8m = 683,8m$$

Then:

$$\begin{aligned} & \frac{\alpha}{100} \left(l_1 * \frac{\rho_2 * A_1}{\rho_1 * A_2} * l_2 \right) - l_1 \\ &= 0,795 \left(500 + \frac{0,0175 * 150}{0,028 * 50} * 300 \right) - 500 = 344,7 < 0! \end{aligned}$$

As the fault is located in the right section (2), l_x can be calculated as follows:

$$l_x = 500 \left[0,795 \left(500 + \frac{0,0175 * 150}{0,028 * 50} * 300 \right) - 500 \right] * \frac{0,028 * 50}{0,0175 * 150} m$$

$$l_x = 683,8m$$

4.3.2 With one auxiliary lines and constant core cross-section

With only one good auxiliary wire available, bridge measurement as described in *With two auxiliary lines and non-constant core cross-section or different specific resistances of the line material* (on page 11) is not possible.

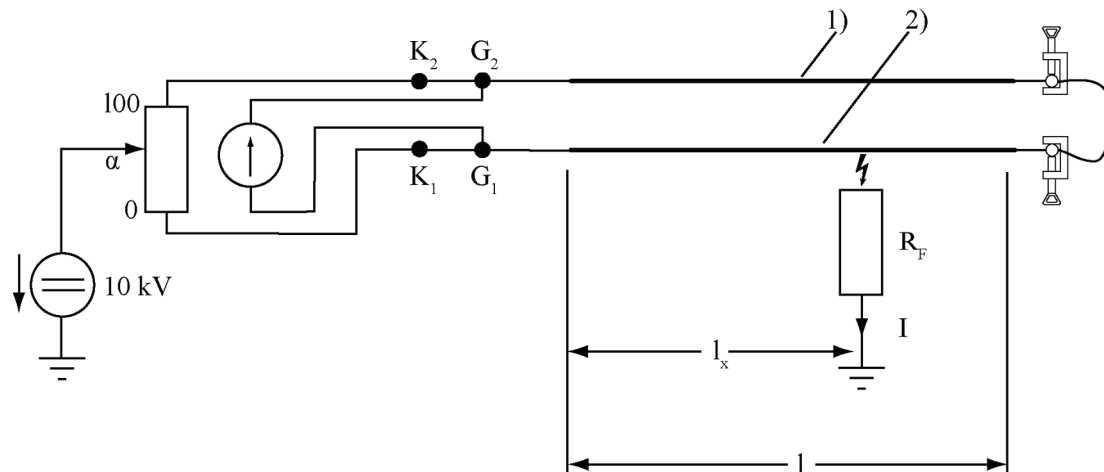

The resistance of the short-circuit bridge is incorporated in the measurement result. Attention must be paid to ensure that the link line has an adequate cross-section, and that the terminal connections have small contact resistances.

The distance between the start of the cable and the fault is:

$$l_x = \frac{\alpha}{100} 2l$$

4.3.3 With one auxiliary line and different core cross-sections

For different core cross-sections or core materials with different specific resistances, the bridge measurement as described in *With one auxiliary lines and constant core cross-section* (on page 13) is not possible.

Example

A cable has a fault between two cores and the cable sheath.

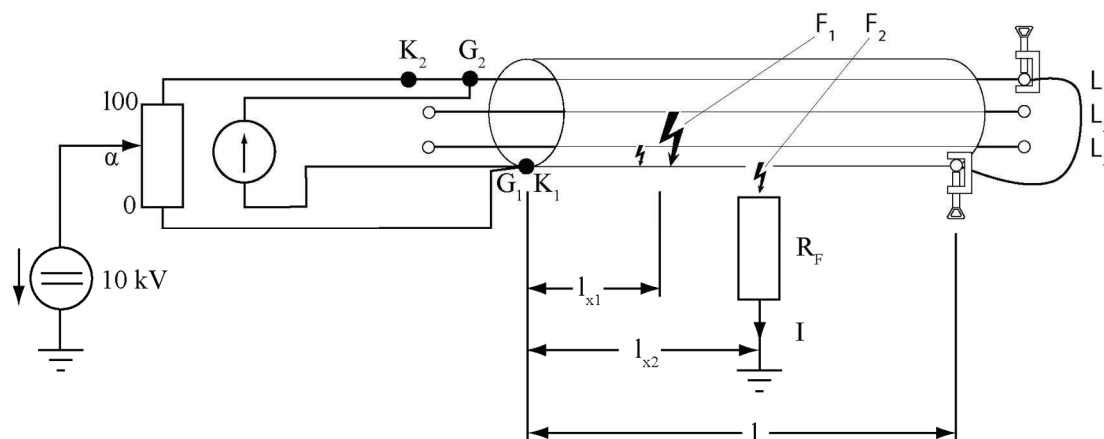

The fault F_1 can be located with the echo or the bridging process. L_1 is used as auxiliary line. If the cable sheath and the auxiliary line L_1 have different cross-sections, a resistance invariant conversion to fictitious lengths must be carried out.

$$R_L = \frac{\rho_L * l}{A_L} = \frac{\rho_S * l'}{A_S} \rightarrow l' = \frac{\rho_L * A_S}{\rho_S * A_L} * l$$

- ρ_L Specific resistance
- A_L Cross-section of the auxiliary line
- ρ_S Specific resistance of the cable sheath
- A_S Cross-section of the cable sheath

Fictitious loop length (conversion based on the cross-section and the cable sheath material):

$$l'_{ges} = l + l' = \left(1 + \frac{\rho_L * A_S}{\rho_S * A_L} \right) * l$$

The distance from the start of the cable to the location of the fault in the cable sheath:

$$l_x = \frac{\alpha}{100} * \left(1 + \frac{\rho_L * A_S}{\rho_S * A_L} \right) * l$$

Example

Cable sheath	25 mm ² Aluminium
Conductor	50 mm ² copper
Cable length	3,200 m
α	25 %

$$l_x = 0,25 * \left(1 + \frac{0,0175 * 25}{0,028 * 50} \right) * 3200m$$

$$l_x = 1050m$$

4.4 Fault location on a cable with branch joint

A measurement at point (A) shows an insulation fault between L_3 and the shield.

A good conductive connection is established at end B between L_1 , L_2 and L_3 . If the fault does not lie between the branch joint and end (B), then a bridge measurement is used to determine the distance between the start of the cable (A) and the branch joint.

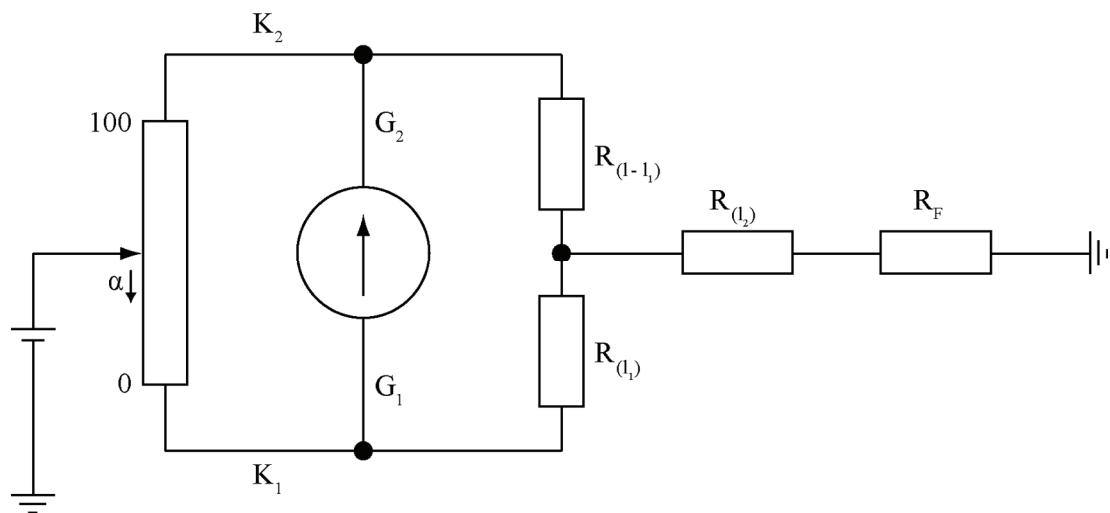
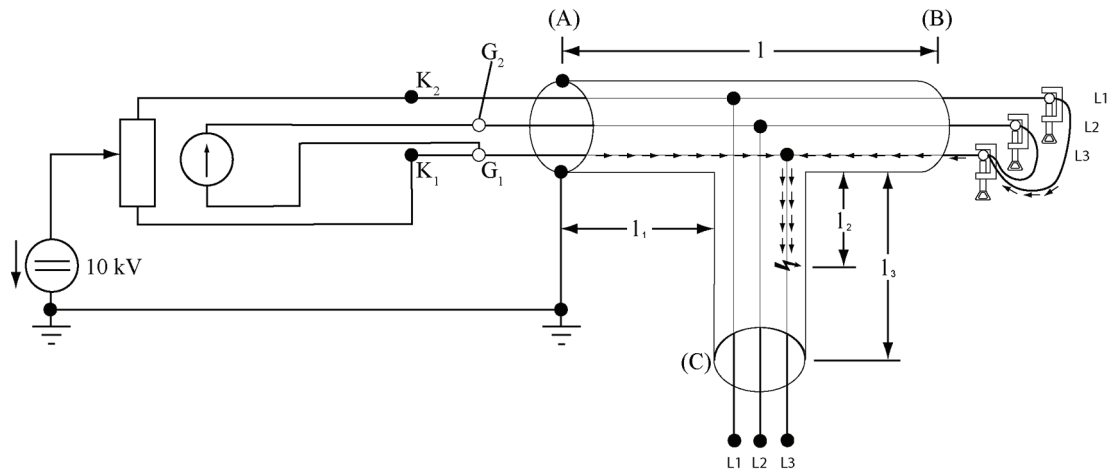

For a second measurement, the short-circuiting bridge between the cores at the end is removed and fitted at the end C.

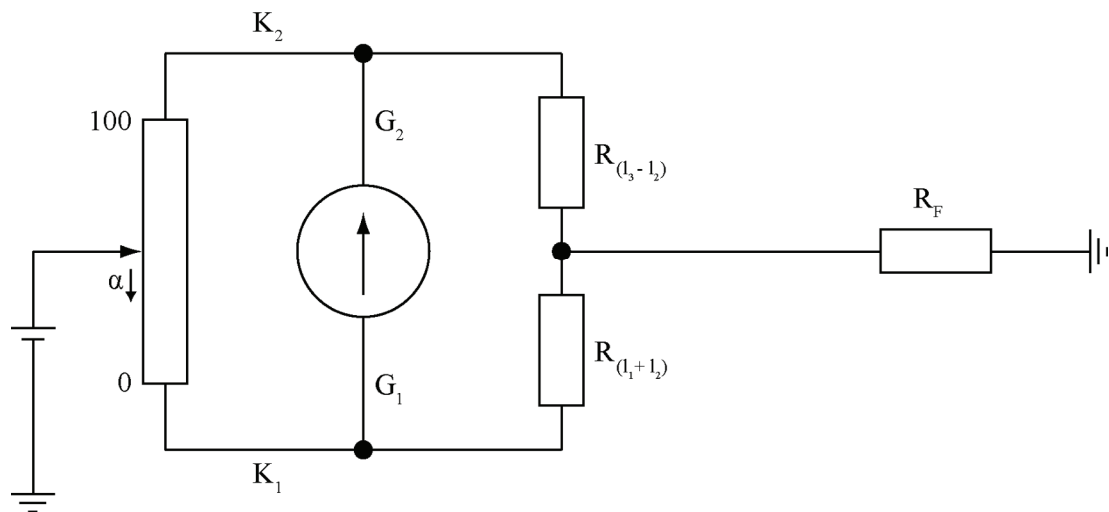
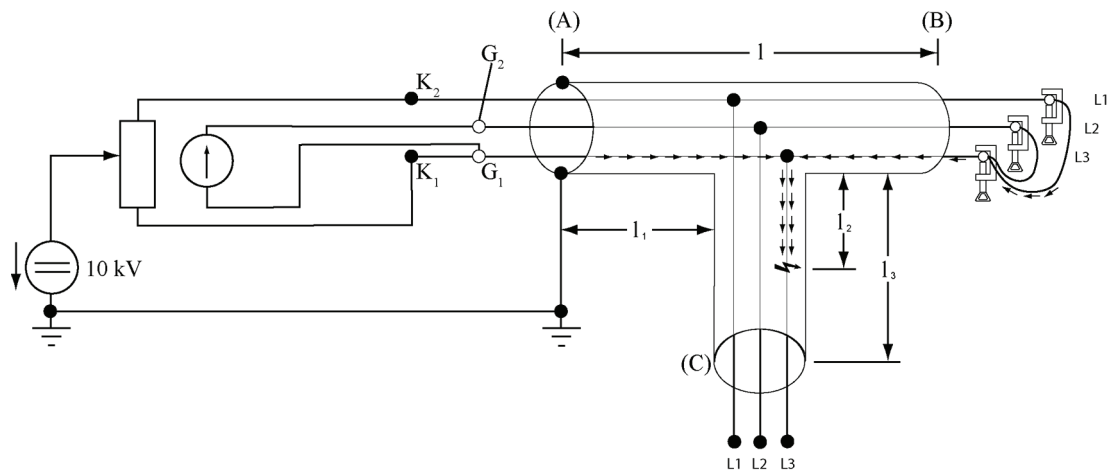

$$\frac{\alpha}{100} = \frac{R_{(l_1+l_2)}}{R_{(l_1+l_3)}} = \frac{l_1 + l_2}{l_1 + l_3}$$

The equation gives the distance between the start of the cable (A) and the cable sheath fault. The distance is given in percentage of the distance between (A) and (C).

4.4.1 Example

First measurement

A cable with a branch joint at 500 m with a fault between the core L_3 and the cable sheath. A short-circuiting bridge is placed between the lines cores L_1 , L_2 and L_3 at each of the ends (B) and (C).

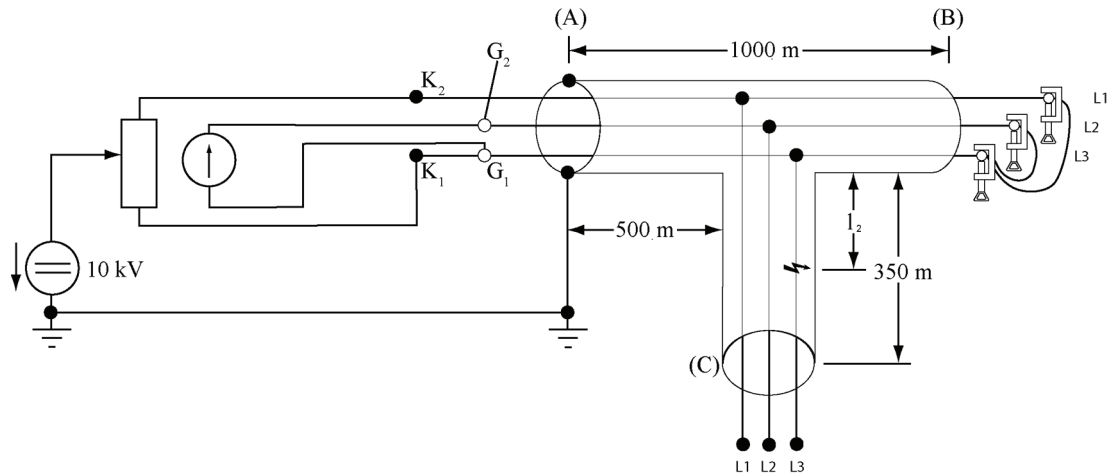

Bridge balancing gives the value 50 %.

$$l_x = \frac{\alpha}{100} * l$$

The distance between the start of the cable (A) and the branch joint was measured. Therefore it can be concluded that the cable sheath fault lies between the branch joint and end (C).

Second measurement

The short-circuiting bridge is removed between the cores at end B and mounted at end C.

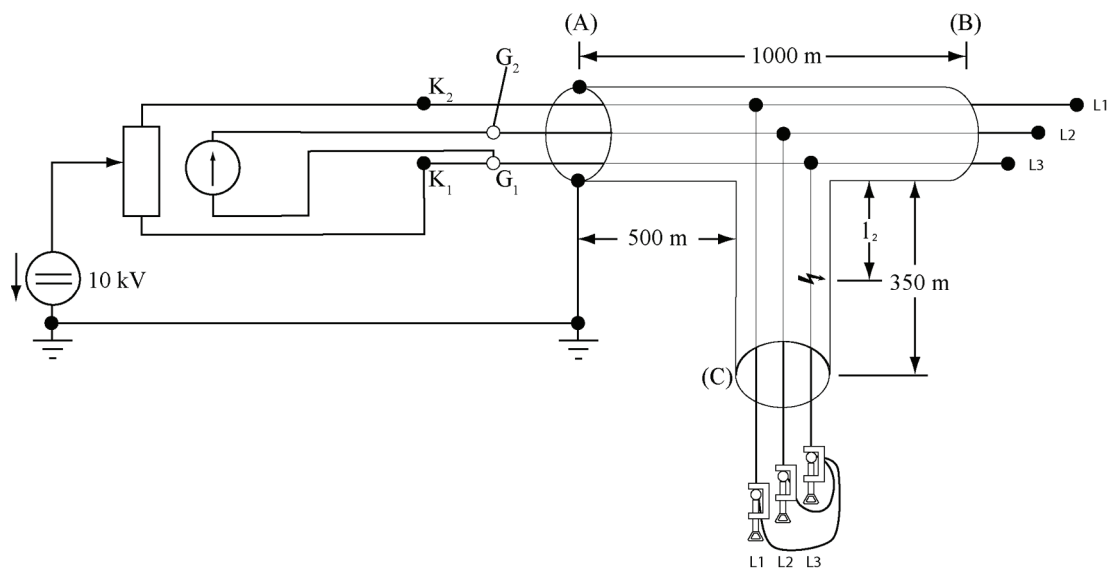

The second bridge balancing gives the value 70.6 %.

$$l_x = \frac{\alpha}{100} * l$$

4.4.2 Unknown distance to branch joint

The distance between the start of the cable (A) and the branch joint can be determined by a further measurement. The measurement is done in accordance with Murray (see *Bridge measurement in accordance with Murray* (on page 11)), where only the healthy cores are connected and a fault (F) is simulated at end (C).

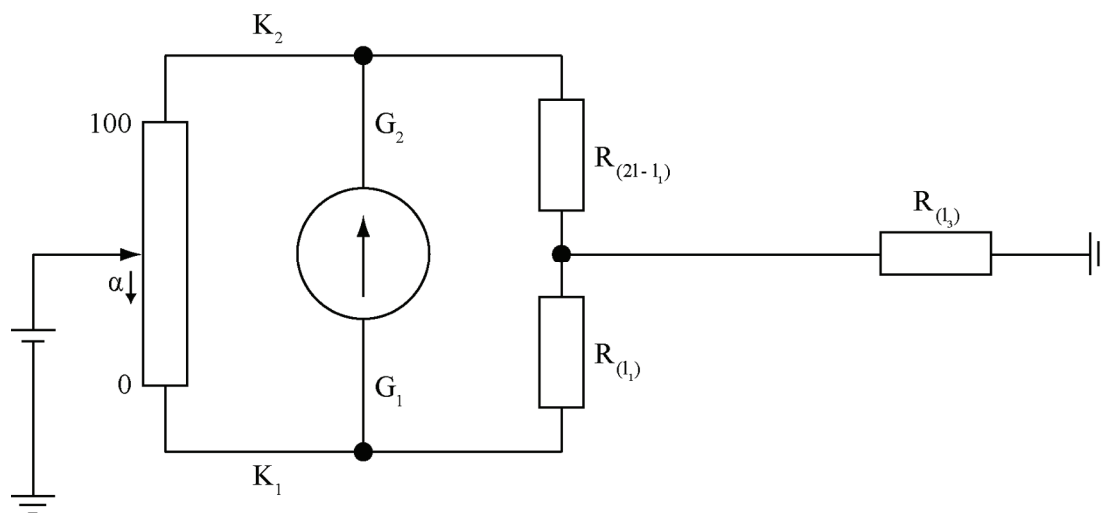
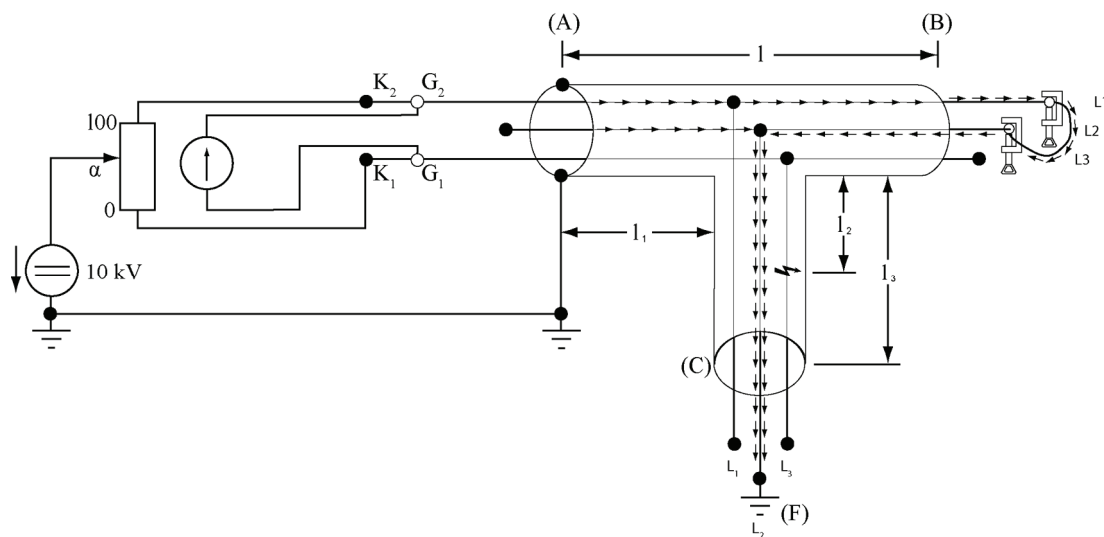

Bridge balancing produces:

$$\frac{\alpha}{1000} = \frac{R_{(l_1)}}{R_{(l_3)}} = \frac{l_1}{l_2}$$

From which:

$$I_1 = \frac{\alpha}{1000} = 2I$$

4.5 Measuring error

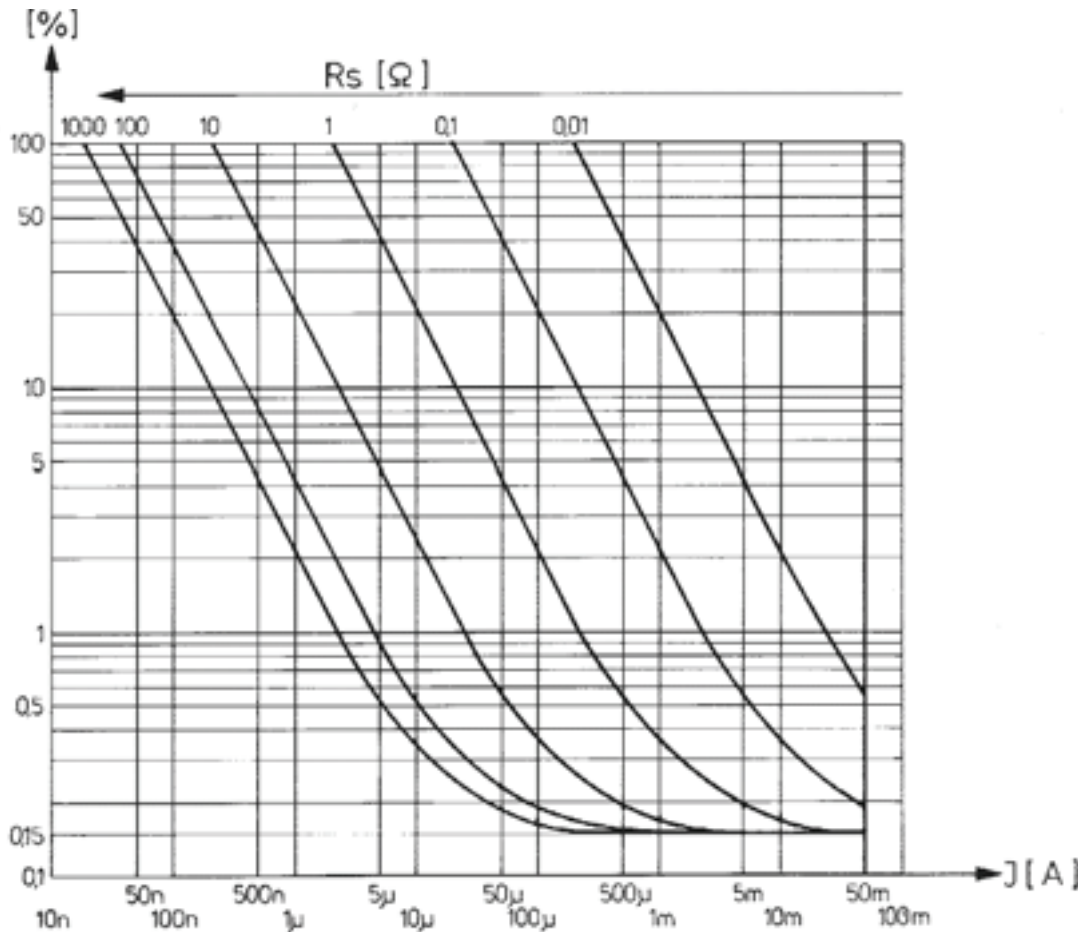

Due to impermissibly high contact resistances at terminal connections, stray DC currents, non-constant core cross-sections and other fault influences, the error may however be even higher.

The figure provides good information on how to adjust the current and voltage limitation. In principle, shirka sets the bridge voltage in such a way that the current required for high accuracy is able to flow.

If only a very low residual current is achieved, the measurement accuracy can be improved through linear interpolation.

Interference voltages

Induced voltages in the measuring circuit through adjacent cables can affect the measurement results. In case of interference signals below 75 mV (at 16 Hz) or 250 mV (at 50 Hz), the accuracy of the measuring results is not affected.

If the interference signals exceed 75 mV (at 16 Hz) or 250 mV (at 50 Hz), a greater tolerance of the measuring result must be considered. The indicator displays the bigger deviation of the measuring result with a warning signal:

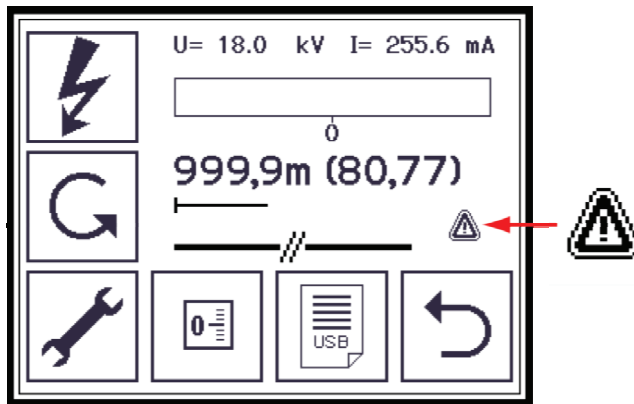

4.6 Comparison of the voltage drop method and bridge measurement

4.6.1 Plastic cable N2XSY with a copper screen

A plastic cable N2XSY with a copper screen (25 mm² cross-section) has an insulation fault in the outer plastic sheath at 50% of the total length. The total length is 1000 m.

Measurement with the voltage drop method

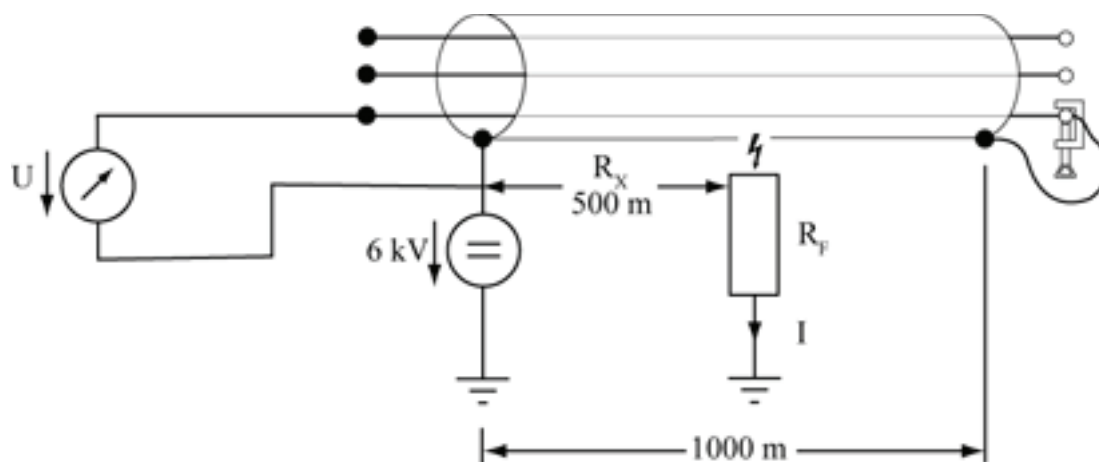

$$R_x = \frac{500 \text{ m} * \rho_{cu}}{25 \text{ mm}^2} = \frac{500 * 0,0175}{25} \Omega = 0,35 \Omega$$

To measure U, a 60 mV moving-coil measuring instrument of Class 1.5 is used. To achieve a pointer deflection of 50 % requires a measuring current of

$$\frac{30 \text{ mV}}{0,35 \Omega} = 86 \text{ mA}$$

With a supply voltage of max. 6 kV, the fault resistance R_F may not be greater than 70 k Ω .
The measuring error in this case can be e.g. 3%:

$$\pm 0,015 * 60mV = \pm 0,9mV = 3\%$$

The voltage source must provide 516 W of power.

Measurement with the measuring bridge

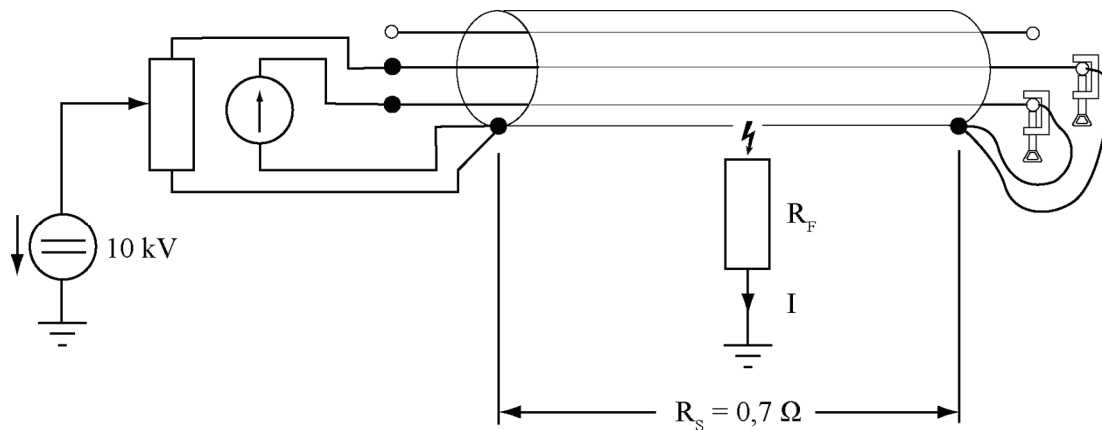

For a measurement reliability of 1 % Figure 20 gives a minimum measuring current of $I = 500 \mu A$ for $R_s = 0.7 \Omega$.

Accordingly, the fault resistance can be maximum 12 M Ω . The required power for the voltage source is: 3 W.

4.6.2 Shielded low voltage cable with a large cross-section

The advantage of the bridge measuring principle becomes even clearer when locating earth faults on unshielded low-voltage cables with large cross-sections.

The cable sheath is replaced by a defective single wire made of copper, with a cross-section of 150 mm².

$$R_s = \frac{1000m * 0,0175 * mm^2}{150mm^2 * m} \Omega = 0,117\Omega$$

Measurement with the voltage drop method

For the voltage drop method, a measuring current of $I = 0.515 A$ is required for a voltage drop of 30 mV. At 6 kV R_F max. = 11.6 k Ω

The voltage source must provide

$$6000V * 0,515A = 3kVA$$

of power.

Measurement with the measuring bridge

For a measuring precision of 1%, a minimum measuring current of $I = 2 mA$ can be taken for $R_s = 0.117 \Omega$.

Accordingly, the fault resistance can be maximum 3 M Ω . The required power for the voltage source is 12 W.

5 OPERATING CONTROLS



Operating unit	22
Connecting the ground line	23
Operating the menu	23
Voltage and current display	23

5.1 Operating unit

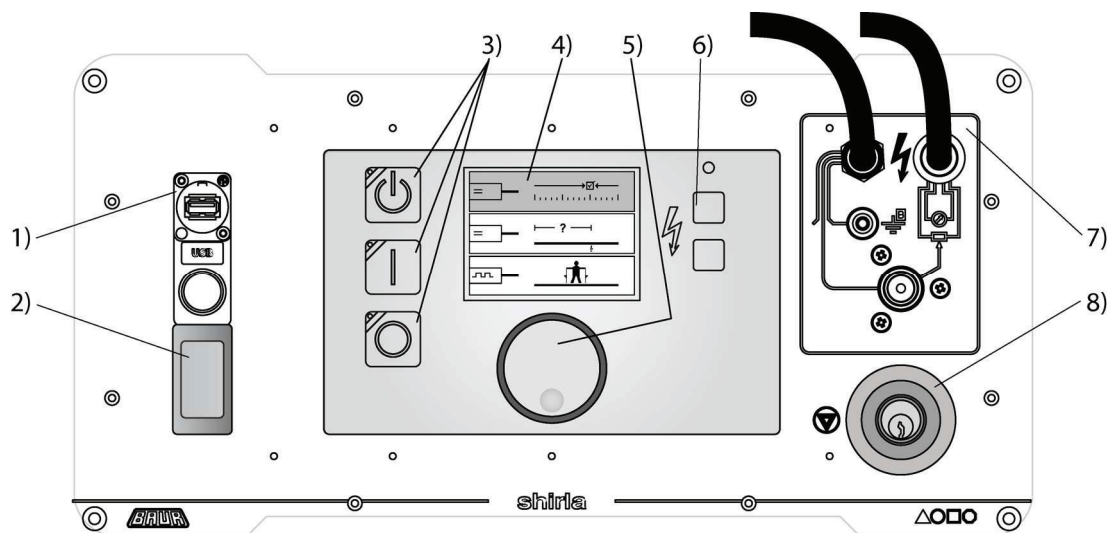

1. USB socket
2. Main switch
3. HV keys
4. Display
5. Selector knob
6. Status indicator high voltage
7. Connection panel
8. Emergency-off switch

5.2 Connecting the ground line

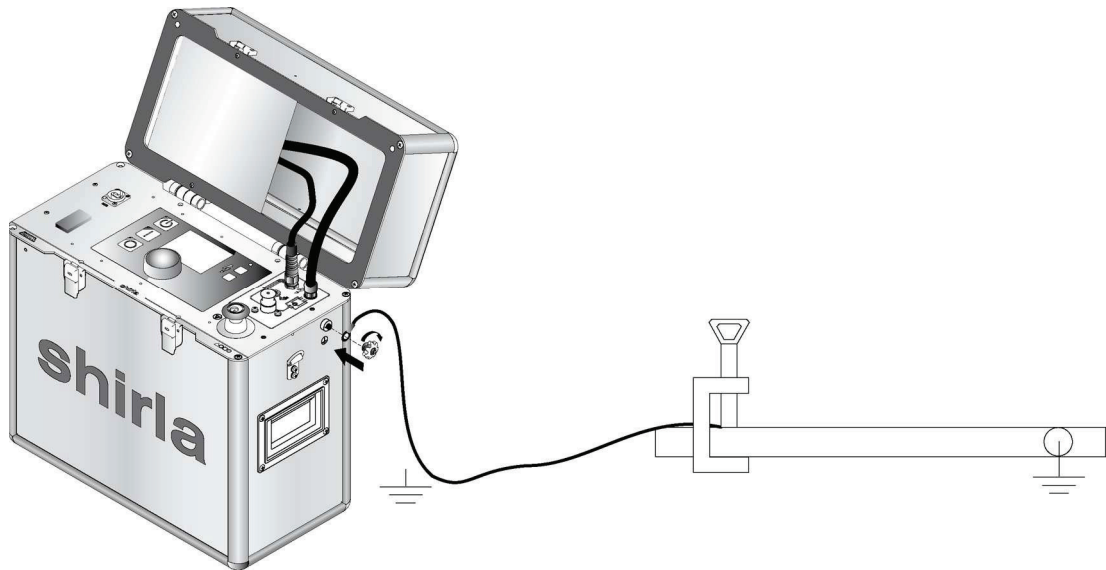

5.3 Operating the menu

Selecting the fields in the display

Turn the selector knob to move the selection highlighting over the fields. To select press the knob.

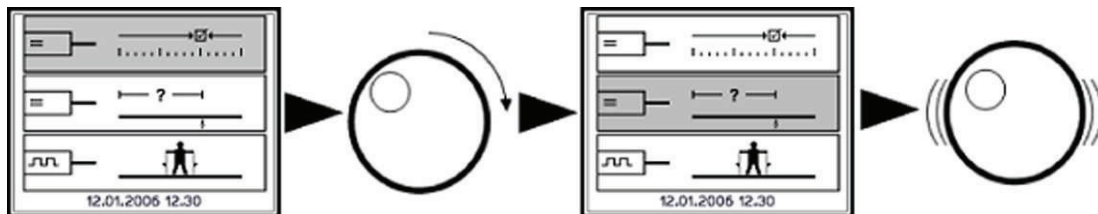

5.4 Voltage and current display

Different values are used for display and input depending on the selected voltage shape.

	DC test	Sheath fault location
Voltage / current limits	Maximum	Maximum
Voltage / current display	Actual value	Actual value

6 COMMISSIONING



Important basic rules	24
Preparing the device for cable or cable sheath testing	25
Connections for bridge measurement	27
Using the menu	29
Switching high voltage on and off	30

6.1 Important basic rules

shirla is used for testing disconnected cable lengths. Before connecting the device to the cable length to be tested you must ensure that the cable is disconnected and deenergised. Observe the statutory and operational safety regulations!



Never operate the device in a potentially explosive atmosphere!

The object under test is discharged by the integrated discharging device after completion of a test. Before any contact with the object under test it must be earthed. Voltage may still exist at the object under test after a breakdown in the cable or after an interruption in measurement (e.g. by pressing the emergency-off button) and therefore it must first be completely discharged and then earthed before any contact is made.

For proper discharge and/or earthing, the protective ground cable of the rod used must be solidly connected to the station ground or protective ground. Touch the rod only by its handle when discharging and/or earthing the rod. The minimum discharge time stipulated on the discharge rod must be observed when discharging it.

6.1.1 Discharging and earthing

Voltage may still exist at the object under test after a breakdown in the cable or after an interruption in measurement (e.g. by pressing the emergency-off button) and therefore it must first be completely discharged at shirla and then earthed before any contact is made.

For proper discharge and/or earthing, the protective ground cable of the rod must be solidly connected to the protective ground. Touch the rod only by its handle when discharging and/or earthing the rod.

Discharging

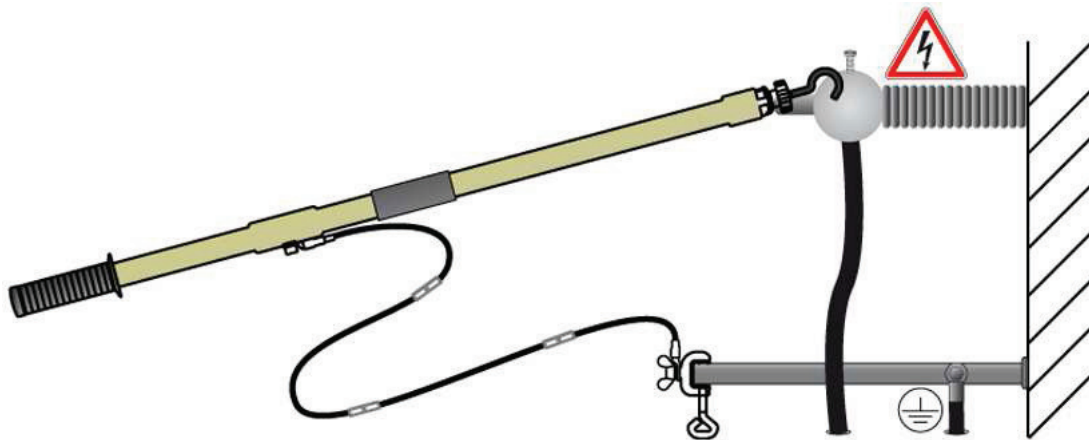

The protective ground cable of the discharge and earth rod must be connected to the station ground. The object under test is touched by the tip of the rod.

The minimum discharge time stipulated on the discharge rod must be observed when discharging it.

Earthing

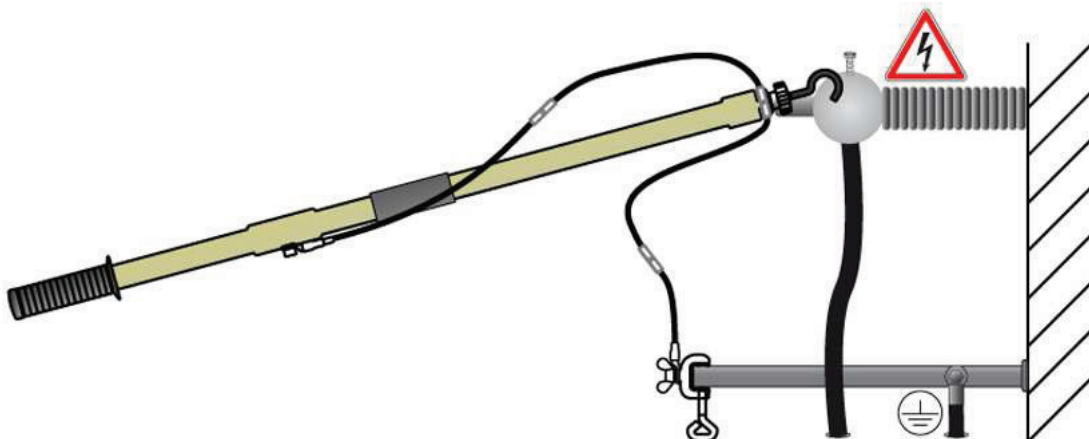

The discharge resistance of the combined discharge and earth rod can be short-circuited to the earth of the object under test.

6.2 Preparing the device for cable or cable sheath testing

6.2.1 Preparing the cable

Disconnect the object under test on all contacts, secure it against being switched on again and check that it is deenergised. Isolate adjacent live parts. It must be ensured that when high voltage is applied there can be no arcing or breakdown to the adjacent parts of the station or the cabling. In the case of multi-wire objects under test, all wires, except the ones being tested, must be connected to the station ground. Clean the terminals if necessary.

6.2.2 Connecting the protective ground cable

Connect shirla with the supplied protective ground cable (yellow-green) at the protective ground connector (connection panel) to the station protective ground. A screw terminal is provided on the protective ground cable for this.

6.2.3 Connecting the high voltage feed cable for testing

Connect the shielding connector of the high voltage feed cable to the earthed sheath of the cable being tested. Connect the high voltage connector with the corresponding conductor of the cable under test. To do this attach the supplied clips to the high voltage feed cable.



Observe the advice about discharging and earthing and the general safety regulations!

6.2.4 Connecting to various cable types

Cable sheath fault pin-pointing on 3-phase shielded cable

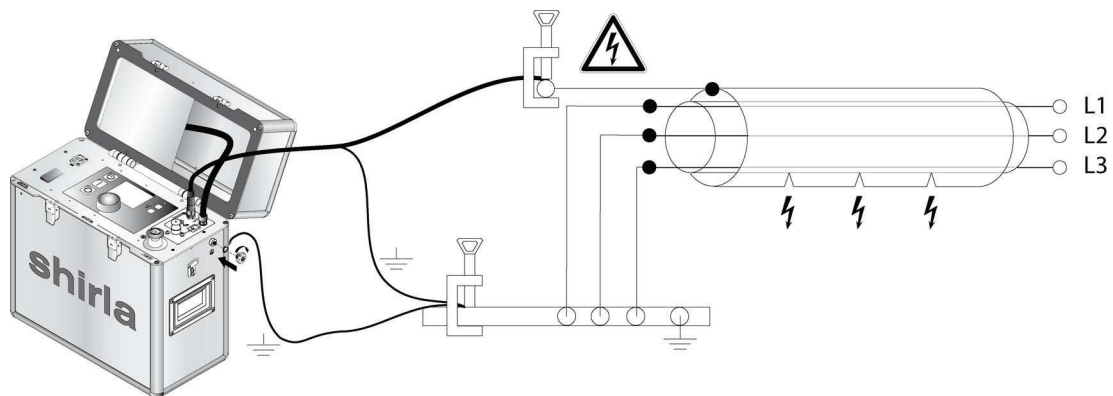

Cable sheath test on 3-phase shielded cable

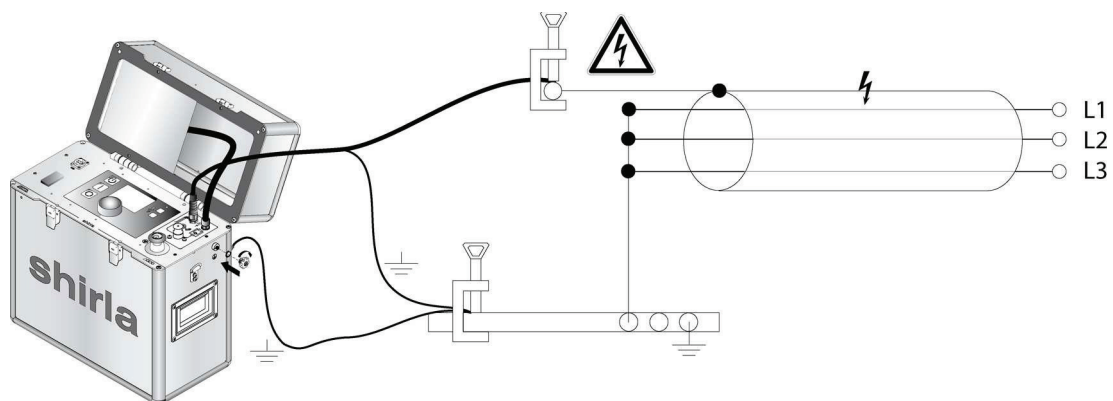

Cable sheath test on 1-phase shielded cable

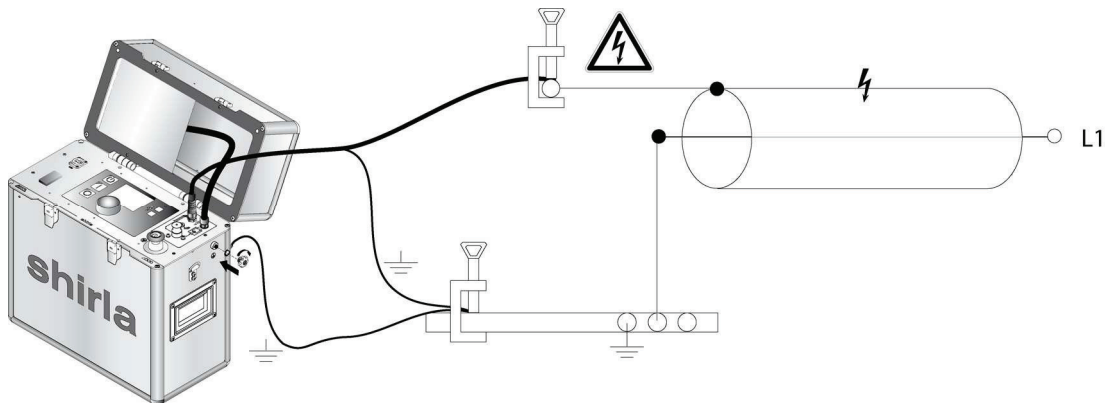

Cable test on 3-phase unshielded cable

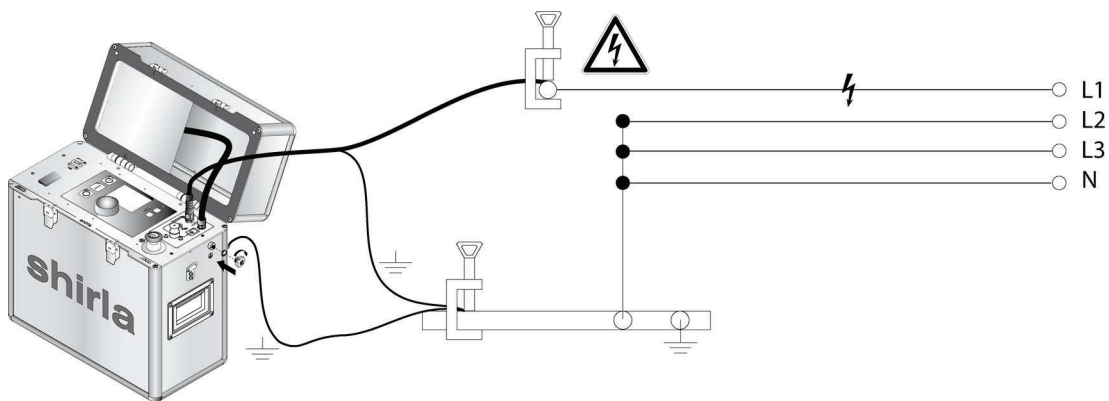

6.3 Connections for bridge measurement

The terminals K_1 and G_1 are connected to the defective wire.

Bridge measurement in accordance with Glaser

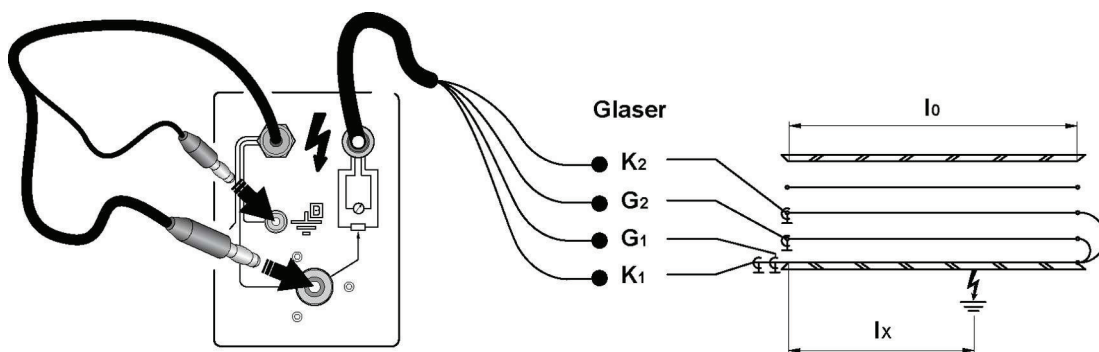

Bridge measurement in accordance with Murray

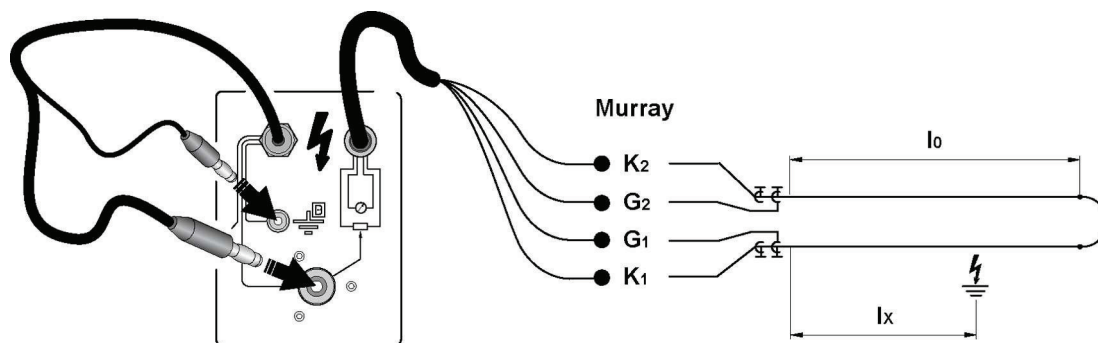

Attention must be paid to ensure that the potential terminals for the galvanometer G_1 and G_2 are located behind the terminals of the measuring potentiometer K_1 and K_2 , as seen from the bridge. This enables the contact transition resistances of the terminals K_1 and K_2 and the resistances of the measuring lines L_1 and L_2 to be added to the relatively high-resistance part resistances of the measuring potentiometer (1), and not to the resistances of the cable loop (2), which would otherwise be very low-ohmic.

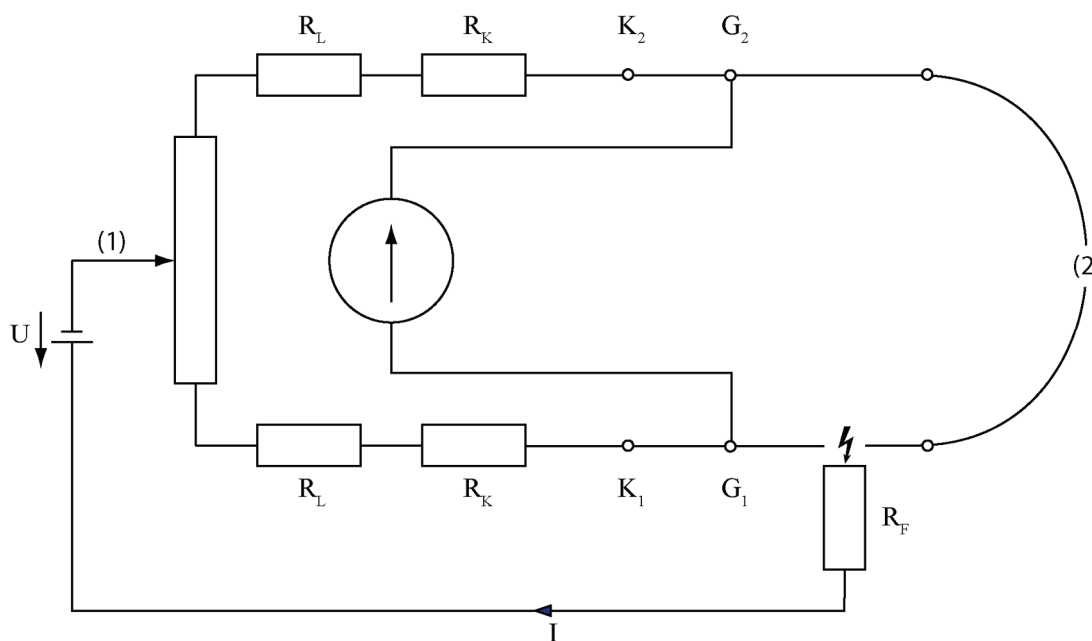

- R_K : Contact transition resistances of terminals
- R_L : Measuring line resistance

6.4 Using the menu

The main menu appears after the mains connection and commissioning. All applications can be selected from the main menu.

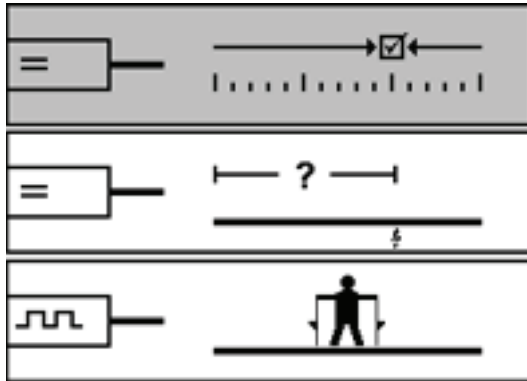

The main menu allows the user to select from a range of uses.

- Cable and cable sheath testing
- Fault location / measuring bridge
- Fault pin-pointing

Turning the selector knob allows you to choose between the various menu points.

See also:

- *Cable and cable sheath testing* (on page 32)
- *Fault prelocation / measuring bridge* (on page 36)
- *Fault pin-pointing* (on page 42)
- Turn the selector knob clockwise

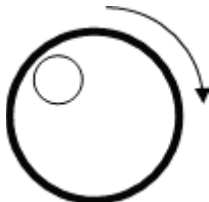

The selection highlight moves downwards.

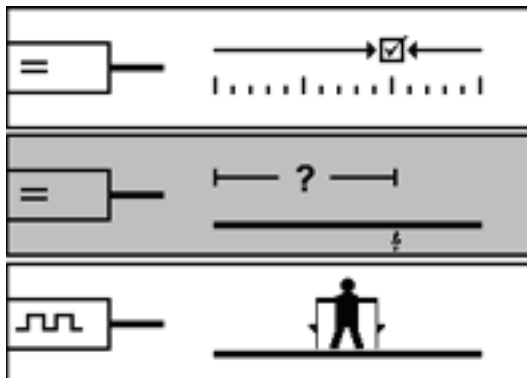

- Press the selector knob

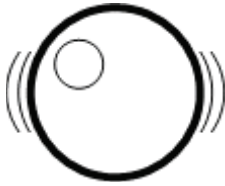

The current selection is confirmed.

6.5 Switching high voltage on and off

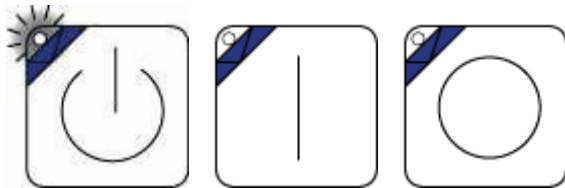

High voltage may be switched on and off on the shirla testing device using the three keys to the left of the display.

The yellow illuminating indicator light integrated into the key indicates which key needs to be pressed for the next step.

The test is started with the activation of the high voltage. When carrying out bridge measurement (see *Fault prelocation / measuring bridge* (on page 36)) the activation of the high voltage must take place after zero point compensation. High voltage is not necessary for making the system settings or for entering test procedures.

The green and the red indicator lights show the status of the system.

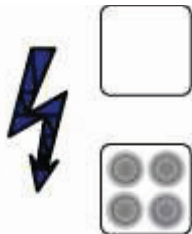

Switching on the main switch places the device in the Ready for operation state. This state is indicated by the illumination of the green light.



- Press the key with the illuminated indicator light for at least 1 second

Displayed by a red flashing warning light (6 seconds)

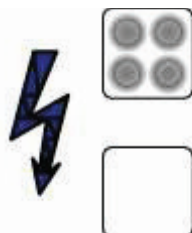

To set the device in operation the key must be pressed when the light is flashing. If the key is not pressed within this time the device reverts to the Ready for operation state.

- Press the key with the illuminated indicator light for at least 1 second



The In operation state is indicated by the red illuminated warning light.



Danger: Risk of injury due to high-voltage!

Solution: Protect the test object. Pressing the key switches the device off.

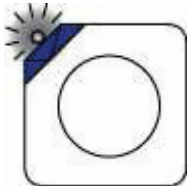

This key activates the discharge device, which discharges the cable through resistances. The device switches to the Ready for operation state again.

For safety reasons the high voltage connection must be earthed before making any contact.

After activating the emergency-off switch shirla returns to the Ready for operation state. The emergency-off message must be confirmed.



7 CABLE AND CABLE SHEATH TESTING



Settings	33
Carrying out the tests.....	34
Ending a test early	35

Connect the single pole HV connection cable for the high voltage test. The connection may be made using the G-clips or the crocodile clips.

The four-pin connection cable remains galvanically isolated and can be stored in the cable compartment.

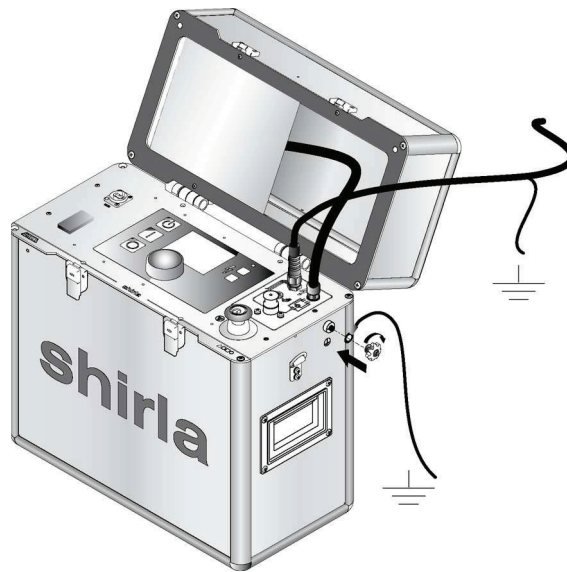

Cable and cable sheath testing mode is preselected.

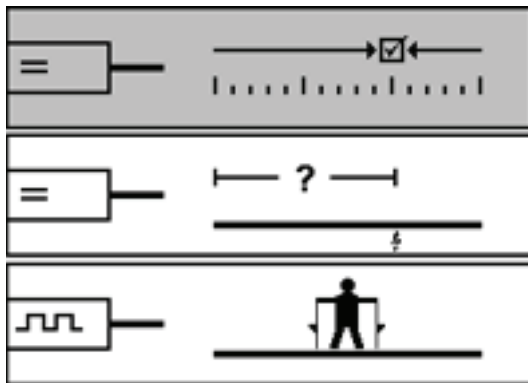

- Press the selector knob

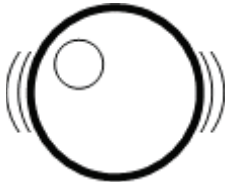

The current selection is confirmed.

You can access the "Test" menu from the main menu. Here you can adjust the test voltage, duration and the current limit.

By selecting the U, I or time value with the selector knob and by pressing the selector knob you can set the value for the subsequent measurement.

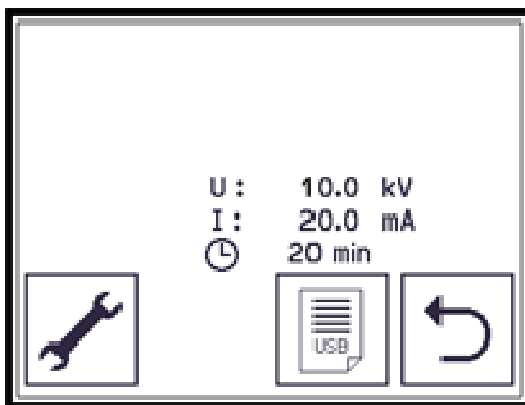

7.1 Settings

By selecting the settings button you can access the menu for setting the limit parameters and the date and time.



Setting the date and time

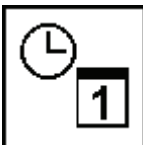

Setting the maximum value for the adjustable voltage and the maximum test current



Back to the selected menu



Log function



The test report or the results of the test are written to the USB stick. The USB stick must be inserted.

Any number of measurement points can be used during the test by selecting and confirming the reporting field. The measurement points appear in the test report with a record of the time, leakage current and voltage.

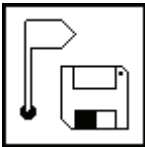

7.2 Carrying out the tests

- Activate high voltage



- Apply high voltage

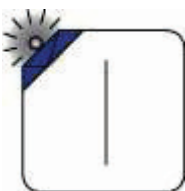

Danger: Risk of injury due to high-voltage!

Solution: Protect the test object. As soon as the high voltage is switched on the red warning light illuminates and the test begins automatically.

After the test period has expired shirla automatically switches off and produces the test report.

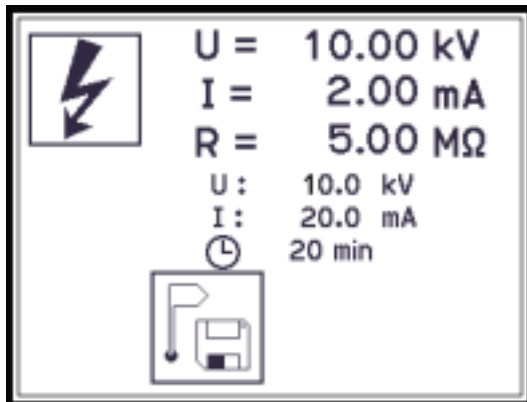

7.3 Ending a test early

A test can be ended manually at any time.

The outlet is discharged by the discharge unit but must be earthed before it is touched.

- To end the test, switch off shirla

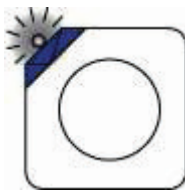

8 FAULT PRELOCATION / MEASURING BRIDGE



Settings	36
Sections	37
Zero balancing	39
Repeating measurements.....	41
Ending measurement early.....	41

8.1 Settings

- Connect the 4-pin pole measuring bridge cable
- Connect terminals G_1 , G_2 , K_1 and K_2 according to the measuring method (Murray or Glaser) and ensure that the supplied G-terminals are used.

Crocodile clips do not provide an ideal electrical contact! Always clip G_1 and G_2 in front of the HV terminal K_1 or K_2 (see *Connections for bridge measurement* (on page 27)).

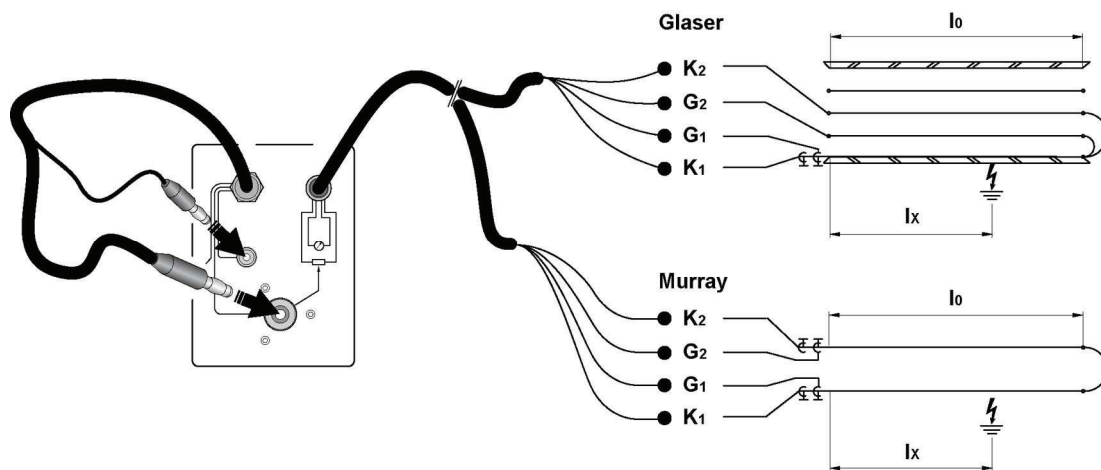

The fault prelocation is selected automatically when inserting both test cable plugs.

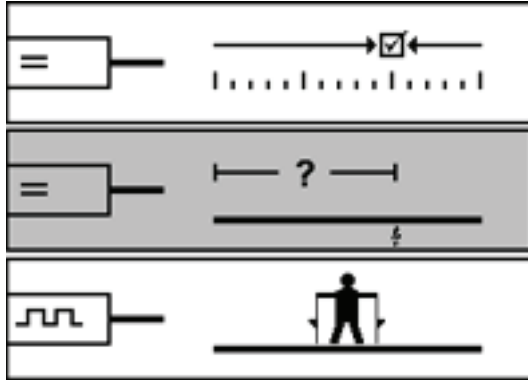

Selection menu for bridge measurement

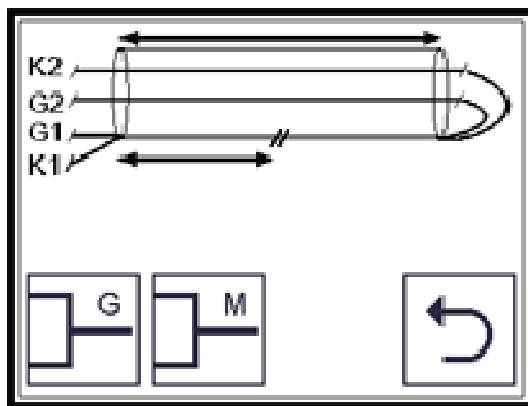

➤ Select Glaser or Murray method



➤ Back to selection menu

8.2 Sections

shirla allows the user to define up to 50 different cable sections. Different core cross sections and materials affect the magnitude of the specific wire resistances. As the measurement is defined as the average of the total length, this can lead to results that deviate from the actual fault distance.

In these circumstances you can define further sections. As soon as more than one section is defined the device prompts you to define the section cross-section and material (Al or Cu).

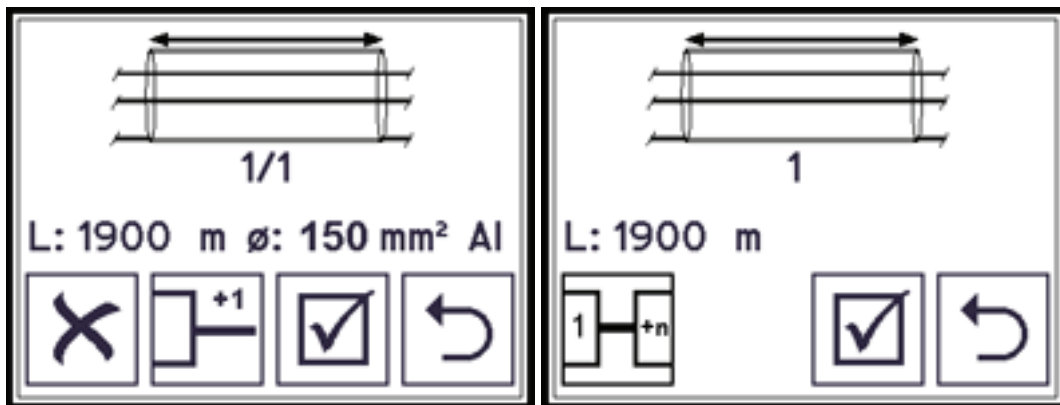

8.2.1 Working with only one section

- Define the length
 - Turn quickly = coarse adjustment
 - Turn slowly = fine adjustment

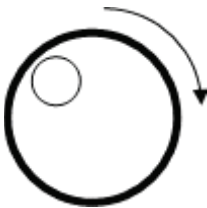

8.2.2 Adding sections

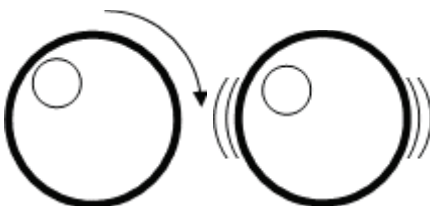
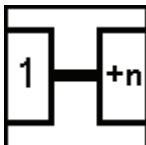

1. Select division into multiple sections
The device prompts you to define the cross-section and material for the 1st section. To change values:
2. Select by pressing the knob
3. Turn the selector knob to set the value
4. Confirm by pressing the knob
5. Select the material by turning the selector knob
Al = aluminium, Cu = Copper
6. Confirm by pressing the knob

Pressing the button adds the next section. The length, cross-section and material must then be defined.

7. Select the next continuous number
8. Further sections can be added or deleted as required.

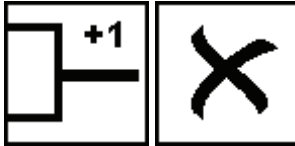

Confirm the input and go back to the selection menu



By selecting the settings button you can access the menu for setting the limit parameters and the date and time.



8.3 Zero balancing

Display of the actual value during measurement

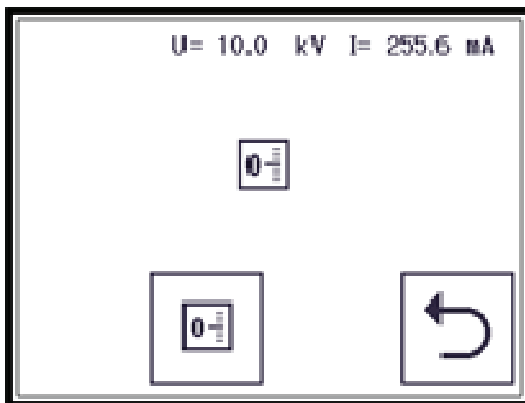

- Bridge balancing

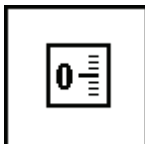

After the zero balance symbol disappears the bridge is balanced.

- Activate high voltage



- Apply high voltage

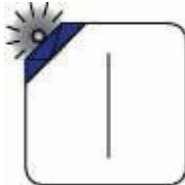

The measurement begins immediately after high voltage is applied.



Danger: Risk of injury due to high-voltage!

Solution: Protect the test object.

During the balancing phase the zero balance symbol appears and goes out as soon as the balance has been successfully carried out.

The measurement results are shown in metres (with the different section characteristics taken into account) and given as a percentage of the total length.

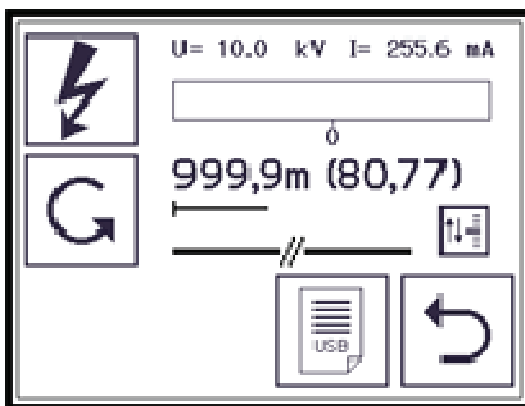

In case the zero balance is affected by voltage disturbances, after a certain time shirla calculates the arithmetic mean from the fluctuating values.

If the interference signals exceed 75 mV (at 16 Hz) or 250 mV (at 50 Hz), a greater tolerance of the measuring result must be considered. The indicator displays the bigger deviation of the measuring result with a warning signal:

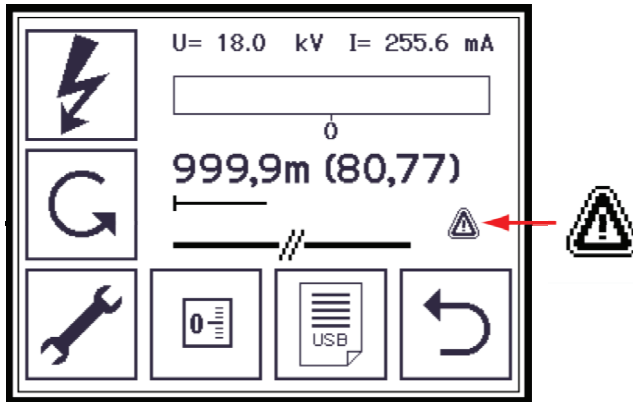

8.4 Repeating measurements

Restart

- Select restart field



The measuring bridge is compensated again and then the measurement starts automatically. shirla does not need to be switched off before repeating measurements.

Log function

The measurement report or the results of the measurement are written via the USB interface. The USB stick must be inserted.



Ending measurement

- To end the measurement switch off shirla

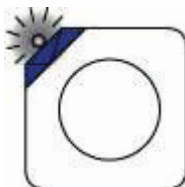

8.5 Ending measurement early

A measurement can be ended manually at any time.

The outlet is discharged by the discharge unit but must be earthed before it is touched.

9 FAULT PIN-POINTING



Connections and settings	42
Ending measurement early	44

9.1 Connections and settings

Connect the single pole HV connection cable for the high voltage test. The connection may be made using the G-clips or the crocodile clips.

The four-pin connection cable remains galvanically isolated and can be stored in the cable compartment.

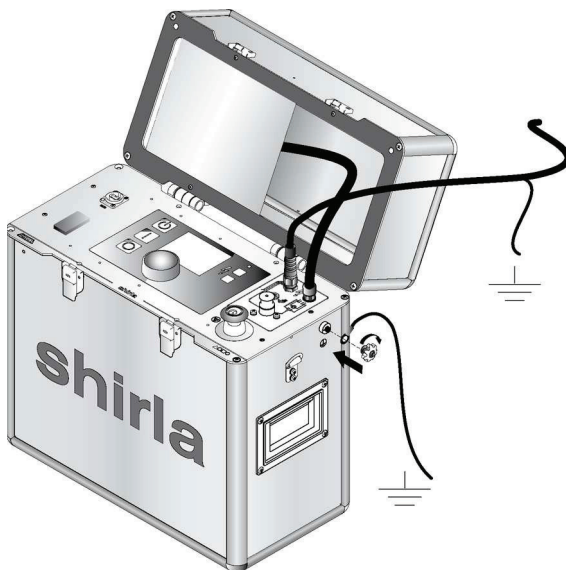

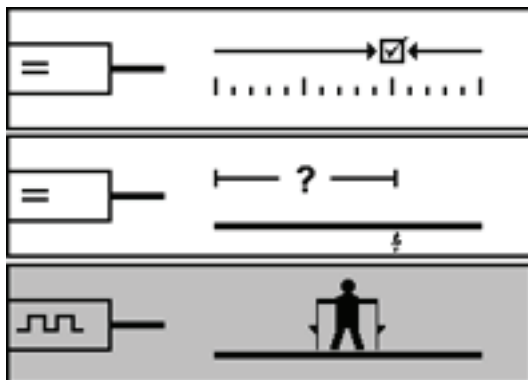

1. Select fault pin-pointing

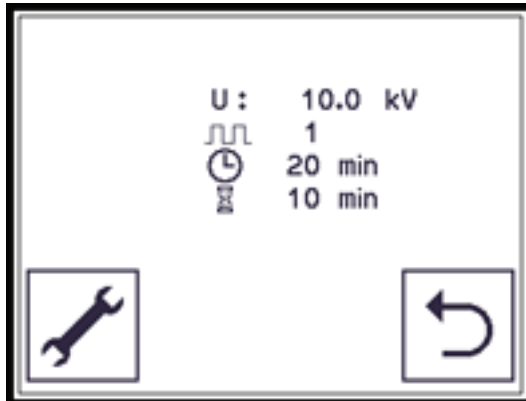

By selecting the settings button you can access the menu for setting the limit parameters and the date and time.



2. Make settings

- Pulse voltage (U:) select
- Select pulse pattern () (see *Cable and cable sheath fault pin-pointing* (on page 5))
- Set pulse duration () in minutes
- Set delay time () until start of pulse operation

3. ▶ Activate high voltage

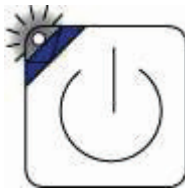

4. Apply high voltage



Pulse operation begins immediately after switching on or the expiry of the set waiting time.



Danger: Risk of injury due to high-voltage!

Solution: Protect the test object. The initiated sequence of impulses is shown by the flashing high voltage arrow and the pulse symbol. shirla shuts off automatically after the defined pulse time lapses.

9.2 Ending measurement early

Fault pin-pointing can be ended manually at any time.

The outlet is discharged by the discharge unit but must be earthed before it is touched.

- To end the fault pin-pointing, switch off shirla

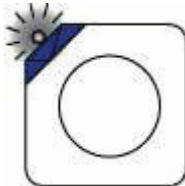

10 UPDATING SOFTWARE

BAUR software is continuously updated. The software can be updated to enable the latest developments to be incorporated in your device.

In case of queries, please contact BAUR Prüf- und Messtechnik GmbH or the BAUR representative.

11 TECHNICAL DATA

General

Input voltage	110 VAC ... 240 VAC, 50 Hz / 60 Hz
Power consumption	200 VA
Display	Illuminated digital LCD display, automatic brightness adjustment, 320 x 240 dots
Operating temperature	-20 ... +50 °C
Storage temperature	-40 ... +60 °C
Relative humidity	Non condensing
Dimensions (W x H x D)	440 x 490 x 220 mm
Weight	< 20 kg

Testing

Output voltage	0 ... 10 kV
Output current	10 mA @ 5 kV, 5 mA @ 10 kV
Current indicator resolution	1 µA
Current indicator accuracy	± 10 µA
Resistance measurement	Yes
Resistance measurement range	0,01 MΩ ... > 1 GΩ
Voltage and current limitation	adjustable

Fault prelocation

Measuring method	Measuring bridge in accordance with Murray and Glaser
Measuring voltage / bridge voltage	100 V ... 10 kV, adjustable
Measuring current	up to 50 mA, adjustable
Measuring circuit accuracy	± 0.1 %
Measuring sequence	fully automatic
Definable cable sections	50
Voltage and current limitation	Yes

Fault pin-pointing

Pulse voltage	100 V ... 10 kV
Pulse current	max. 700 mA
Pulse pattern	3 Pulse pattern selectable

12 MAINTENANCE



Service personnel	47
Error messages.....	48
Error codes	48
Cleaning.....	50

12.1 Service personnel

BAUR Service personnel

- have the appropriate qualification, experience and training,
- have knowledge about the applicable standards, provisions, accident prevention regulations and operating conditions,
- are in the position to carry out the required activities and thereby, to detect possible hazards and avoid accidents,
- undertake to immediately report any modifications to the device that might affect its safety,
- are familiar with the device, its function and possible sources of danger,
- have knowledge about the maintenance and repair of the device and
- have been expressly authorised by BAUR to open the device and make modifications to it.

12.2 Error messages

When an error message appears, proceed as follows:

1. Check the power supply and the connection and earth cables.
2. Note down the error text and the procedure that caused the fault occurrence.
3. Contact the BAUR representative.

12.3 Error codes

Co- de	Type of error	Solution
1001	High voltage error	Restart device
1001	High voltage error	Restart device
1005	Internal USB error	Restart device
1005	Internal USB error	Restart device
1006	Internal EEPROM error	Restart device
1006	Internal EEPROM error	Restart device
1007	Real-time clock error	Set date/time and restart device
1007	Real-time clock error	Set date/time and restart device
1008	Memory error	Restart device
1008	Memory error	Restart device
1009	Emergency-Stop active	Deactivate emergency-stop
1009	Emergency-Stop active	Deactivate emergency-stop
1010	Memory error	Restart device
1011	Digital-Analogue conversion error	Restart device
1011	Memory error	Restart device
1012	Internal EEPROM error	Restart device
1012	Internal EEPROM error	Restart device
1013	No calibration data	Prepare calibration data
1014	Invalid calibration data	Prepare valid calibration data
1015	Overvoltage	Restart device
2001	Communication errors in digital measuring bridge	Restart device
2001	Communication errors in digital measuring bridge	Restart device
2002	Timeout of digital measuring bridge	Restart device
2002	Timeout of digital measuring bridge	Restart device
2003	Command error in digital measuring bridge	Restart device

2003	Command error in digital measuring bridge	Restart device
2004	Digital measuring bridge not ready	Restart device
2004	Digital measuring bridge not ready	Restart device
2005	Self-test error in digital measuring bridge	Restart device
2005	Self-test error in digital measuring bridge	Restart device
2006	Zero balance error in digital measuring bridge	Check test lead connections
2006	Zero balance error in digital measuring bridge	Check test lead connections
2007	Communication errors in digital measuring bridge	Restart device
2008	Communication errors in digital measuring bridge	Restart device
2009	Communication errors in digital measuring bridge	Restart device
2010	Communication errors in digital measuring bridge	Restart device
2011	Communication errors in digital measuring bridge	Restart device
2012	Communication errors in digital measuring bridge	Restart device
2013	Communication errors in digital measuring bridge	Restart device
3002	Balance potentiometer at lower end	Check test lead connections and restart measurement
3003	Balance potentiometer at upper end	Check test lead connections and restart measurement
3004	Timeout during balancing	Check test lead connections and restart measurement
3005	Polarity change	Check test lead connections and restart measurement
3006	No fine balance possible	Check test lead connections and restart measurement
4001	Power-Module-Fault	Restart device
4002	Power-Module-Fault	Restart device
4003	Power-Module-Fault	Restart device
4004	Power-Module-Fault	Restart device
4005	Power-Module-Fault	Restart device
4006	Digital-Analogue converter error	Restart device
4007	Power-Module-Communication error	Restart device
4008	Power-Module-Communication error	Restart device
4009	Power-Module-Communication error	Restart device
4010	Power-Module-Communication error	Restart device

4012	Power-Module-Communication error	Restart device
4014	Power-Module-Excess temperature	Allow device to cool and restart
4021	Power-Module-Communication error	Restart device
4022	Power-Module-Error, error when setting the digital-analogue converter	Restart device
4023	Power-Module-Error, error when reading the analogue-digital converter	Restart device
9002	Balance potentiometer at lower end	Check test lead connections
9003	Balance potentiometer at upper end	Check test lead connections
9004	Timeout during balancing	Check test lead connections
9005	Polarity change	Check test lead connections
9006	No fine balance possible	Check test lead connections

On repeated occurrence of an error message, please contact BAUR Prüf- und Messtechnik GmbH or the BAUR representative.

12.4 Cleaning

- Clean displays only with a dry and slightly damp cloth.
- Use gentle cleaning agents for the housing.
- Protect the operating parts during storage.



Danger: Damaged devices can be dangerous for the user!

Solution: Do not use abrasive cleaning agents, chemicals or benzene. Do not allow liquids to go into the device!

13 DELIVERY INCLUDES



Replacement parts.....	51
------------------------	----

Delivery includes

- High voltage connection cable
- 4-wire bridge connection cable
- Connection clamps
- Short-circuit cable sets for bridge connection
- Grounding
- Mains cable
- USB stick
- Carrying sling
- User manual

Options

Necessary for cable sheath fault pin-pointing with step voltage method:

- Search receiver KMF 1 inclusive of ground rod and connection cables
- or
- Accessory set for cable sheath fault pin-pointing including ground rod and connection cables (if UL 30 available)

Other options

- Discharge and earth rod EES 40

13.1 Replacement parts

- Earth line (460-741)
- Mains cable
- Connection terminals (551-133)
- USB stick (310-078)
- Carrying sling (670-071)
- Short-circuit cable with clips (460-745)

14 DECLARATION OF CONFORMITY

Under sole responsibility, we



BAUR Prüf- und Messtechnik GmbH
Raiffeisenstrasse 8
A-6832 Sulz / Austria
headoffice@baur.at
www.baur.at

declare that the product

BAUR Cable sheath testing and fault location system shirla

conforms to whatever this declaration refers with the following standards or normative documents:

- Low voltage guideline 2006/95/EG
- EN 61010-1; VDE 0411-1:2002-08
- EN 50191; VDE 0104:2001-01
- EMC Guideline 2004/104/EG
- EN61000-4-4:2004
- EN 61000-4-2:1995 + A1:1998 + A2:2001
- EN 61000-4-2:1995 + A1:1998 + A2:2001
- EN 55011:1998 + A1:1999 + A2:2002



Gerd Kupper
(CEO)

Sulz, Austria, 14.04.2008

15 INDEX

A

Adding sections - 38

B

Bridge measurement in accordance with
Glaser - 9

Bridge measurement in accordance with
Murray - 11

C

Cable and cable sheath fault pin-pointing - 5

Cable and cable sheath fault prelocation - 4

Cable and cable sheath testing - 4, 32

Carrying out the tests - 34

Cleaning - 50

Commissioning - 24

Comparison of the voltage drop method and
bridge measurement - 20

Connecting the ground line - 23

Connecting the high voltage feed cable for
testing - 26

Connecting the protective ground cable - 26

Connecting to various cable types - 26

Connections and settings - 42

Connections for bridge measurement - 27

D

Declaration of conformity - 52

Delivery includes - 51

Discharging and earthing - 24

E

Ending a test early - 35

Ending measurement early - 41, 44

Error codes - 48

Error messages - 48

Example - 17

F

Fault location on a cable with branch joint - 14

Fault pin-pointing - 42

Fault prelocation / measuring bridge - 36

Features - 6

G

General - 3

I

Important basic rules - 24

M

Maintenance - 47

Measurement principle and accuracy - 7

Measuring error - 19

O

Operating controls - 22

Operating modes - 6

Operating the menu - 23

Operating unit - 22

P

Plastic cable N2XSY with a copper screen - 20

Preamble - 3

Preparing the cable - 25

Preparing the device for cable or cable sheath
testing - 25

Principle of the Wheatstone circuit - 7

R

Repeating measurements - 41

Replacement parts - 51

S

Safety features - 6

Sections - 37

Service personnel - 47

Settings - 33, 36

Shielded low voltage cable with a large cross-section - 21

Switching high voltage on and off - 30

T

Technical data - 46

U

Unknown distance to branch joint - 18

Updating software - 45

Use - 4

Using the menu - 29

V

Voltage and current display - 23

W

With one auxiliary line and different core cross-sections - 13

With one auxiliary lines and constant core cross-section - 13

With two auxiliary lines and constant line cross-section - 9

With two auxiliary lines and non-constant core cross-section or different specific resistances of the line material - 11

Working with only one section - 38

Z

Zero balancing - 39



BAUR Prüf- und Messtechnik GmbH
Raiffeisenstrasse 8
A-6832 Sulz / Austria
headoffice@baur.at
www.baur.at

822-127-2-vkl-28.04.2009

fw 0.7.0