

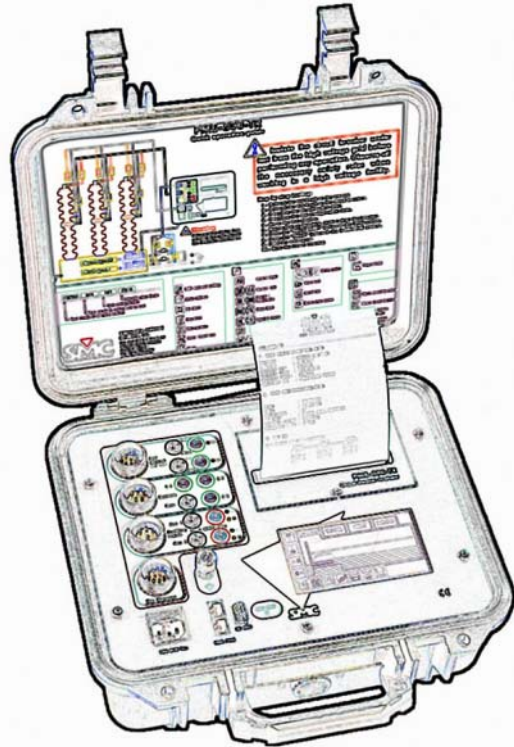

## Three-phase High- and Medium-voltage Circuit Breaker Analyzer

### User's Manual



# PME-500-TR

EDITION: July 7<sup>th</sup>, 2008

VERSION: 7



PME-500-TR

Quality is the core reference for EuroSMC's activities, aimed to fully satisfy our customers' needs and expectations.

#### DISCLAIMER

**The information, product specifications, and technical data contained in this document imply no contractual binding to EuroSMC's responsibility. The user is the sole responsible for the application of the products mentioned in this document. EuroSMC explicitly exonerates itself from liability to accidents or unwanted results, directly or indirectly derived from mistakes made in the writing of this document. Copying or reproducing all or part of this document is not allowed without the explicit written permission from EuroSMC. Due to continuing development and quality improvements, EuroSMC reserves the right to make changes in their products without notice.**

---

**CONTENTS**

---

<b>INTRODUCTION .....</b>	<b>5</b>
<b>PME-500-TR PACKING LIST .....</b>	<b>6</b>
<b>CONNECTING THE PME-500-TR TO THE BREAKER .....</b>	<b>7</b>
Wiring the <i>Coil Control</i> circuits.....	7
Protecting the breaker's coils.....	8
Wiring <i>Main Contacts</i> .....	8
Using the <i>Auxiliary Inputs</i> .....	8
<i>Res. Measure Connector</i> .....	9
<b>TOUCH SCREEN BUTTONS.....</b>	<b>9</b>
<b>MODIFYING DATA FIELDS.....</b>	<b>12</b>
Touch Keyboard .....	12
<b>INITIAL EQUIPMENT SETUP .....</b>	<b>13</b>
<b>BREAKER IDENTIFICATION DATA .....</b>	<b>13</b>
<b>TEST SETUP .....</b>	<b>13</b>
<b>TEST EXECUTION .....</b>	<b>15</b>
Time & Coil Current Analysis .....	15
Contact Resistance Measurement.....	17
<b>ERROR AND STATUS MESSAGES .....</b>	<b>17</b>
<b>TEST RESULTS .....</b>	<b>18</b>
On-screen viewing .....	19
Printing the test report .....	19
Storage and retrieval of tests.....	19
<b>USING THE PC SOFTWARE .....</b>	<b>20</b>

<b>PC connection .....</b>	<b>20</b>
<b>Using EuroBREAKER™ .....</b>	<b>21</b>
<b>THE RECHARGEABLE BATTERY .....</b>	<b>21</b>
<b>LOADING PRINTER PAPER.....</b>	<b>22</b>
Manual feed: .....	22
Automatic feed: .....	22
<b>TECHNICAL CHARACTERISTICS .....</b>	<b>24</b>
<b>BASIC TROUBLESHOOTING .....</b>	<b>27</b>
<b>PHYSICAL EQUIPMENT OVERVIEW .....</b>	<b>27</b>
The front panel .....	27
Accessing the internal assembly .....	27
Internal fuses .....	29
<b>PROBLEMS, CAUSES AND SOLUTIONS .....</b>	<b>30</b>
<b>TROUBLESHOOTING PROCEDURES .....</b>	<b>32</b>
1. Display Contrast RESET .....	32
2. Adjusting the Display Contrast.....	32
3. RESETing the Microprocessor .....	33
4. CLOSE & TRIP Command Duration.....	33
5. Resetting the recharge controller.....	34
<b>AFTER-SALES SERVICE AND WARRANTY .....</b>	<b>36</b>
<b>WARRANTY .....</b>	<b>36</b>
<b>CUSTOMER SUPPORT .....</b>	<b>36</b>
<b>OTHER EUROS MC PRODUCTS .....</b>	<b>36</b>

## Introduction

The PME-500-TR circuit breaker analyzer has been designed to simplify tests of contact synchronism, coil current analysis and contact resistance measurement on medium voltage circuit breakers, or in any case, on circuit breakers with a single contact per pole. Its use for circuit breakers with multiple contacts per pole is not advised, although this might occasionally be done by means of a more laborious process.

The use of the touch screen panel makes operation of the unit and data entry processes easier and more intuitive.

The multi-pole connecting blocks have been duplicated with standard banana-type connectors in case any of the multi-wire test leads are accidentally damaged, lost or made unavailable in any way.

The internal battery supply makes the equipment independent from the low voltage AC supply, not always available or close enough to the place of operation.

The contact resistance measurement is performed on the three poles at a time using the four-wire method and with an outstanding resolution of 0.1 micro-ohms under a measurement current of 10 A.

Please read this operation manual before using the PME-500-TR for the first time. The support team at EuroSMC will be very pleased to answer your questions if any arise. Congratulations for your good choice and thank you for considering EuroSMC products and services.

EUROSMC, S.A.

Pol. Ind. P-29 Calle Buril, 69

28400 Collado Villalba

MADRID (SPAIN)

TEL: 34-91-849.89.80 / FAX: 34-91-851.25.53

sales@eurosmc.com

<http://www.eurosmc.com>

## PME-500-TR packing list

1 PME-500-TR unit
1 Calibration certificate
1 Warranty statement and registration form
1 User's Manual
1 2.5 m AC supply cord
1 trip/close coil control and current measurement test lead 5-meter
1 auxiliary inputs test lead 5-meter
1 three-phase main contact test lead 5-meter
1 three-phase resistance measurement test lead 5-meter
1 set of spare fuses
1 pair of overvoltage protective diodes
1 set of crocodile-type clamps
1 spare thermal paper roll
1 RS-232 cable for PC connection
1 EuroBreaker™ program for Windows
1 Lightweight nylon bag for protection and transport

## Connecting the PME-500-TR to the breaker

The PME-500-TR connects to the circuit breaker under test by means of four multi-pole connectors. The first three (Coil Control, Main Contacts and Auxiliary Inputs) are duplicated with equivalent banana-type connectors in case any of the supplied multi-wire leads is lost or damaged. Once you have the instrument correctly wired to the breaker, the rest of the job is greatly simplified. A brief description of these connections follows.

### Wiring the Coil Control circuits



**WARNING! Auxiliary voltage inside a circuit breaker can reach 250 Vdc. Be sure that auxiliary supply is disconnected before manipulating the operation coil circuits of the breaker.**

This is the most controversial point of connection for new users. The key to proper cabling is understanding that two internal solid-state PME-500-TR's contactors are supposed to control (rather than to provide) the DC supply circuits of both (Trip and Close) coils of the breaker. Hence, these contactors must be connected **in series** with their corresponding coils and **polarity must be respected**. Look at the diagram in the instrument's lid. If you are breaking at the positive side of the breaker's coils, then connect each black **T** or **C** lead to its corresponding coil and the blue leads to a point coming from the positive side of the DC supply. Use the opposite color scheme if you are breaking at the negative side of the coils. This setup will give TRIP/CLOSE control to the PME-500-TR for easier, faster and more accurate testing.

The multi-pole connector is duplicated so that standard bananas can be used instead (black corresponds to negative and green to positive).



**DC Polarity to the breaker's coils must be respected in this cabling procedure or the control actions from the PME-500-TR will not be performed at all.**

Red LED indicators will be lit instantaneously whenever the PME-500-TR completes the circuits into which these contacts are inserted.

### Protecting the breaker's coils

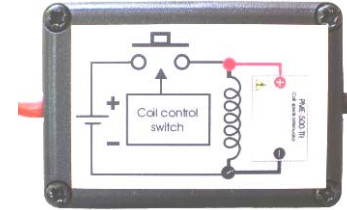

Connect the supplied overvoltage protection diodes in parallel to the trip and close coils following their polarity. This will prevent the coils from overheating if a wrong connection to the PME-500-TR is made or if the auxiliary contacts in charge of disconnecting the coils from the DC supply do not work correctly.

### Wiring Main Contacts

The breaker's main contacts are wired to the PME-500-TR through this connector. Attach the red "C" terminals to one side of the poles and the black ones to the other side. Use order 1, 2 and 3 and colors consistently at each pole. If you use the duplicate 4-mm connectors, you will have to bridge one side of the three poles to make a common point and connect it to the "Com." connector.

**IMPORTANT NOTICE: WITH GROUNDED BREAKERS – Time and resistance tests are not possible while both sides of the breaker are connected to ground. You can keep only one side connected to ground as long as you use the black banana terminals to the poles on that side, and the red ones to the free poles.**

For timing tests, the PME-500-TR injects a low (100 mA) current through the breaker's poles using these leads, in order to detect and record changes in the contact status.

For resistance measurement, a 10 A test current is injected using these wires, and the voltage drop is measured at the terminals of the contact resistance connector (described later in this section) that should also be wired to the poles for this purpose.



**If you accidentally apply any significant voltage to these leads, one or more internal fuses might be blown. Should this occur, refer to the troubleshooting section at the end of this manual for instructions on fuse replacement.**

### Using the Auxiliary Inputs

These additional input channels can be used independently for two different purposes:

- 1) Analyzing the open/close activity of any two contacts inside or related to the circuit breaker during with the timing test.
- 2) Detecting contact or voltage changes at any two points inside or related to the breaker to start the timer and the data recording process. This is called 'trigger event' detection, described in the test setup section.

These inputs are fully isolated from each other and from the earth of the equipment and have no polarity. Two pairs of LEDs next to the duplicate 4-mm connectors indicate the mode (dry contact or voltage detection) to which these inputs have been set up as later described in the Test Menu section. Protection against accidental overvoltage (above 400 V) is provided for these inputs by means of internal fuses. Refer to the troubleshooting section at the end of this manual for instructions on locating and replacing these fuses.

The auxiliary inputs are commonly used to analyze the breaker's coil contacts timing with relationship to the main contacts, but it is also frequent to connect them to some other points inside the breaker or affected by its operation, like auxiliary contacts or monitoring points, also for time analysis purposes. However, using these inputs as test initiators is also a powerful technique when, for example, you cannot drive the breaker from the PTE-500-TR or you want to refer the time analysis to an electrical event other than the START command in the instrument. This technique is further described in the *Test Execution* section.

### **Res. Measure Connector**









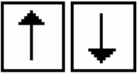

As explained before, when resistance measurement is conducted, a 10 A test current is injected through the main contact connector's leads and the voltage drop at the contacts is measured by the leads in this connector.

***IMPORTANT NOTICE: WITH GROUNDED BREAKERS – Time and resistance tests are not possible while both sides of the breaker are connected to ground. You can keep only one side connected to ground as long as you use the black banana terminals to the poles on that side, and the red ones to the free poles.***

This 4-wire method provides adequate accuracy as long as connections are made firmly and in the correct order, which is the pole's contact inside the *Res. Measure* points and all this inside the *Contacts* connections. Phase order (1, 2, 3) and polarity (Red, Black) must also be consistent between the Main Contact lead set and the Resistance Measurement terminal set. If you connect the main *Contacts* leads in between the *Res. Measure* leads, you will get a wrong, useless resistance value because this will include the resistance of the *Contacts* test leads' connections.

### **Touch Screen Buttons**

All the operation of the PME-500-TR is carried out by means of the ON/OFF switch and the touch screen buttons in the LCD panel. A description of these buttons follows.

	The <b>ON/OFF switch</b> serves two purposes: 1) turning the unit ON or OFF when held down for a few seconds, and 2) turning the LCD backlight on and off with a short press.
	<b>LCD contrast adjustment.</b> Press and hold to increase the contrast. Release, then press and hold to decrease... and so on.
	<b>Up and Down</b> cursor arrows allow navigation through data fields, parameter values and menu choices.
	<b>Edit Button.</b> Touch it to modify selected data fields or parameter choices.
	<b>Enter Button.</b> Touch it to confirm the setting of a parameter or a selection from a menu.
	<b>Test memory cleanup.</b> Press and hold this button to fully delete the test identification, test setup and temporary results in memory. Test setup parameters will revert to factory default settings.
	<b>New test.</b> Similar to the previous button, but only the results of the latest test will be cleared from memory. Identification data and test setup parameters will not be deleted. You don't need to use this button before every new test, because temporary test memory is automatically overwritten by new results.
	<b>Test Menu.</b> Once the identification data and test setup have been fulfilled, touch this button to jump into the test execution screen.
	<b>Test Storage.</b> Touch this button to jump into the test storage screen in order to store the test in non-volatile memory or to retrieve a previously stored test.
	<b>Retrieve test.</b> Load a previously saved test. This will overwrite the temporary test memory (identification data, setup parameters and results of the last test performed).

	<b>Save test.</b> Touch this button to store the contents of the temporary test memory into one of the three sectors available in the non-volatile storage area.
	<b>Print Menu.</b> Touch this button to jump into the report-printing submenu, from where you can print the report and feed the paper.
	<b>Paper feed.</b> Press repeatedly to feed paper in small amounts or hold down for continuous feed.
	<b>Exit.</b> Touch to exit the current menu.
	<b>TRIP command.</b> Touch to issue an OPEN command of the specified duration to the circuit breaker.
	<b>CLOSE command.</b> Touch to issue a CLOSE command of the specified duration to the circuit breaker.
 	<b>Aux 1/2 sense mode.</b> Touch to toggle the detection mode of Auxiliary inputs #1 or #2. Successive presses will cycle from Dry Contact to Low Voltage (1.5 to 15 V) to High Voltage (15 to 400 V) detection modes.
	<b>Timing Test.</b> Touch to initiate the programmed sequence. The unit will first clear its memory and reset its internal counters. If Trigger parameter has been set to other than Operation, the unit will wait for the specified trigger event to take place. If you touch the button again now, the test will be cancelled.
	<b>Contact Resistance Measurement.</b> Place the breaker in closed position and touch this button to perform the contact resistance measurement.

## Modifying Data Fields

There are basically two types of data fields in the various setup areas of the PME-500-TR: Selectable options and free-text fields. Setting options like Open/Close sequences or possible Debounce values generally require getting into the appropriate menu, highlighting a field, touching the Edit button, scrolling over a set of possible choices and confirming the highlighted value with the Enter button:



Free-text fields are entered and modified with the Touch Keyboard.

## Touch Keyboard

When you highlight a text field and touch the Edit button, the Touch Keyboard will automatically be displayed with the field contents at the bottom. Imagine this as an upside-down typewriter.

You can now add, delete or insert text characters, and touch the Exit button when you are done.

Some buttons and combinations, apart from the actual character set, are provided by the Touch Keyboard to simplify the editing process:

Access to an extended set of symbols and special characters not included in the basic QWERTY layout. The keyboard will revert to the regular layout automatically after typing one of these characters.

Store the present field and put the next field in the menu into the edition line. This shortcut saves time when more than one field from a menu (for example, in the Test Identification Data screen) are to be entered or modified.

Switch between *insertion* and *overwriting* modes. The shape of the cursor will change accordingly.

Move the cursor to the right.

Move the cursor to the left.



Store the edited field and exit the Touch Keyboard.

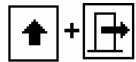

Exit the Touch Keyboard without saving the changes made.



Delete the character to the right of the cursor.

The edition space of these fields is limited to a maximum of 51 characters. This length may only be displayed when the edition menu is entered, as the space available in the DATA file cannot fit the whole length.

## Initial Equipment Setup

The initial setup menu is accessed by pressing both upper corners of the LCD panel simultaneously. The following setup fields can be changed:

**DATE and TIME:** Essential for adequate identification and retrieval of printed and saved tests.

**LANGUAGE:** Select your preferred operation language here.

**COMPANY and CONTACT:** Enter the name of your company and the name of a relevant contact person here.

These fields will be printed in the header section of every report.

## Breaker Identification Data

Access this data menu by touching the DATA tab. The following fields are provided to describe and identify the tested breaker immediately after the header section of the test report: *Station Name, Circuit Name, Breaker's Reference, Breaker's Manufacturer, Breaker's Model and Operator's ID.*

Highlight a field and touch the Edit button to enter or modify it.

## Test Setup

Touch the SET tab to access this menu. Test sequence, operation parameters for the breaker and other important setting are defined here:

**OPERATION:** Select the automatic operation sequence to be carried out and analyzed on the breaker. Six possible sequences are available: open (O), close (C), open – close

(O-C), close – open (C-O), open – close – open (O-C-O) and close – open – close (C-O-C). Touch the Edit button, highlight a choice using the UP and DOWN arrows and confirm with Enter.

**DURATION:** Trip and Close command duration, as well as pause length between two consecutive commands are specified here in 10-ms increments. The specified command duration will be interrupted and the next pause executed as soon as at least one of the main contacts completes de command.

**TRIGGER:** When you press the START/STOP button to perform a test, the PME-500-TR will wait for the 'Trigger event' to occur before starting the internal timer and the recording of the changes in the breaker's contacts. The following choices are available:

- **OPERATION:** Data recording starts immediately upon execution of the first programmed command (Open or Close) after the START/STOP button is pressed in the TEST menu. This is the most commonly used trigger event when the breaker's coil DC supply circuits can be set under the control of the PME-500-TR.
- **AUX1(ON) or AUX2(ON):** After pressing the START/STOP button, the unit will stay on hold until a voltage appears or a contact is closed at the selected auxiliary input.
- **AUX1(OFF), AUX2(OFF):** After pressing the START/STOP button, the unit will stay on hold until any present voltage disappears or the contact is opened at the selected auxiliary input.

Auxiliary input events are used when the breaker cannot be controlled from the PME-500-TR for any reason or simply when the user wants the recorded times to be referenced to an electrical change different from the sending of the first TRIP or CLOSE command.

- **DELAYED:** Use this option to analyze switchgear that takes more than 2 s. to complete a maneuver, such as a closing interrupter/breaker combination. After the first command has been issued to the coil, the data recording can be delayed until –
  - A change is detected at any main contact ("MAIN CNT")
  - A change is detected at any auxiliary contact ("AUX CNT")
  - A change is detected at any contact ("ANY CNT")
  - The time specified in the TRIG. DELAY parameter (see below) is elapsed ("TIME")

**NOTE: Maximum delay is 18 seconds, regardless the option selected**

**REC. LEN:** The graphics window's size in milliseconds is stored here. The smaller the size (shorter time), the higher the detail, or ZOOM effect of the printed graphics will be. Graphics representation aperture can be selected among 200, 400, 800, 1600 and 2,000 ms. This field can be modified after the test is done to re-print the report for a better fit as many times as desired. However, once the test is saved into non-volatile memory, the recorded data will be truncated to the specified length permanently.

**DEBOUNCE T:** This field specifies the minimum duration for which any recorded state (closed, open or pre-insertion) must be held in order to be included in the contact times listing. This filter prevents the timings print area to overflow and can be chosen among 0, 0.5, 1 and 2 ms. Debounce will not affect the graphic representation of the contacts' states.

**TRIG. DELAY:** If you selected DELAYED ... TIME at the *Trigger* menu, you can specify the wait time here, up to 18.0 s. in 0.1 sec. increments.

## Test Execution

### Time & Coil Current Analysis

This process consists basically of recording what happens inside the breaker in terms of –

- Changes in main contacts' state
- Changes at auxiliary inputs.
- Evolution of DC current in the operation coils.

The recording duration is 2 seconds, and the above changes are detected and time-stamped at 10 kHz (10,000 samples per second) resolution for timing and 1 kHz for currents. This duration spans well beyond the TRIP-CLOSE-TRIP sequence of any breaker.



**Warn surrounding people nearby before actuating a medium- or high-voltage circuit breaker.**

Once the PME-500-TR is correctly wired to the breaker and the test conditions are set as explained above, the test procedure is reduced to a few simple steps:

- 1) Open the TEST screen by touching the  button.
- 2) Touch the  button.

During the first 1 -1 ½ seconds the unit will clear the sampling memory, will check the breaker's contact positions and will reset the internal counters. This short delay makes new

users think that they have not touched well and usually retry, sometimes causing the process to be cancelled.



Once the PME-500-TR has completed this short *warm-up* process, one of the following will occur:

- a) If *OPERATION* was selected as the **Trigger** Event in the Test Setup menu, the programmed sequence will be issued to the breaker, the timer will start and the recording of data will take place immediately.
- b) If you selected any of the AUXiliary inputs as the trigger event, the process will stay on hold until the specified event takes place at the chosen input. The message **Status: Waiting Trigger** will be displayed at this time. If you press the START/STOP button again now, the process will be cancelled and the message **Status: Test Aborted** will be displayed. When the expected event is detected, the test is initiated.
- c) If you selected the *DELAYED* option, the programmed sequence will be issued but no time data will be recorded before the selected contact activity is detected, or the specified wait time has elapsed, or 18 seconds later, whichever occurs first.



In any of the above cases, the system's timer will start exactly when the first programmed command (Trip or Close) in the test sequence is issued to the breaker. If contacts at the end of the test are in the expected position, the message **Status: Test Done** will be displayed. Otherwise, **Status: Error During Test** will be displayed instead, so you can check your connections and settings and try again.

If you have programmed the test sequence to begin with a TRIP operation, ensure that the breaker is previously placed in its closed position. Reversely, if you are starting with a CLOSE operation, place the breaker in its open position first. Otherwise, a **Status: Switch Incorrect** message will be displayed when the test is attempted. If you have wired the PME-500-TR's coil control terminals to the working control circuits of the breaker, you can issue manual Trip or Close commands to the breaker by touching the



TRIP  or CLOSE  buttons at the bottom of this screen accordingly. No recording will result from the use of these buttons.



Also at the bottom of this window, buttons  and  are found. If you are using the auxiliary inputs to detect the Trigger event, you must set the detection mode according to the type of signal expected in that input. Press the corresponding button repeatedly to cycle through Dry Contact, Low Voltage (1.5 to 15 V) and High Voltage ((15 to 400 V) modes while you observe the status LEDs next to the duplicate Aux.1 or Aux.2 connectors.

## Contact Resistance Measurement

Contact resistance measurement is a separate process that you can carry out whenever the breaker is closed. Also, the appropriate test leads must be in place, naturally. Refer to the connection instructions at the beginning of this manual for details on proper cabling.



**If the breaker is not closed or not properly connected to the PME-500-TR, or if the built-in battery is exhausted, you will get a measurement error message, rather than an erroneous resistance value.**

Refer to the troubleshooting section at the end of this manual if you experience contact resistance measurement problems.

## Error and Status Messages

When you first enter the TEST window, the status line displays the present detection mode of the Auxiliary inputs #1 and #2 with any of the following messages:

**Aux1/2,Volt Mode,Hi:** Auxiliary input 1/2 set for high voltage ( $\pm 15$  Vdc).

**Aux1/2,Volt Mode,Lo:** Auxiliary input 1/2 set up in low voltage ( $\pm 1.5$  Vdc).

**Aux1,Contact Mode:** Auxiliary monitor 1 set up in contact mode.

**Aux2,Contact Mode:** Auxiliary monitor 2 set up in contact mode.

Following is a list of possible test-related messages:

**Error During Test:** An error has occurred during the test. Repeat the test.

**Switch Incorrect:** The initial position of the main contacts make the first test command execution impossible.

**Test In Progress:** This message is displayed during the execution of the operation sequence.

**Test Done:** Test successfully completed (this does not mean a good breaker's condition).

**Test Aborted:** The user has pressed the START/STOP button a second time.

**Switch Close:** Circuit breaker closed.

**Switch Open:** Circuit breaker open

**Waiting Trigger:** Waiting for the specified trigger event to occur at the selected auxiliary input.

**Switch Cooling:** Equipment's Internal switchgear is cooling down (test temporarily not allowed).

**Switch Open Ovld:** When current through the trip coil control circuit reaches 53 Adc a protective mechanism will automatically cut off.

**Switch Close Ovld:** When current through the close coil control circuit reaches 53 Adc a protective mechanism will automatically cut off.

**Aux1 Overload:** Auxiliary input will switch to voltage mode whenever any significant voltage is detected.

**Aux2 Overload:** Auxiliary input will switch to voltage mode whenever any significant voltage is detected.

## Test Results

Test results are displayed and printed in graphical and alphanumeric representation. Numerical data include peak current measured at both coils, chronological list of position changes in main and auxiliary inputs and the contact resistance values for the three poles if measured. If you have selected the DELAYED option in the Trigger menu, the event that determines the beginning of the data capture or the TRIG. DELAY time value will also be displayed. Chronographic drawing of contact changes and coil current evolution compose the graphic section of the test results.



**Total elapsed time values, rather than partial times, are displayed in the results report. Time origin is when first command in the programmed sequence is issued to the corresponding coil.**

The printed version of the graphics area shows the chronological evolution of operation coils currents in a separate time/current grid, and a 5-stroke contact chronogram at the bottom. A solid black stroke indicates CLOSED contact. For main (1, 2 and 3) contacts, an intermediate, half-width stroke indicates the actuation of pre-insertion resistors:

	Open ("O" prefix in time stamps)
	Closed ("C" prefix in time stamps)
	Pre-insertion ("R" prefix in time stamps)

For auxiliary inputs only full and empty strokes are used, which corresponds to closed contact / voltage on and open contact / voltage off, depending on the detection mode used.

The printed report includes a header with date, breaker's identification, test setup parameters and graphics scale.



## On-screen viewing

When you exit the TEST screen or retrieve a stored test from non-volatile memory, a low-resolution graphical representation of the test results is displayed in the GRAPH window. This allows you to check for successful completion of the test at a glance. Then, touch the RES tab to open the numerical results window and use the UP and DOWN arrow buttons to pan through the contact timing, contact resistance (if measured) and coil current results.

You can now make cabling and/or setup corrections and repeat the test if necessary, or save and/or print the test report.

## Printing the test report





Touch the  button in the PRINT menu to print the test Report. Before tearing the paper band off, feed an additional inch of paper using the  button.



**Thermal paper image will quickly fade when exposed to daylight. Split the report in two halves and make a photocopy of both sections if you intend to use the printout for more than a few days.**

## Storage and retrieval of tests

It is highly recommended to save valid tests in the PME-500-TR non-volatile storage memory. A total of up to 60 tests can be distributed in three storage sectors ,  and . There is no difference between these sectors. They are provided to allow for some kind of organization or classification of the tests. Stored tests are kept in memory even if the internal battery of the unit is fully discharged.

Saved tests include results, settings and identification data, and can be later recalled to perform new tests in the same or similar breaker with little or not setup modification. For example, if breakers A, B and C or other similar to these are periodically tested, you can save their first results in sector 2. Next time you need to test again breaker B or a similar one, you recall the B test from sector 2, modify a few identification fields or setup parameters. If at all needed, execute the test and save it in sector 0, thus preserving the original 'B' results in sector 2.



**Save your test before doing a new test, retrieving a saved test or switching the unit off. Otherwise, the test results and setup data will be permanently lost.**



Touch the  button. A list with the contents of the last visited sector S0, S1 or S2 will be displayed, with the sector's memory usage value at the bottom, in percentage. You can now do the following:



Select a sector



Navigate the test list



Save the last test done into the selected sector



Retrieve the highlighted test from the list



Leave the memory menu

## Using the PC software

EuroBREAKER™ is a simple Windows-compatible utility included in the PME-500-TR's standard accessories that enables the following tasks:

- 1) Downloading saved tests from the PME-500-TR non-volatile memory sectors to the PC for viewing, printing, archiving, exporting, e-mailing etc.
- 2) Uploading archived tests in the PC to the non-volatile memory sectors of the PME-500-TR to re-utilize their setup and identification date for new tests.
- 3) Restoring or uploading new versions of the PME-500-TR firmware to its microprocessor's firmware memory.

## PC connection

- 1) Install the EuroBREAKER™ program in the PC and launch it. The PC must have an RS-232 port.
- 2) Connect the RS-232 port of the PME-500-TR to a free RS-232 port in the PC using the supplied communications cable and turn the PME-500-TR on. The message "On line" should be displayed at the lower left corner of the program's window within a few seconds. If it does not, click on *Configuration / Communications* and try writing a different COM number. If you are using a native, physical DB-9 format port, this number is usually 1, 2 or 3. If you are *converting* an USB port, for example, the number can be higher. To know what numbers have been assigned to your ports by Windows, use the Device Manager at My Computer's properties dialog.

## Using EuroBREAKER™

Once you have connected the PME-500-TR to your PC, you can

- **Download tests from the PME-500-TR.** Select the *Import Data From Equipment* option in the *File* menu. You download complete S0, S1 or S2 sectors, rather than individual tests.
- **View and print downloaded tests.** After clicking on the *Tests* menu, highlight and double-click one test in the list for viewing, then click on the PRINT button to send it to the Windows default printer.
- **Export to csv ('comma-separated values') format.** Highlight one test in the list and click on the *Export to .txt* button to create a text file with elementary data separated by commas. This file can be imported from popular analysis and reporting programs like Microsoft Excel® later on.
- **Save downloaded tests to a file in your hard disk.** Select the *Save Data File* option in the *File* menu. One file will be created containing all the tests from the downloaded sector, though selected tests can be deleted from the list before saving to a file.
- **Open test files from the hard disk.** Click *Open Data File* in the *File* menu and navigate to the appropriate folder. Open the desired file and click on the *Tests* option to view, print or delete tests from the test list.
- **Upload selected tests to a PME-500-TR's non-volatile memory sector.** Click on the *Send Data to Equipment* option in the *File* menu. Warning: this will delete the existing contents of the destination sector in the PME-500-TR.
- **Restore or update the PME-500-TR's firmware** with a firmware file previously saved in the PC's hard disk. Ask for new firmware versions to your EuroSMC sales representative. Click on the *Firmware Update* option in the *Configuration* menu and follow the firmware update wizard.



**Once the update procedure is started, the unit will wait for the required file to be uploaded indefinitely or until you reset the microprocessor (refer to the "Microprocessor Reset" procedure under the Basic Troubleshooting section).**

## The Rechargeable Battery

The PME-500-TR has a built-in 12 Vdc NiMh battery that automatically recharges itself whenever the unit is plugged into an AC supply. When the unit is switched off and plugged in, a battery icon will flash in the upper right corner of the LCD screen, with the present level of charge being indicated by a shadowed segment. While switched on, the

unit's batteries will also recharge at a slower pace and an AC plug icon will be displayed instead.



**If battery seems to get flat too early after charging the unit switched off for 4 hours, follow the procedure described in the Troubleshooting section.**

## Loading Printer Paper

The paper can be manually or automatically fed into the printer.

### Manual feed:

- 1) Unscrew the bolt using a 3 mm. *Allen* and open the printer's cover
- 2) Cut the paper edge as shown to make insertion easier.
- 3) Free the rubber roller up by lifting the blue lever at the right side.
- 4) Insert the edge and drag the roller manually to make it turn until the paper comes out towards you some 8 cm. Paper should come out the roll from below.
- 5) Press the blue lever back down to block the paper in position and pull gently towards you to check that it has no turn.
- 6) Drive the free length of paper through the slot in the printer's lid while you place it back into position and fasten the retaining screw with your fingers. Do it firmly but do not use a tool. In this way you'll be able to remove the screw back by hand again.

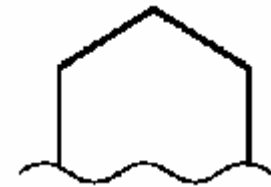

### Automatic feed:

- 1) Review the manual method above. Do not release the blue lever this time.
- 2) Cut the paper as shown below to make insertion easier.

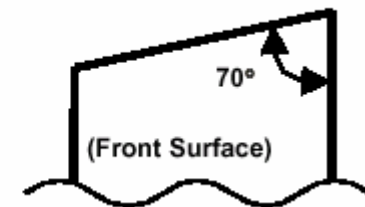
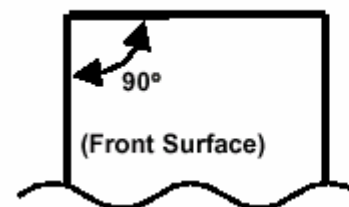

- 3) Upon inserting the paper as shown in the figure, the printer will automatically detect and wind the paper. If it does not, this means that it has not detected the presence of paper or the blue lever is released.
- 4) Once some 4" length has been brought through, release the blue lever and re-align it if needed.
- 5) Engage the lever back down and check for proper alignment by pulling the paper slowly towards you.
- 6) Drive the free length of paper through the slot in the printer's lid while you place it back into position and fasten the retaining screw with your fingers. Do it firmly but do not use a tool. In this way you'll be able to remove the screw back by hand again.

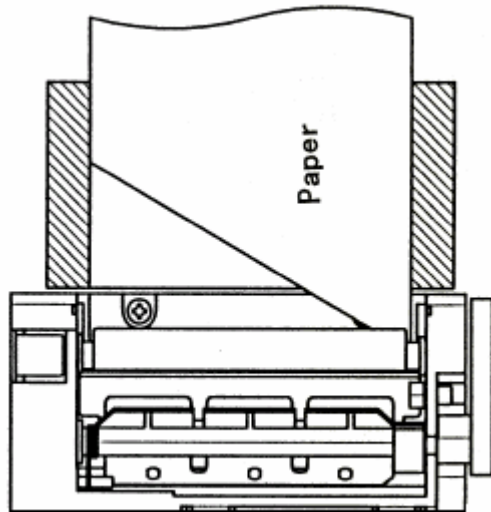

## Technical Characteristics

### INPUT SECTION

Main Contacts	
Number:	3 inputs + common (earth)
Open Circuit Voltage:	10 V Dc maximum
Test current	100 mA maximum
Detected States:	Closed (C) ( $r < 30 \Omega$ ) Pre-insertion (R) ( $30 \Omega < r < 10 \text{ k} \Omega$ ) Open (O) ( $r > 10 \text{ k} \Omega$ )
Auxiliary Inputs	
Number:	2 completely isolated binary inputs
Contact Mode	Open Circuit Voltage: 5 Vdc Test current: 20 mA maximum
Voltage Mode:	Range: From $\pm 1.5$ to $\pm 400$ Vdc Low activation range: $\pm 1.5$ to $\pm 15$ Vdc High activation range: $\pm 15$ to $\pm 400$ Vdc

## BREAKER OPERATION

Programmable sequences:	Close (C)
	Open (O)
	Close – Open (C – O)
	Open – Close (O – C)
	Close – Open – Close (C – O – C)
	Open – Close – Open (O – C – O)
<b>Time measurement start signal</b>	
Can be selected between:	Coil operation
	Auxiliary input 1 ON or OFF
	Auxiliary input 2 ON or OFF
	Position change at any contact input
	Delay up to 18.0 seconds
<b>Command Duration Settings</b>	
Close, Open, 1 <sup>st</sup> Interval, 2 <sup>nd</sup> Interval	10 to 2000 ms (in 10-ms steps)

## MEASUREMENT

<b>Time Measurement and Graphical Representation</b>	
Graphics window length:	Selectable between 100 ms, 200 ms, 400 ms, 800 ms, 1600 ms and 2000 ms
Time resolution:	± 0.1 ms (10 kHz sampling frequency)
Accuracy:	± 0.05 % ± 0.1 ms
Graphics resolution:	0.8 ms per mm

<b>Current Measurement and Graphical Representation:</b>	
Range:	0 – 50 A dc
Resolution:	0.1 A (1-kHz sampling frequency)
Accuracy:	1 % of range ± 100 mA
Graphics resolution:	Automatic scale up to 50 mA per vertical mm.
<b>Contact Resistance Measurement</b>	
Range:	Automatic range selection in decades from 100.0 μΩ to 1,000 μΩ
Resolution:	0.1 μΩ maximum
Accuracy:	± 1% of range ± 1 digit
Measurement current	10 A dc

## TOUCH SCREEN, KEYBOARD AND PRINTER

<b>Touch Screen</b>	
Type:	Transflective Graphical LCD
Dimensions:	113 x 61 cm.
Color:	Black & White
Lighting:	CCFL
<b>Built-in printer</b>	
Printing technology:	Thermal
Paper width:	Standard 110-mm wide continuous roll.
Maximum roll diameter	40 mm

## Basic Troubleshooting

Easy diagnostics and common self-assistance procedures are described here.

### **PHYSICAL EQUIPMENT OVERVIEW**

Basic troubleshooting can be conducted on the front panel and in the internal assembly.

#### ***The front panel***



#### ***Accessing the internal assembly***

Fuses and other connections are found here that could require basic service. No disassembly of these internal components should be ever required nor performed by the user for basic troubleshooting. For troublesome situations beyond those covered here, please contact always EuroSMC or your local dealer.

To access the internals of the instrument, you must first remove the front panel as described here:



1. Unscrew the 6 Allen bolts highlighted in the picture.



2. Grab the grounding connector and lift the front panel some 5 cm.



3. Undo the ribbon connection underneath the right edge of the front panel.



4. Turn the panel up over its right hand side and note the wire connections before undoing them.

**Internal fuses**

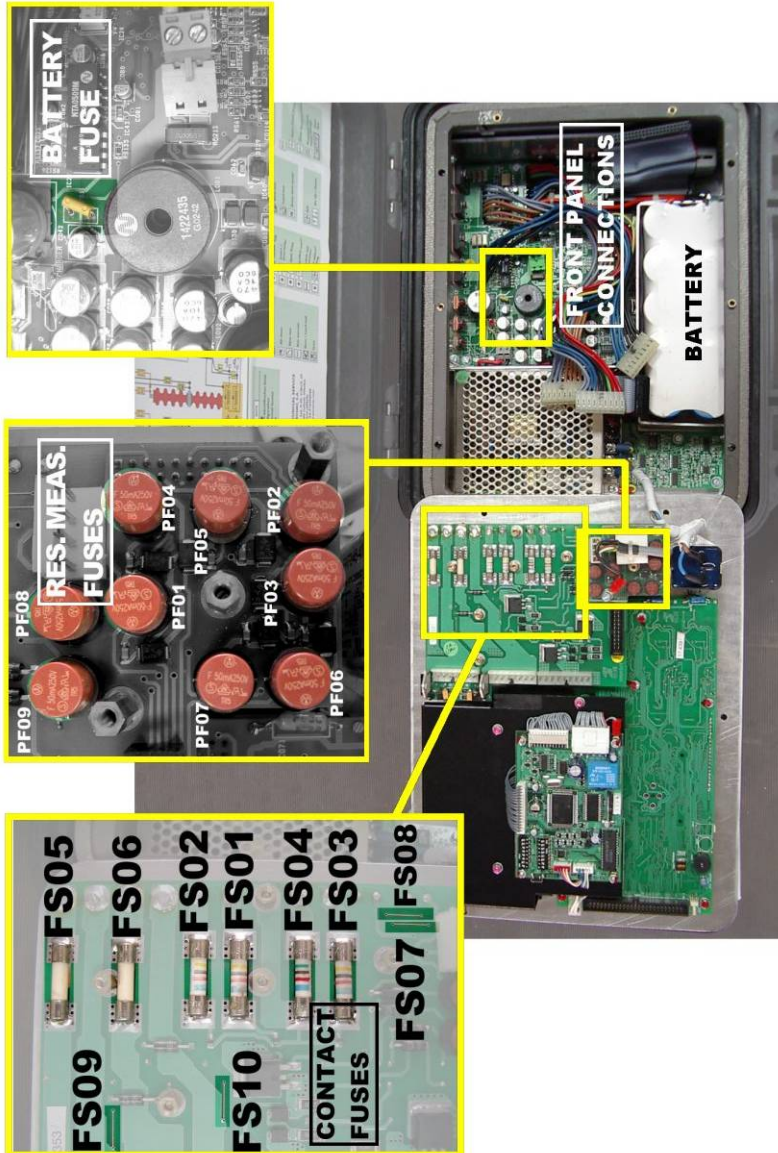

**PROBLEMS, CAUSES AND SOLUTIONS**

Symptom	Possible cause	Solution
The unit will not power up	Exhaust battery	Connect to a 100-240 VAC supply.
	Main supply fuses L or N possibly blown (see the diagram)	Replace the blown fuse(s)
Poor battery performance	Misadjusted level control	See procedure #5 below
The battery doesn't come to any charge	10 A battery fuse blown (see the diagram)	Replace the blown fuse(s)
Nothing is displayed	Contrast setting too low or too high	Reset and/or adjust the contrast (see procedures #1 and #2 below)
No response from the touch panel	Hang microprocessor	RESET (see procedure #3 below)
The unit cannot be switched off		
No printing	Loose data connection (see the diagram)	Reassure the ribbon connector
Close or open commands are not executed by the breaker	Command duration is set to zero or too short	Set a valid duration (see procedure #4 below)
	Blown + (FS05, FS06 – 20 A slow) or GROUND (FS09, FS10 BTF) close or trip fuses (see the diagram)	Replace the blown fuse(s) or repair (BTF)
"Switch incorrect" message upon start of test	Inconsistent initial breaker's position	Close or open to match the first command in sequence
	Both sides of breaker are grounded	Disconnect from ground the side with the black terminals

No time recordings for one or two breaker's main contacts	Channel protection fuses FS01, FS02 or FS03 (4 A slow) blown (see the diagram)	Replace the blown fuse(s)	
No time recordings for any main contacts	Common main contact fuses (FS04, 5 A slow) blown (see the diagram)	Replace the blown fuse(s)	
Resistance value too big	Dirty, defective or misaligned contacts	Submit the breaker to maintenance	
	"R" and "C" terminals in wrong position	Refer to the connections section	
No resistance measurement from one or two main contacts	~~~~ message displayed or printed	Unable to perform a reliable resistance reading	Check for loose connections
	Vsns? message displayed or printed	50 mA FAST fuses for channel 1 (PF01 or PF04), channel 2 (PF02, PF05) or channel 3 (PF03, PF06) (see the diagram)	Replace the blown fuse(s)
	R>>> message displayed or printed (Time will not be recorded either)	Channel protection fuses FS01, FS02 or FS03 (4 A slow) blown (see the diagram)	
No resistance measurement from any main contacts	Vsns? message displayed or printed	Common 50 mA FAST PF07 fuse blown (see the diagram)	Replace the blown fuse(s)
	R>>> message displayed or printed (Time will not be recorded either)	Common main contact fuses (FS04, 5 A slow) blown (see the diagram)	
AUX1 or AUX2 record no event	+ (PF08, PF09 – 50 mA FAST) or GROUND (FS07, FS08 BTF) aux input fuses (see the diagram)	Replace the blown fuse(s) or repair (BTF)	



**Check your cabling from the instrument to the circuit breaker and repeat the test before suspecting of a blown fuse. A bad or missing contact to a test point can produce the same symptoms as a blown fuse.**











**Use only fuses with the same rate and type as the ones replaced. Failure to do this may invalidate the warranty.**

## **TROUBLESHOOTING PROCEDURES**

### **1. Display Contrast RESET**

For an easier display contrast adjustment it is recommended to reset the factory contrast setting first. This procedure restores the "center" contrast position and then sets the maximum and minimum adjustable values to our preferences.

- 1) Press   simultaneously until you hear a short beep. The center contrast value has now been set.
- 2) Press **and hold**  until the desired *maximum* adjustable contrast is reached by the display.
- 3) Press  and  to store the maximum adjustable contrast value in memory. A short beep should be heard.
- 4) Again, press **and hold**  until the desired *minimum* adjustable contrast is reached by the display.
- 5) Press  and  to store the minimum adjustable contrast value in memory. A short beep should be heard.

### **2. Adjusting the Display Contrast**

Once the max and min contrast adjustment values have been set with the above procedure, you can easily regulate the display contrast between those limits to better adapt the readability of the display to the surrounding light conditions. Beware that the



adjustment direction toggles each time the  key is pressed. This means that you will not be able to effectively adjust the contrast with repetitive key presses. Instead, keep the key pressed while watching the display. To invert the adjustment direction, simply release and hold the key again until the desired contrast is attained.

### 3. RESEtting the Microprocessor



A 'hang' microprocessor will cause the unit not to respond to the touch panel nor to the ON/OFF switch. An internal RESET pushbutton is provided to recover the normal unit's operation. Do the following to access and use the RESET button:



- 1) Disconnect the unit from any external AC supply.
- 2) Remove the 6 4-mm Allen bolts that lock the front panel.
- 3) Grab the golden ground connector firmly and gently lift the front panel until a soft stop is reached. Slide now the panel a little bit to the right so it can be further lifted for a 3 to 4 mm aperture in the front edge. The 8-mm RESET button will then be visible upside-down underneath the panel.
- 4) Press the RESET button for a short while and rest the panel in place.
- 5) Check the unit for correct operation and lock the panel in place with the Allen bolts. Do not overtighten them.

### 4. CLOSE & TRIP Command Duration





The PME-500-TR's factory settings include zero (0 ms) duration for the trip and close command. This makes impossible to drive a circuit breaker's operating coils for testing and can lead to the erroneous conclusion that the unit is damaged or not working properly. Do the following to set valid command duration values:

- 1) Touch the SET tab to go into the Test Settings Menu.

- 2) Highlight the "Duration" tag using the arrow   keys and touch the MODIFY  key. The word EXIT and a list with the 4 programmable commands will be displayed.



- 3) Using the arrow   keys, highlight the command (CLOSE, OPEN, INT1, INT2) whose duration you want to set and touch the MODIFY  button. The selected command's present duration in milliseconds will be highlighted. Please

refer to the PME-500-TR user's manual for a better understanding of these commands in the context of circuit breaker testing.

- 4) Increase or decrease the duration time with the   arrow keys in 10-ms steps and confirm the desired value touching the ENTER  button.
- 5) Repeat the above steps 3 thru 4 until you are done with all the changes. Then, use the arrows to highlight the word EXIT and press ENTER  to leave the DURATION adjustment menu.

### 5. Resetting the recharge controller

The PME-500-TR features an internal statistic control that prevents the battery from overcharging. The calculations made by this protection can accumulate errors that may eventually shorten the allowed recharge time excessively. The following procedure resets the statistic counters to restore the charging time to the maximum:

- 1) Turn the unit off and plug the power cord into an AC outlet. The *charging* symbol will flash in the upper right corner of the LCD screen. When this symbol disappears, unplug and plug the AC cord, and wait for the *charging* icon to disappear again.
- 2) Unplug the power cord, turn the PME-500-TR on and wait until it switches itself off by lack of power. Do not use the backlight.
- 3) Plug the AC cord in and turn the unit on. Go to the  menu and touch underneath the lower corners of the  button to display the internal counters screen, as shown below:

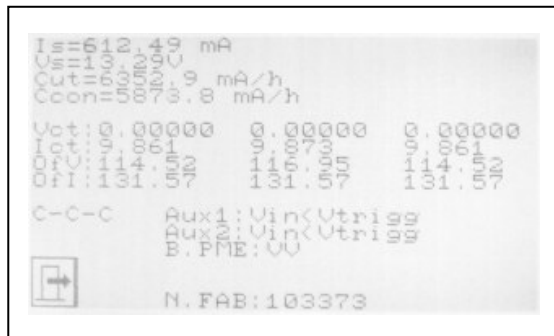
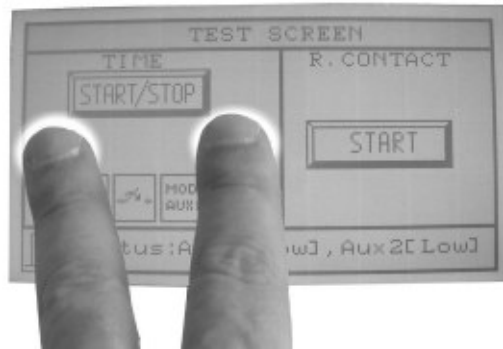

- 4) Turn the unit off. The counters screen will stay displayed with numbers showing the charging progression. The recharging symbol will also be flashing at the upper right corner.
- 5) Wait until the display vanishes out, so indicating the end of a complete recharge.

You only need to repeat the above steps whenever you experience too short a battery life after a full 4-hour recharge cycle with the unit switched off.

## After-sales Service and Warranty

### WARRANTY

This is an expression of trust that our products obtain, based on the reliability and functionality standards that our customers expect.

The warranty covers the free replacement or repair of defective components for one year in the terms specified in the supplied warranty statement and registration card.

Damages resulting from improper handling of the product, use outside the scope and limits of the product's specifications, negligence, installation not in accordance with the standards or warnings listed in the Instructions Manual and servicing or manipulation by unauthorized persons are not covered by the warranty.

### CUSTOMER SUPPORT

EUROSMC guarantees the supply of materials and components for its products up to 3 years after discontinuation. This support is extendable to 5 years for technical service.

## OTHER EUROSMC PRODUCTS

Portable Relay Test Equipment and Software

Primary injection units up to 20,000 A

Digital handheld chronometer.

Digital handheld phase angle meter

Digital Portable microhmmeter up to 100 A Test current.

Test systems for automatic miniature circuit breakers.

Voltage and current regulation equipment.

Step & Touch Voltage measurement equipment