

SVERKER 900

Relay and Substation Test System

User's Manual



Megger

WWW.MEGGER.COM

SVERKER 900

Relay and Substation Test System

User's Manual

NOTICE OF COPYRIGHT & PROPRIETARY RIGHTS

© 2013, Megger Sweden AB. All rights reserved.

The contents of this manual are the property of Megger Sweden AB. No part of this work may be reproduced or transmitted in any form or by any means, except as permitted in written license agreement with Megger Sweden AB. Megger Sweden AB has made every reasonable attempt to ensure the completeness and accuracy of this document. However, the information contained in this manual is subject to change without notice, and does not represent a commitment on the part of Megger Sweden AB. Any attached hardware schematics and technical descriptions, or software listings that disclose source code, are for informational purposes only. Reproduction in whole or in part to create working hardware or software for other than Megger Sweden AB products is strictly prohibited, except as permitted by written license agreement with Megger Sweden AB.

TRADEMARK NOTICES

Megger® and Programma® are trademarks registered in the U.S. and other countries. All other brand and product names mentioned in this document are trademarks or registered trademarks of their respective companies.

Megger Sweden AB is certified according to ISO 9001 and 14001.

Postal address:

Megger Sweden AB
Box 724
SE-182 17 DANDERYD
SWEDEN

Visiting address:

Megger Sweden AB
Rinkebyvägen 19
SE-182 36 DANDERYD
SWEDEN

T +46 8 510 195 00 seinfo@megger.com
F +46 8 510 195 95 www.megger.com



Contents

1 Safety

	6
1.1 General.....	6
Symbols on the instrument	6
1.2 Safety instructions.....	6

2 Introduction

	8
2.1 General.....	8
2.1 Unpack system.....	8
2.2 Service and support	9
Training	9
Contact information	9

3 Instrument description

	10
3.1 Panel	10
3.2 The lid	10
3.3 Binary Inputs.....	11
3.4 Binary Output	11
3.5 Current generators: I1, I2, I3	12
3.6 Voltage generators: U1, U2, U3 and U4	13
Voltage generator U4 as DC supply.....	13
3.7 Extra timer	14
Start and Stop conditions.....	14
3.8 A-meter/V-meter	15
Voltage.....	15
Current.....	15
Ammeter and Voltmeter windows.....	15
Other entities.....	16
3.9 USB port	16
USB 2.0 Interface	16
Firmware upgrade via SVERKER 900 USB port....	16
USB software upgrade	16
3.10 Ethernet port	17
3.11 Low current generation (Optional)	17

4 Operating SVERKER 900

	18
4.1 Local interface	18
Display buttons.....	18
Start SVERKER 900	18

4.2 Home menu.....	18
Home menu buttons.....	18
System configuration	19
4.3 Main instrument	20
Main instrument buttons	20
Generator settings	20
No generating mode.....	20
Generating mode	20
Numerical keypad	21
Equals.....	21
Setting frequency to DC.....	21
Balance.....	21
Finding the pick-up and drop-off value using the hold function	22
Binary Inputs.....	22
BI window buttons	22
Make BI settings	23
Debounce filter	23
Special settings available for BI1	23
4.4 Prefault->Fault instrument	25
Prefault->Fault view	25
Navigation	25
Prefault-> Fault instrument buttons.....	25
Prefault view.....	25
Fault view	25
Automatic Prefault->Fault button.....	25
The phase angle graph	26
4.5 Ramping instrument	26
Ramping view	26
Navigation	26
Ramping instrument buttons.....	26
Start a ramp test.....	27
Speed and Stop ramping set views.....	27
The phase angle graph	27
4.6 Sequencer instrument.....	27
Navigation	27
Sequencer instrument buttons	27
4.7 CT magnetization instrument.....	30
CT magnetization instrument buttons	30
Set-up	30
Manual test	31
Manual/auto test	32
Auto test	32

Demagnetization	32
4.8 Test file management.....	33
Buttons in Test file management	33
Save a test	33
Quick save	34
View and reuse test files	34
Storage file	34
Reference file.....	34
Transfer files to PC	34
Copy test files from USB stick to SVERKER 900...	35
5 Troubleshooting and Error messages	36
6 Specifications	38
Index	42

1 Safety

1.1 General



Important

Read and comply with the following instructions.

Always comply with local safety regulations.

Symbols on the instrument



Caution, refer to accompanying documents.



Protective conductor terminal.



WEEE, Waste Electrical and Electronic Equipment. Please utilize your local WEEE collection facilities in the disposition of this product and otherwise observe all applicable requirements.

1.2 Safety instructions



Warning

- 1] High voltage/current on output terminals.
- 2] The instrument is equipped with a power cord with integral safety ground pin. The equipment must be connected to a grounded mains outlet.
The instrument case must also be grounded by the separate protective ground wire with connection to the protective earth terminal on the rear panel. This is to eliminate difference in earth potential between the instrument and the device to be tested. Check the continuity of the protective ground wire before each use.
- 3] Do not attempt to service the instrument yourself. Opening or removing covers may expose you to dangerous voltage. If you attempt to service the instrument yourself the warranty is no longer valid.
- 4] Do not use any accessories that are not intended for use together with the instrument.
- 5] Do not use the instrument for any purpose other than indicated by the manufacturer.
- 6] If the equipment is used in a manner not specified by the manufacturer, the protection provided by the equipment may be impaired.
- 7] Disconnect the instrument from the mains before cleaning. Use a damp cloth for cleaning. Do not use liquid cleaners or aerosol cleaners.



Important

- 1] Always turn the equipment off before connecting.
- 2] Always use manufacturer approved and supplied cable sets.
- 3] Always connect protective earth (ground).
- 4] Slots and openings in the instrument are provided for ventilation. They ensure reli-

able operations, keeping it from overheating. These openings must not be blocked nor covered during operation.

- 5]** The instrument may not be positioned so that the mains switch is blocked.
- 6]** The mains connector may not be used as disconnecting device.
- 7]** The plug to the mains inlet is to be used as disconnecter.
- 8]** Never leave the instrument unattended while it is turned on and in the high-current mode.
- 9]** Use only approved mains detachable cable set with the instrument. Main supply cables shall be rated for the maximum current for the equipment and the cable shall meet the requirements of IEC60799 (Cord sets and interconnection cord sets). Mains supply cables certified or approved by a recognized testing authority are regarded as meeting this requirement.
- 10]** Unplug the instrument from the mains supply when it is left unattended or not in use.
- 11]** Do not expose the instrument to rain or moisture.
- 12]** Refer all servicing to Megger authorized personnel.
- 13]** If you need to return the instrument, please use either the original crate or one of equivalent strength

2 Introduction

2.1 General

The SVERKER 900 is an instrument designed for testing of electrical equipment in substations, e.g. protective relay systems.

The rugged hardware design is built for field use over a wide temperature range.

SVERKER 900 is a three-phase test equipment. It can generate voltage and current from its four voltage generators and three current generators respectively, receive binary inputs and a binary output that is a make/brake contact.

SVERKER 900 can measure external voltages and currents as well, and properties like level, phase, power factor and frequency of each. The voltage and current generator outputs can be activated in many combinations. It also includes an external timer with various start and stop conditions.

All setting for the instrument are made using the touch screen. The main instrument includes the "ON+TIME" and "OFF + TIME" functionality.

Another instrument is the prefault fault sequence with binary input used for trip signals.

The Ramping instrument is used to ramp voltage or current.

The Sequencer instrument tests states of a circuit breaker for the automatic recloser.

The CT magnetization instrument is for testing current transformers.

2.1 Unpack system

Unpack the unit and check for evidence of any shipping damage. If there is any visual damage, immediately notify the freight carrier to make a damage claim, and notify Megger of the damage.

2.2 Service and support

For technical assistance please contact your local representative or direct your request to Megger in Sweden.

When sending the instrument, please use either the original crate or one of equivalent strength.

Add the return authorization number to the address label of the shipping container for proper identification and quicker handling.

Note *Ship the equipment without nonessential items such as test leads, etc. These items are not needed by the factory to perform service.*

Training

For information about training courses contact your local distributor or the Megger Sweden office.

Contact information

Internet: www.megger.com
E-mail: support-sweden@megger.com
Tel: +46 8 510 195 00
Fax: +46 8 510 195 95

3 Instrument description

3.1 Panel

1. Binary inputs
2. Binary output
3. F2 fuse
4. Current generators I1, I2, I3
5. Voltage generators U1, U2, U3
6. Voltage generator U4 or DC supply
7. Control knob
8. Touch screen
9. Power ON/OFF switch
10. Mains inlet socket
11. Protective earth terminal
12. Ethernet port
13. USB port
14. Extra timer
15. Ammeter & voltmeter

3.2 The lid

Inside the lid are:

- Jumpers
- CTM-box for use with the CT magnetization instrument
- Pen to use for the touch screen

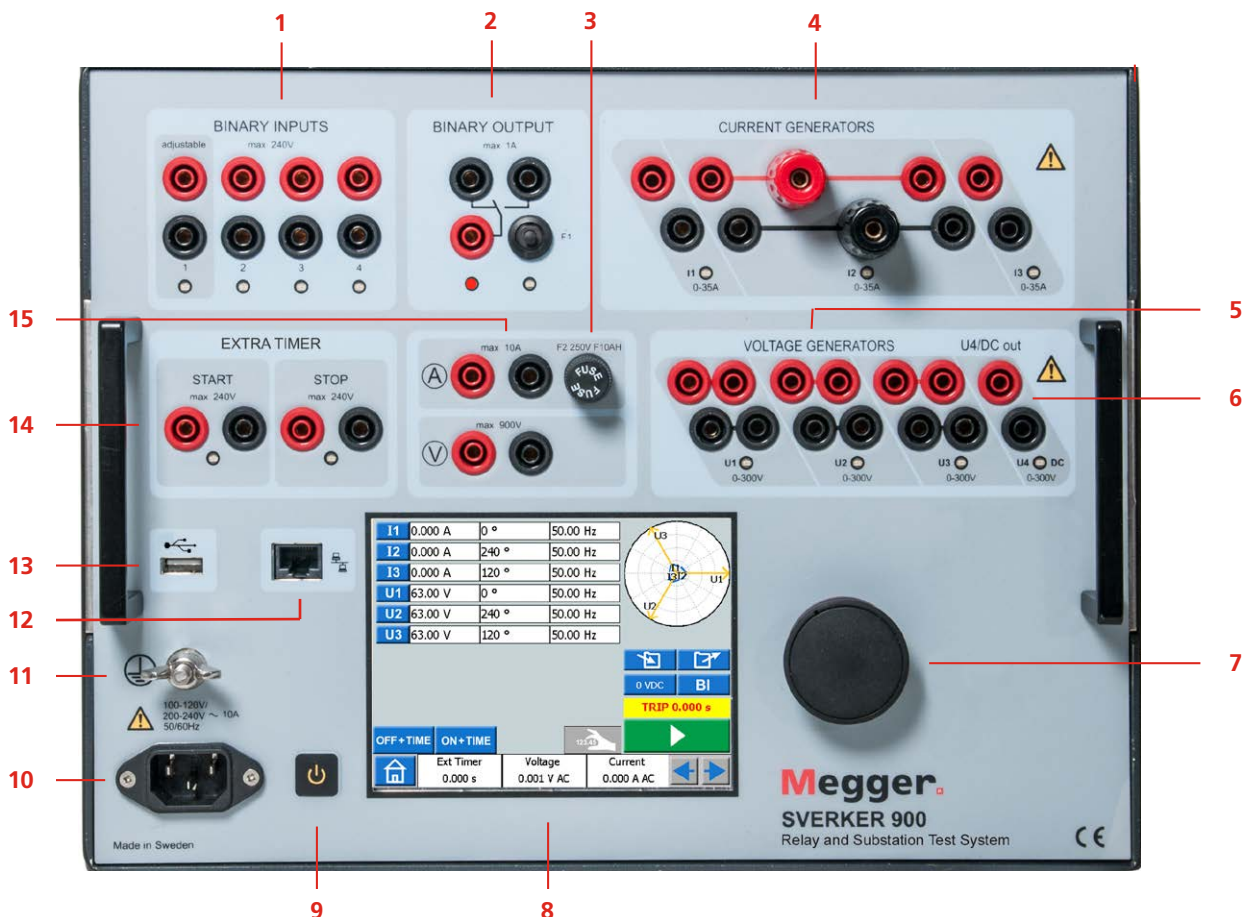

3.3 Binary Inputs

The SVERKER 900 have 4 binary inputs, independent programmable gate circuits that permit simple selection of the desired mode for voltage or contact monitoring operation. Binary input 1 has a selectable threshold voltage.

The binary inputs are used to monitor relay trip contacts for performing pickup and dropout tests as well as for performing timing functions.

The binary inputs are specifically designed to measure high speed operation of electromechanical, solid-state and microprocessor-based protection relays. All binary inputs are default set to monitor mode, contact /voltage change of state.

To change a binary input state from contact sensing to voltage applied / removed, touch the "BI" button.

At each binary input there is an input state indicator lamp that shows the state of the input. It indicates either a closed circuit (for contact mode) or the presence of a voltage (for voltage mode). These indicators permit (for example) to check the circuits involved before starting a sequence.

Dry contacts Open	Timer stops and a continuity indicator goes out at the opening of normally closed contacts.
Dry contacts Close	Timer stops and a continuity indicator glows at the closing of the normally open contacts.
Application or removal of AC or DC voltage	<p>Timer stops. The continuity indicator will glow (application) or darkens (removal) upon the application or removal of either an AC or DC voltage. A higher threshold voltage helps to eliminate false triggers due to a noisy source. Lower thresholds allow starting and stopping of timer from TTL voltage signals.</p> <p>Binary input 1 has a settable threshold value for pickup & dropout and minimum settable threshold voltage is 5 V</p>

3.4 Binary Output

The binary output is a make/break contact that is actuated when the SVERKER 900 is set to ON-generating or OFF-generating mode.

Note *It is only in the "Sequence instrument" the output can be selected to ON- or OFF-generating mode position.*

The binary output is used to simulate normally open/normally closed contacts for testing breaker failure schemes, or similar power system operations. In addition it may also be used to switch AC/DC voltages and currents.

For maximum switching capacity see the specification section.

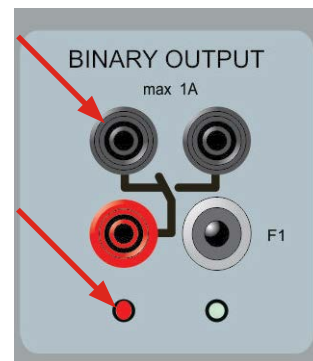

BO position when SVERKER 900 is OFF (not generating). Left terminal is on.

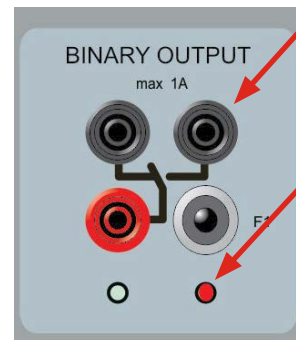

BO position when SVERKER 900 is ON (generating). Right terminal is on..

3.5 Current generators: I1, I2, I3

The current generators can be used separately, in parallel or in series. Constant power output in many cases eliminates the need to connect the current channels in parallel or series to test high burden relays.

- All outputs are isolated or floating and provide variable frequency.
- The current generators delivers maximum compliance voltage to the load constantly during the test, and range changing is done automatically, on-the-fly, under load.

The per channel output current and power ratings are specified in AC rms values. Specified duty cycles are based upon ambient temperature of 20°C.

Note *The current amplifiers outputs are protected from open circuits and thermally protected against prolonged overloads. In case of an open circuit or a thermal overload, the amplifier will automatically turn off, and an error message will be displayed.*

Current generators separately: I1, I2, I3

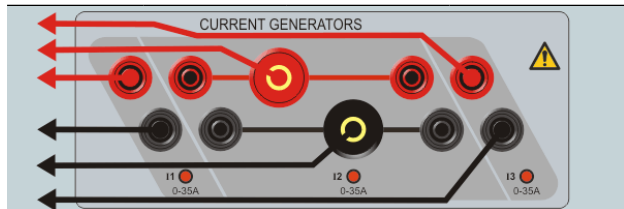

Current	Power (max)	Voltage (max)	Duty cycle
5 A	250 VA	50 V	Continuous
10 A	250 VA	25 V	Continuous
20 A	200 VA	10 V	Continuous
35 A	100 VA	2.8 V	10sON/20sOFF*

*Thermo protected

Current generators in parallel: I1 // I2 // I3

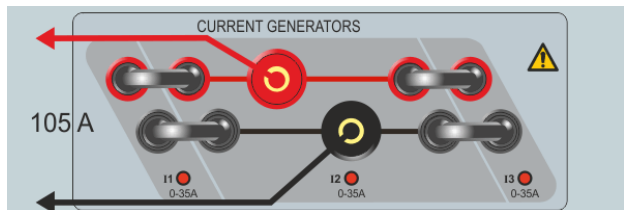

Current	Power (max)	Voltage (max)	Duty cycle
15 A	750 VA	50 V	Continuous
45 A	750 VA	16.5 V	Continuous
60 A	600 VA	10 V	Continuous
105 A	300 VA	2.8 V	10sON/20sOFF*

*Thermo protected

Current generators in series: I1 – I2 – I3

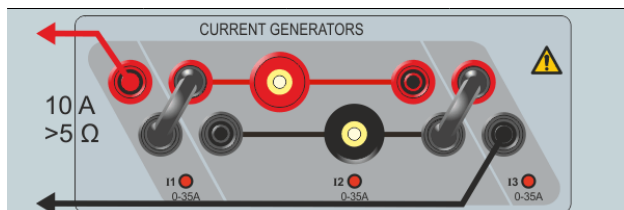

Current (max)	Power (max)	Voltage (max)	Duty cycle
10 A	625 VA	140 V	Continuous

External load: min. 5 Ω
Frequency: max 200 Hz

3.6 Voltage generators: U1, U2, U3 and U4

The voltage generators can be used separately, in parallel or in series.

- All outputs are independent from sudden changes in mains voltage and frequency, and are regulated so changes in load impedance do not affect the output.
- All outputs are isolated or floating.
- All outputs provide variable frequency.

Voltage generator U4 as DC supply

The primary application for U4 is to provide DC voltage for protective relays. U4 provides a variable DC output from 0 to 300 V DC.



Warning

Do not plug or insert any test lead into the voltage outputs without first connecting the test leads to the load.

When voltage generators are connected in series for output over 600 V the special test leads (brown and purple) must be used.

Voltage generators separately: U1, U2, U3, U4

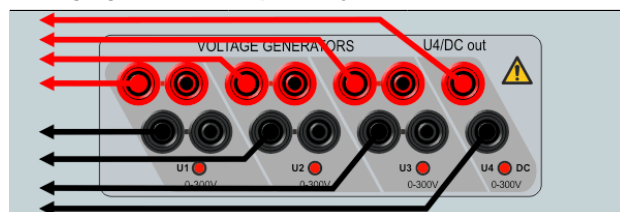

Voltage range	Power (max)	Current (max)
300 V	125 VA	0.42 A
100 V	100 VA	1.0 A
67 V	100 VA	1.5 A
External load: min. 25 Ω		

Voltage generators separately: U1, U2, U3 (U4 DC)

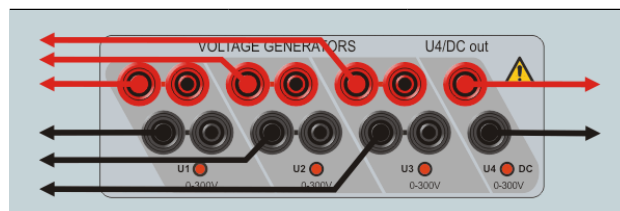

Voltage range	Power (max)	Current (max)
300 V*	125 VA	0.42 A
* U4 DC		

Voltage generators in parallel: U1 // U2 // U3 // U4

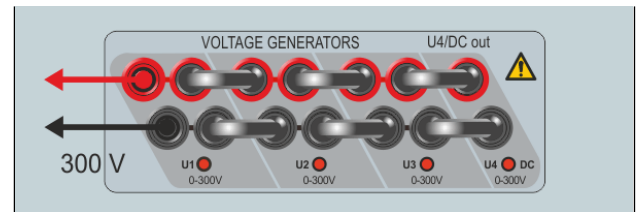

Voltage range	Power (max)	Current (max)
300 V	375 VA	1.2 A
100 V	300 VA	3.0 A
67 V	300 VA	4.5 A
External load: min. 7 Ω		
Frequency: max. 200 Hz		

Voltage generators in parallel: U1 // U2 // U3 (U4 DC)

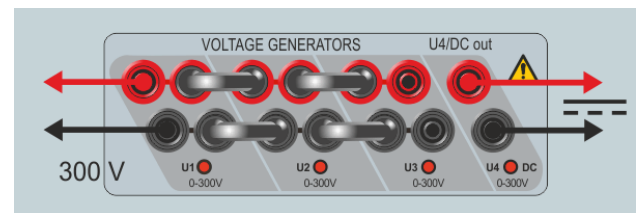

Voltage range	Power (max)	Current (max)
300 V	312 VA	1.0 A
100 V	250 VA	2.5 A
67 V	250 VA	3.7 A
External load: min. 9 Ω		
Frequency: max. 200 Hz		

Voltage generators in series: U1–U2–U3–U4

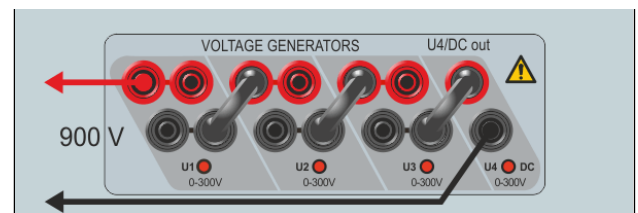

Voltage range	Power (max)	Current (max)
900 V	450 VA	0.5 A
400 V	360 VA	0.9 A
268 V	350 VA	1.3 A
External load: min. 100 Ω		
Frequency: max. 200 Hz		

Voltage generators in series: U1–U2–U3 (U4 DC)

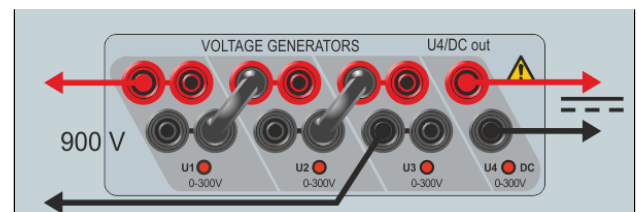

Voltage range	Power (max)	Current (max)
900 V	350 VA	0.4 A
300 V	280 VA	0.9 A
200 V	275 VA	1.4 A
External load: min. 75 Ω		
Frequency: max 200 Hz		

3.7 Extra timer

The SVKER 900 has two independent gate inputs that permit simple selection of the desired mode for timing operation.

To monitor operation of the contacts in the device under test, a light is provided for each gate. The gate circuit is isolated for voltage-sensing and can monitor solid-state logic signals. Each light will illuminate once contacts close or voltage is applied to the gate.

- 1] Press "Ext Timer" at bottom of display, from any of the instruments.
A new window opens.

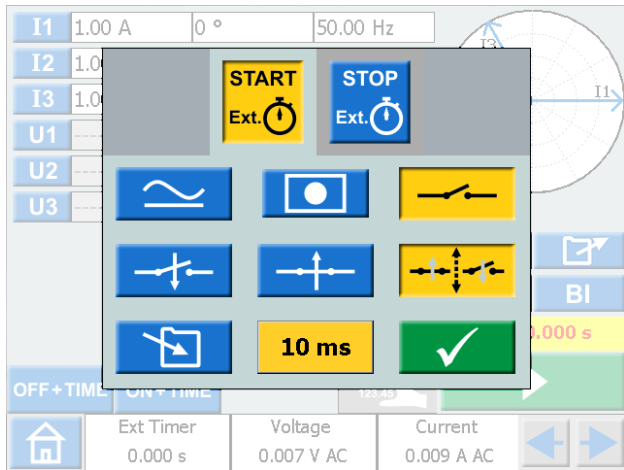

- 2] Make settings for the START and STOP conditions.
The conditions can be set different for START and STOP.

Start and Stop conditions

Condition	START Ext.	STOP Ext.	Description
			The settings for starting and stopping are done independently..
			At application of either an AC or DC voltage.
			At removal of either an AC or DC voltage.
			At application or removal of AC or DC voltage.
			At the opening of normally closed contacts
			At the closing of normally open contacts

	When a generator is turned on or off, or that a trip signal stops the generating or that an open current circuit is detected.
--	---

Other functions

10 ms	Filter time can be set from 0 to 999 ms.
	The timer value is stored Note: The timer value can not be saved separately only together with a test made in any instrument.

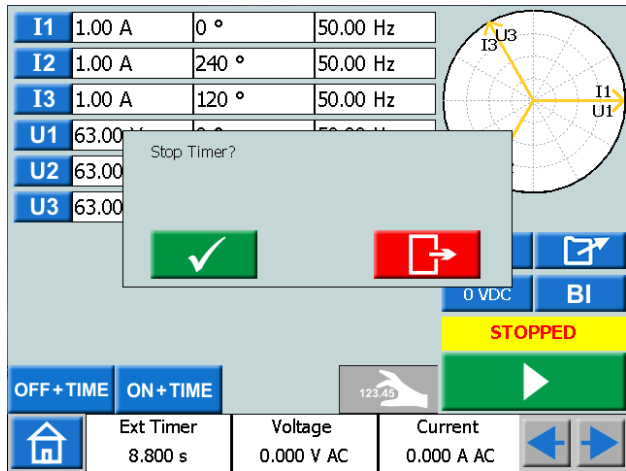

If the "Ext.timer" has failed to stop, it can be manually stopped and reset.

- 1] Press "Ext Timer" and then .

3.8 A-meter / V-meter

SVERKER is equipped with an ammeter and voltmeter.

These instruments can also be used to display resistance, frequency, impedance, phase angle, power and power factor. Moreover, these instruments can be used to perform measurements in external circuits. In both cases, the values appear on the display.

The ammeter input (marked "A") measures 0–10 A (ACrms or DC) in an external circuit.

The voltmeter input (marked "V") shows the voltage connected to the voltmeter on the panel. The voltmeter can be used to measure up to 900VAC or DC. It can be set in ranges or automatically mode.

- 1] Press "Voltage" or "Current" at bottom of display, from any of the instruments. You will see the respective new windows below.

Voltage

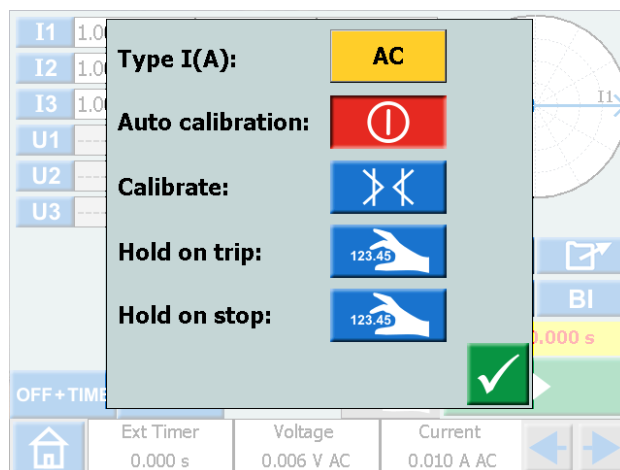

Current

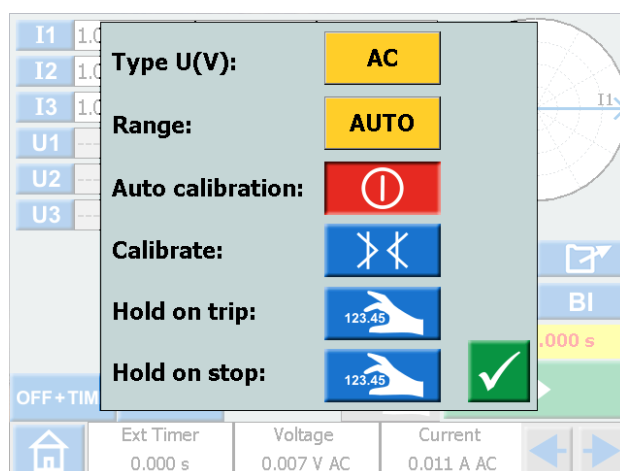



Ammeter and Voltmeter windows

Type U (V)	Select AC or DC
Range	Auto, 0-9 V, 9-90 V, 90-900 V
Type I (A)	Select AC or DC
Auto calibration	The auto calibration can be set to on or off individually (Ammeter/ Voltmeter). If auto calibration is set to "ON" it will recalibrate the offset each 10 minutes period and also do an offset calibration within 5 minutes if the temperature is changed.
Calibrate	The AC and DC offset will be calibrated.
Hold on trip	The value measured on the volt and/or ammeter is frozen when a trip signal has been detected. The "ON+TIME" has to be activated. 1] Press  to activate the HOLD function in the volt and/or current menu. The Voltage and/or Current field turns blue and at trip it turns yellow. The voltage and current values can be stored to a test file. A] In the Main menu, the voltage and current values for pick up-drop off, can also be locked. B] In the Ramp instrument this will be valid for a whole ramp sequence. C] In the Prefault/fault instrument this will be valid for fault state and prefault+fault state

Hold on stop	<p>Values from the volt and/or ammeter are held after stop of generating.</p> <p>If the timer is not stopped, the values present when the current was interrupted are frozen.</p> <p>1] Press  to activate the HOLD function in the volt and/or current menu.</p> <p>The Voltage and/or Current field turns blue and at stop it turns yellow.</p> <p>The volt and current values can be stored to a test file.</p> <p>A] In the Main menu, the voltage and current values for pick up-drop off, can also be locked.</p> <p>B] In the Ramp instrument this will be valid for the start ramp value and for the whole ramp sequence.</p> <p>C] In the Prefault/fault instrument this will be valid for predefault state, fault state and predefault+fault state</p>
---------------------	---

Note *If O.L. (Over Load) appears, the cycle being measured may have been so fast that there was not time for automatic range changing, or that the range was overridden. If over 900 V or 10 A, it gets +OL.*

Other entities

- 1] By pressing the   buttons you can view the Frequency (Hz), Power (VA and W) , Impedance (R and Z) and phase angle values.

3.9 USB port

USB 2.0 Interface

The USB port is used to:

- Update the firmware in the SVERKER 900
- Update the software
- Connect a mouse or keyboard
- Download test files from the SVERKER 900 Local for transfer data, e.g. to a PC for storage or printing.
- Copy test files from USB to SVERKER 900

Firmware upgrade via SVERKER 900 USB port

- 1] Contact Megger Sweden AB technical support to get a USB memory stick with upgraded files.

USB software upgrade

- 1] Before startup, insert USB memory stick, with new software, to the USB port. SVERKER 900 scans the available files in the USB memory. If a bootable image can be found and the image signature is newer than the currently installed image, you are asked to upgrade SVERKER 900. After loading new software you must reboot.
- 2] Press and hold (5 s) the  button to reboot.

3.10 Ethernet port

Note *The Ethernet port is used for service of the instrument only.*

3.11 Low current generation (Optional)



An optional accessory (CR-91010) is the Low Current Adapter. The adapter consists of two boxes LCA1 and LCA2. It is used to test e.g. sensitive earth fault protection, capacitor unbalance protection and three phase reverse power protection.

The LCA1 and LCA2 are to be connected to the current generator outputs, see figure below, for generation of low currents, 0–30 mA. The built in ammeter, in SVERKER 900, is connected to measure the current injected into the test object.

The ratio between the input and output currents is somewhat depending on the load, e.g. a 0.5Ω load and 1 A current generation gives an output of 9 mA.

Max current input is 5 A.



4 Operating SVRERKER 900

4.1 Local interface

The SVRERKER 900 local interface is the manual control and user interface for the unit. All manual entries will be made through the SVRERKER 900 local interface.

Display buttons

The buttons are of two types, momentary and switch.

- Momentary buttons are always blue.
- Switch buttons change from blue to yellow in active mode.
- Disabled buttons are grey.

Start SVRERKER 900

- 1] Plug the unit line cord into an appropriate power source and press the button .

During the power up sequence the test system automatically run a self-test to insure everything is operating properly. When this is done the Main instrument screen is presented. This is the default screen and depending on how the channels are configured the SVRERKER 900 will display and provide the appropriate number.

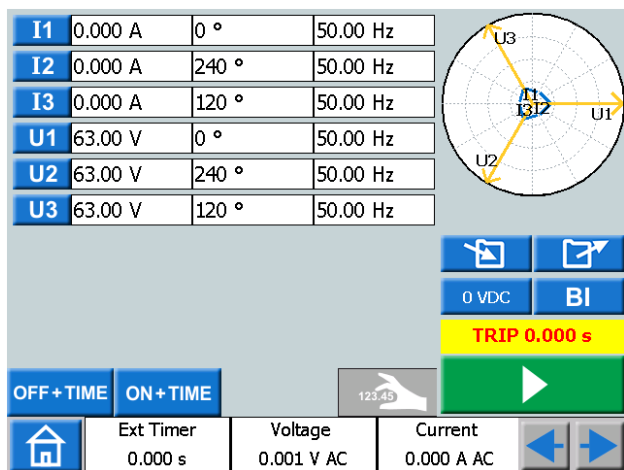

From the Main instrument you can perform the general tests with SVRERKER, see section "4.3 Main instrument" on page 20

The other instruments are available from the Home menu.

- 1] Press  for the Home menu





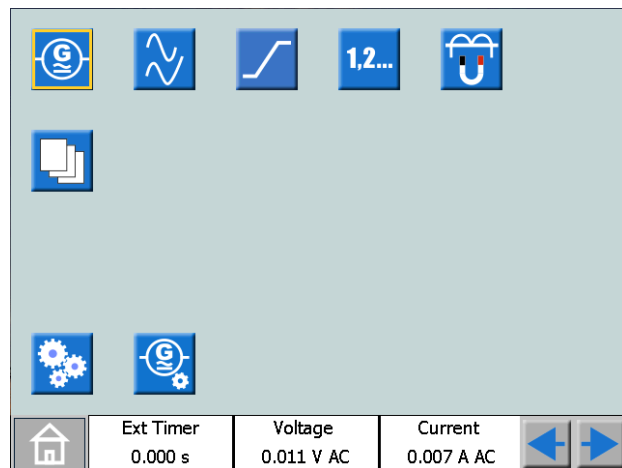

4.2 Home menu

In Home menu  you can:

- Select type of test instrument
- Select system configuration
- Activate already saved test files or download on external memory (USB)
- Select Voltage / Current and External Timer configuration. This can also be done in all the test menus.



Home menu buttons

Symbol	Description
	Main instrument The Main instrument screen is the default screen for SVRERKER 900, and is presented when started.
	Default -> Fault instrument
	Ramping instrument
	Sequencer instrument
	CT-Magnetization instrument
	Test file management
	System configuration

Home menu buttons

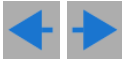
Symbol	Description
	Configuration of Voltage / Current generators
	Browse left/right

System configuration

1] Press  for the Home menu

2] Press 

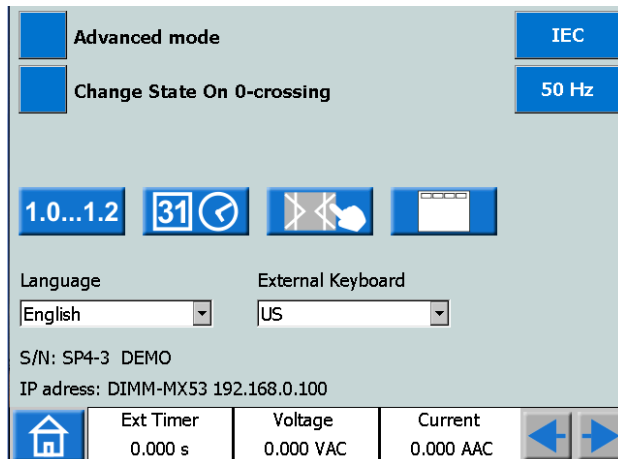

■ Advanced mode

Advanced mode, OFF or ON, enables the harmonics function.

■ Change State On 0-crossing

Setting of how to change state in the Sequencer instrument.

When "Change State On 0-crossing" is OFF it means that the curve form (amplitude, phase, frequency) is changed immediately if amplitude or phase or frequency is changed between the different states.

When "Change State On 0-crossing" is ON it means that the state is not finished until the curve form reaches the zero crossing. Then the state is completed.

■ IEC / IEEE

Select Standard

Applicable for the CT-Magnetization instrument

■ 50 Hz / 60 Hz / 16 2/3 Hz

Select frequency

■ Versions

1.0...1.2

About SVERKER 900: year manufactured etc.

■ Date and time setting

31 ↻

■ TouchCal



Follow instructions for calibration.

If no keyboard is used press middle of screen when new calibration is done.

■ Labels for test files



Setting of four fields for report handling.

Note: The language setting for the volt and ammeter is shifted when instrument is restarted.

■ Language

Czech, English, French, German, Spanish, Swedish

■ Ext.KeyBoard

Select language for an external keyboard.

4.3 Main instrument

The Main instrument screen is the default screen for SVKER 900, and is presented when started.

SVKER 900 will be opened with the settings from last time it was run.

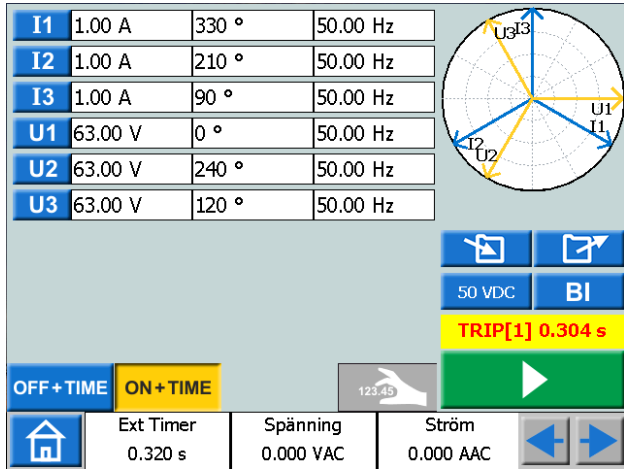

In the example above all current and voltage generators are set to work separately. See sections "Current generators separately" page 12 and "Voltage generators separately" page 13. for configuration.

Main instrument buttons

Symbol	Description
U1 I1 U2 I2 U3 I3 U4	Voltage and current generators <ul style="list-style-type: none"> Parameter table rows turns into green for active generators. Press parameter to make settings.
OFF + TIME	OFF+TIME: Current source is turned off. When a valid trip indication occurs, the yellow Trip time field shows the trip time and the binary input that detected the trip signal
ON + TIME	ON+TIME: Current source is activated until the object being tested has operated. When a valid trip indication occurs, the yellow Trip time field shows the trip time and the binary input that detected the trip signal.
123.45	HOLD: Captures voltage or current value at trip signal.
	SAVE Test
	OPEN Test
0 VDC	U4-DC: Setting the voltage for the U4 generator When used as DC supply in voltage configuration
BI	BI: Configuration of the binary inputs
=	Equals values for current, voltage and frequency
	Balances the phase angle values
	Run
	Stop
	Returns to Home menu

Generator settings

SVKER 900 can be configured in different generator modes. Voltage and current generators can be set to serial or parallel mode. This is done from the Home menu.

- 1] Press the button from the Home menu to configure the voltage and current generators. See sections page 12 and page 13.

In example below SVKER 900 is configured with 3 voltage generators in parallel.

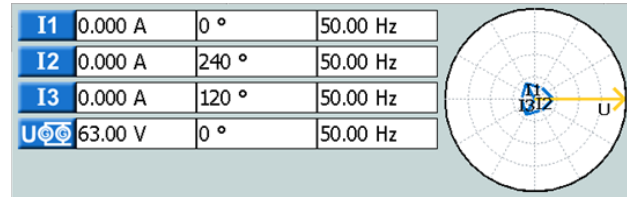

In example below SVKER 900 is configured with 3 current generators in parallel and 3 voltage generators in parallel

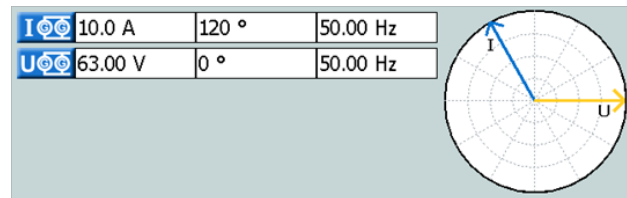

This picture below shows the voltage and current generators set in serial mode

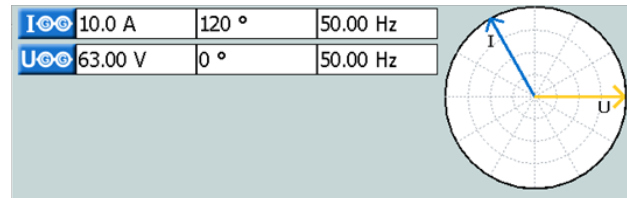

No generating mode

This is the default state for the Main instrument. All generator outputs are inactive, not generating output.

- 1] In no generating mode, you can choose to activate one or more generators and configure the voltage, current, phase and frequency parameters, for each.
- 2] Select a parameter to configure, the on-screen numerical keypad will show up.

Generating mode

Selected generators will be activated.



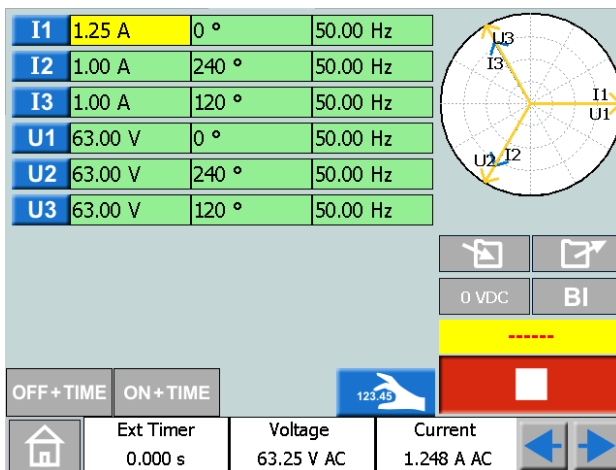

- 1] Press You can manually increase or decrease a selected parameter using the control knob and observe the output.



Note Any combination of parameters can be selected to be manually operated when generating is on. Press on the desired parameters to change and turn the control knob.

Press  to stop the output

OFF+TIME

- 1] Press 
- 2] Press 
- 3] Press  to stop the output. The button changes to  and the timer starts counting.

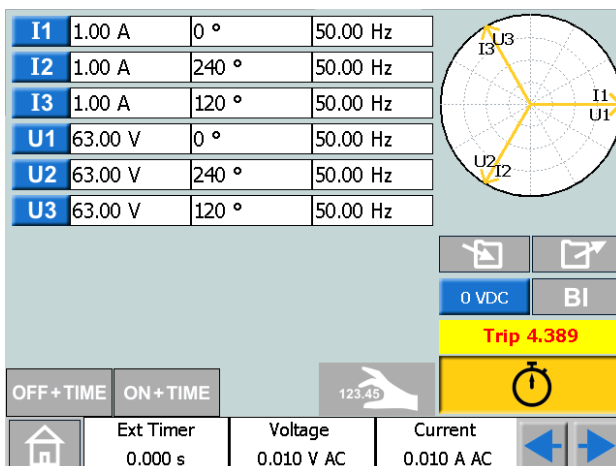

- 4] When a trip has been identified on any of the binary inputs the sequence is ended, clock stops and result is displayed.



Picture shows trip on binary input 2 after 3.044s.



ON+TIME

- 1] Press 
- 2] Press 

- 3] When a trip has been identified on any of the binary inputs the sequence is ended, clock stops and result is displayed

Numerical keypad

The keypad view always shows up when you select a configurable parameter on screen but only when the generators are inactive.

- 1] Use the on-screen numerical keypad for configuration of test parameters.
- 2] Use the  button to confirm the entered value or the  button to abort and exit.



Equals

When you select to configure the voltage level, current level or the frequency parameter, you will find the button 

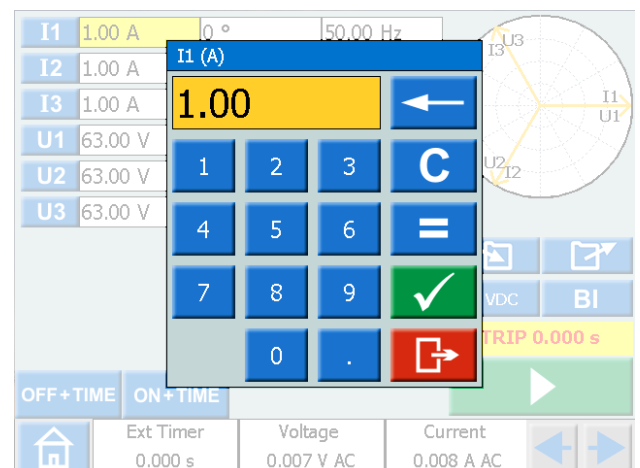
- 1] Enter desired value and press . All three VGs or CGs will be configured with the same value.



Setting frequency to DC

- A] Press "0" and then twice the  to set DC output on the selected channel.
- B] Press "0" and then press twice on the button  to set DC output on all channels.

Balance

When you select to configure the phase angle parameter for a selected generator, you will find the button 

- 1] Enter desired value and press  button. The phase angle between the VGs or CGs will be balanced by 120 degrees.

Example:

You configure the UL2 angle to 240 degrees and press the BALANCE button.

UL1 = 0 deg (= 240 + 120)

UL2 = 240 deg

UL3 = 120 deg (= 240 - 120)

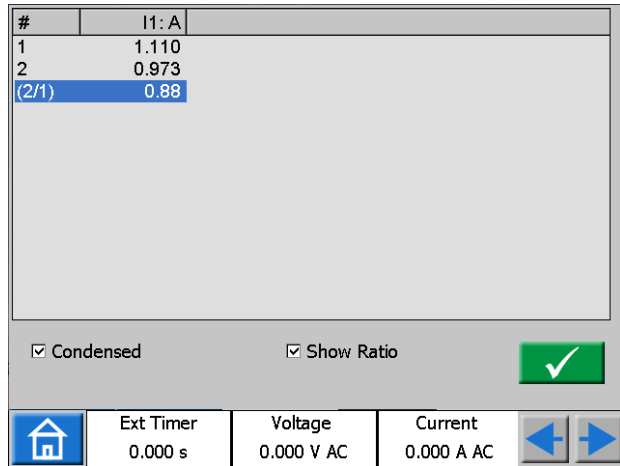
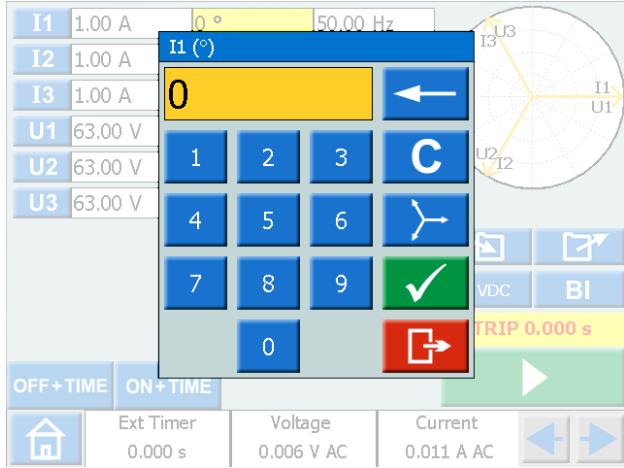

When the "condensed" view is selected, only the generators used are shown. The check box "Condensed" is in bottom of the result window.

Note You can return to the result window by pressing the yellow field above the button.

Finding the pick-up and drop-off value using the hold function

- 1] Press
- 2] Press
- 3] Select a generator by pressing current or voltage field. The field turns yellow.
- 4] Turn the main knob clockwise to increase current or voltage. When a trip signal is detected on a binary input, the amplitude value is saved and a pick-up value is obtained.
- 5] Press again.
- 6] Turn the main knob anticlockwise to decrease current or voltage. When a trip signal is detected on a binary input, the amplitude value is saved and a drop-off value is obtained.
- 7] Press to stop the output. The result is shown on display, the pick-up and drop-off value and the ratio between the values.

Note You can return to the result window by pressing the yellow or red field above the button. When a test is saved the field is red.



Binary Inputs

The binary inputs are polarity sensitive when used in voltage DC mode. The continuity indicator will light if in right polarity and the contact condition is met. When the BI is set to voltage sense and a DC or AC signal is applied on the BI contact. A constant light is seen.

For binary input BI1 the trigger level can be defined (both from low to high and high to low level change) when voltage mode are selected. For BI2-BI4 the levels are fixed.

BI window buttons

Symbol	Description
	Binary input BI1. The trigger level can be defined (both from low to high and high to low level change) when voltage mode are selected. BI2–BI4. The trigger levels are fixed.
	Red dot. Indicates that input is active. >=1 Indicates that the input is logic connected to another input with OR function. & Indicates that the input is logic connected to another input with AND function.
	Voltage mode. Detects if voltage is applied or not.
	Contact mode. Detects if circuit is closed or not.
	Make. Trig when a voltage is applied to the start input or when a contact is closed.
	Break. Trig when a voltage applied to the start input vanishes or when a contact is opened.
	Make / Break. Trig when the state of the input changes.
	BI OFF. Turns off the selected binary input

	BI ON. Turns on the selected binary input
	Confirm. Settings are confirmed and window closes

Make BI settings

The procedure for BI-setting are the same in all menus except sequence instrument.

- 1] In Main instrument press 

The window shown below appears. Here you can see how the binary inputs are configured.

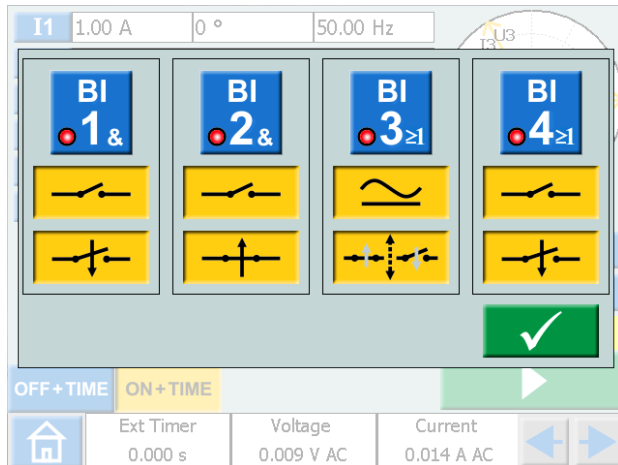

- 2] Press a BI button e.g. . The button turns yellow and settings can be done. The small red indicator tells that the BI is active.

The BI setting window is shown. Below is an example for settings of the binary inputs.

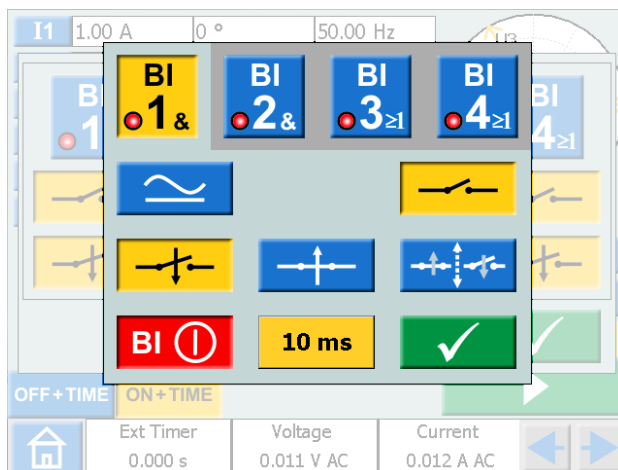

- 3] Press buttons for desired conditions for each BI, e.g. Contact or Voltage mode, Make or Break, or Make/Break.
- 4] Press  to turn off a BI. The button is greyed out and the red indicator is turned off.

OR / AND condition

The logical function for the binary inputs is normally "OR" but you can set two or more of the binary inputs to a logic "AND" condition.

- 1] Press twice on a blue (once on a yellow) BI to set to "AND" condition.
- 2] Press again to toggle.

Debounce filter

- 1] Press the "10 ms" button to set the debounce time.

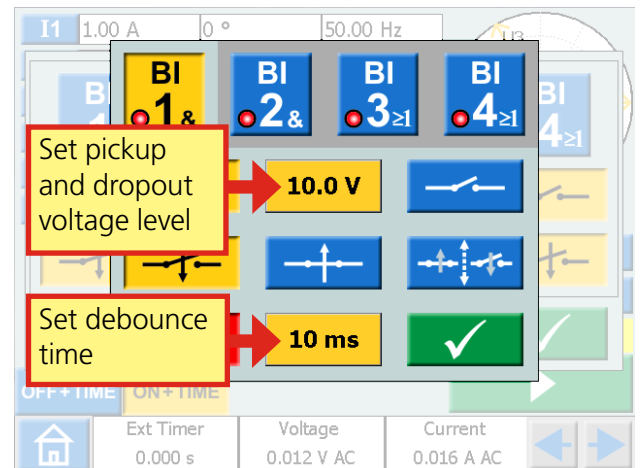

The debounce time for DC voltage can be set from 0 to 999 ms.

For AC voltage the debounce time has to be set to 5 ms.

Note *When set to zero, it actually means 2–3 ms. A debounce time of 0 ms is not a realistic value.*

The debounce time means that as soon as a signal (voltage or contact sense) is detected on the binary input, SVRERKER awaits the set debounce time. If the signal is active during the whole debounce time the signal is acknowledged as a valid signal, a "true" trip signal is confirmed.

Special settings available for BI1

Adjustable threshold voltage

When voltage sense is chosen for BI1, the adjustable pickup and dropout threshold values can be set between 5 to 240 V and 0 to 235 V.

- 1] Press the "10.0 V" button, see picture above, to set the threshold pickup and dropout value.

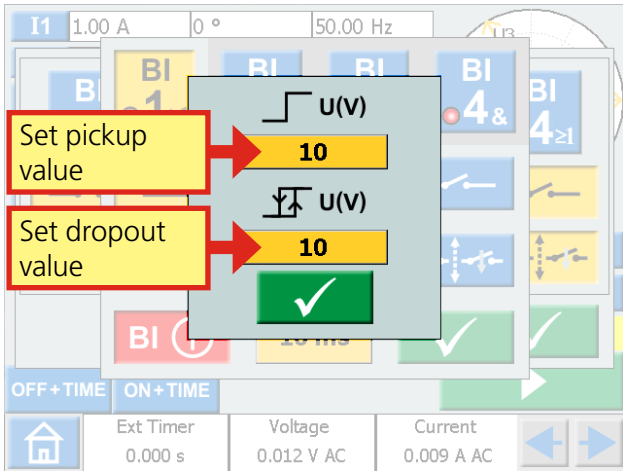

Hysteresis voltage

The hysteresis voltage is the difference between the pickup and dropout threshold voltages. If the pickup threshold voltage e.g. is set to 48 V and the dropout value is set to 5 V, the hysteresis voltage is 5 V.

- 1] Press the "10" buttons (see picture above) to set the hysteresis voltage.

Harmonics

To use the harmonics function SVRERKER 900 has to be set to "Advanced mode"

- 1] Press for the Home menu.
- 2] Press

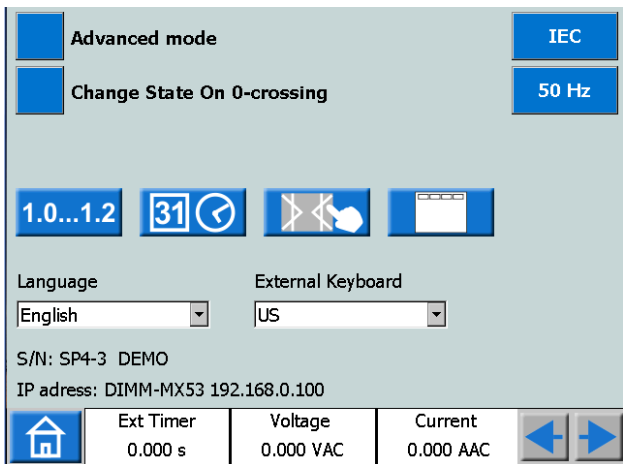

- 3] Press button **Advanced mode (OFF)**. It will change to **Advanced mode (ON)**. Each individual generator can now be set to generate a harmonic waveform.

Note *When the harmonics is enabled the parameter table has an orange outline.*

- 4] Press on e.g. U1. The harmonics instrument is shown.

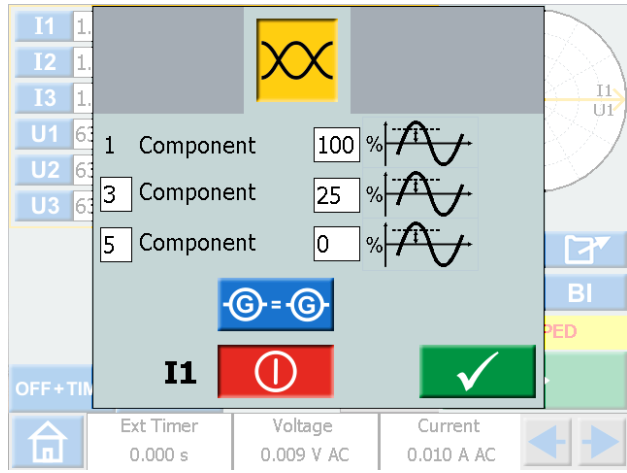

In this example you can see that a fault current at fundamental frequency with a superimposed third harmonic of 25% will be injected on generator U1.

- 5] Press the button to impose the same harmonics on the voltage or current channels.
- 6] Press to turn off a generator.

4.4 Prefault->Fault instrument

The Prefault->Fault instrument is selected from the Home menu using the button 

Using the Prefault->Fault instrument you configure two different states for the device, Prefault and Fault. You can configure and activate both stages individually and make SVRERKER 900 execute the test and automatically change from Prefault to Fault state.

The Prefault state configuration is a valid condition for the test object, meaning it does not trigger during operation.

The Fault state is an invalid condition and it will trigger the test object.

Prefault->Fault view

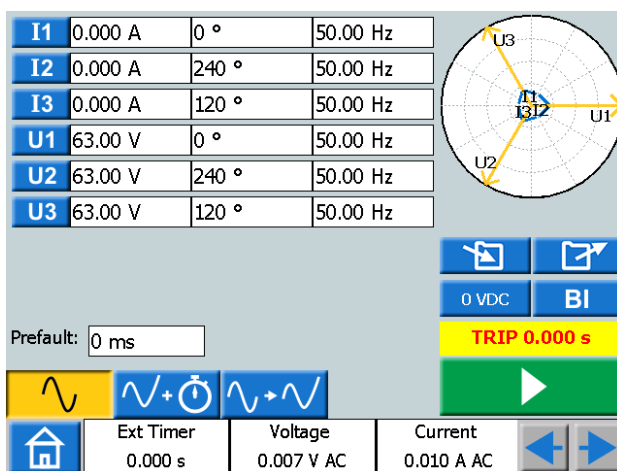

I1	0.000 A	0 °	50.00 Hz
I2	0.000 A	240 °	50.00 Hz
I3	0.000 A	120 °	50.00 Hz
U1	63.00 V	0 °	50.00 Hz
U2	63.00 V	240 °	50.00 Hz
U3	63.00 V	120 °	50.00 Hz



Default: 0 ms

Ext Timer: 0.000 s | Voltage: 0.007 V AC | Current: 0.010 A AC

Navigation

The Prefault->Fault screen scenario includes two views to configure the conditions for Prefault and Fault parameters, respectively. For test mode the third view "Prefault->Fault" is selected.

Prefault-> Fault instrument buttons

Symbol	Description
	Prefault
	Fault + Time
	Prefault-Fault

Prefault view

- 1] Press the Prefault button to enter prefault view.



- 2] Select generators to be active and configure the voltage, current, phase and frequency parameters for each.
- 3] Set the time duration for how long to generate the Prefault state before SVRERKER 900 is automatically entering Fault state.
- 4] Press the  button if you want to activate the selected generators.

Note *The time duration condition is not valid, during this operation, and the generators can only be turned off by pushing the  button.*

Fault view

- 1] Press the FAULT+TIME button from the Prefault view, for the FAULT view screen. Here you can configure the parameters for the Fault state.



- 1] Select generators to be active and configure the voltage, current, phase and frequency parameters for each.
- 2] Configure the two timing parameters; the max time duration, for how long the Fault state will be generated and the off delay duration, which is the time period after the test object has triggered and until the output generation will be switched off.

Note *The max time duration condition is not valid during this operation, and the generators can only be turned off by pressing the  button, or by a trip from the test object. After the configured off delay time period the trip time is displayed on the screen.*

Automatic Prefault->Fault button

The third view "Prefault->Fault" is selected for the test mode. No values can be changed.



- 1] Press the  button to generate the Prefault condition for the set time duration and then change to Fault state.

The device will generate the Fault state until any of the following conditions are met:

- A] Maximum configured time duration has time-out
- B] Test object trips
- C] You press the  button

Note For each condition, the configured off delay time period is added before turning off generation.

The phase angle graph

On both screen views, Prefault and Fault, a phase diagram is displayed which illustrates I and U phase relationship for both states.

- 1] Press the graph to make it full screen.
- 2] Tap on full screen to minimize.

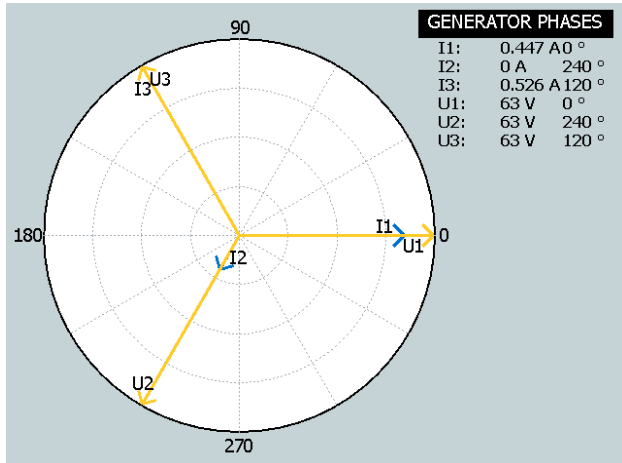

4.5 Ramping instrument

The Ramp instrument is selected from the Home menu using the button

The Ramping test is very similar to the Prefault->Fault scenario. The difference is that you can configure a ramping condition, between the Prefault and the Fault state. This includes the step-changes in voltage, current, phase and/or frequency, as well as the ramping time duration.

Ramping view

I1	0.000 A	0 °	50.00 Hz
I2	0.000 A	240 °	50.00 Hz
I3	0.000 A	120 °	50.00 Hz
U1	63.00 V	0 °	50.00 Hz
U2	63.00 V	240 °	50.00 Hz
U3	63.00 V	120 °	50.00 Hz

0 VDC BI TRIP 0.000 s

Ext Timer 0.000 s Voltage 0.006 V AC Current 0.010 A AC

Navigation

Ramping includes four views; Start, Speed, Stop and Test mode view. You can navigate back and forth between these four views, by pressing the respective buttons.

Ramping instrument buttons

Symbol	Description
	Set ramp start
	Set ramp speed
	Set ramp stop
	Test mode (initiate a ramp test) No values can be changed

- 1] Select the generators to be active and configure the voltage, current, phase and frequency parameters for each.
- 2] Press to set the preferred start values in the parameter table. The pre-fault time can also be set here.
- 3] Press to set ramp speed. For the phase angle, the direction is indicated by setting "-" or not in the keypad menu.
- 4] Press to set stop values.
- 5] To initiate a ramp sequence, press

Start a ramp test

- 1] In the views "Set ramp start" and "Test mode" you can start generating by pressing



In "Set ramp start" generating can only be stopped by pressing



For "Test mode view" the output generating is turned off if any of the following conditions are met.

- A] Pressing the  button
- B] The ramping state has reached any end condition
- C] The test object trips

If test object trips, the measured trip time is displayed on screen.

Speed and Stop ramping set views

The Speed and Stop ramping views are only a configuration views, no output generation can be activated from these screens. Here you configure the ramping conditions. This includes the ramping step-changes for the voltage level, current level, phase angle and frequency.

Note *You have to configure the ramping parameters before activating the test. If the settings for ramping have been set wrong, e.g. start and stop settings are in conflict it is not possible to start a ramp test.*

The phase angle graph

The phasor diagram in ramping instrument shows the I and U phase relationship both for prefault state as well as the end condition state after ramping.

- 1] Press the graph to make it full screen.
- 2] Tap on full screen to minimize.

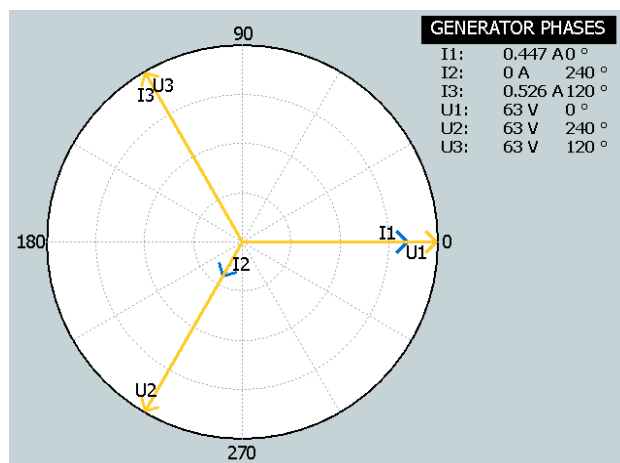

4.6 Sequencer instrument











The sequencer instrument is used to test several conditions in a system, e.g. the automatic recloser. The sequencer instrument is selected from the Home menu using the button .

Navigation

There are 16 programmable states in the sequence instrument. In each state you can set values for voltage, current, phase angles, frequency.



The following configurations/changes can be made in each state.

Sequencer instrument buttons

Symbol	Description
	Copy or delete state
	Go to first / last state
	Go forward / backward between states
	Activates BI and Stop on condition. Make settings for selected state
<input type="text" value="250 ms"/>	Set the time for selected state.
	Set the end of sequence
	Make voltage/contact sensing configuration for the binary input
	Stop condition for selected state
	Set contact condition for the binary inputs
	Set position for binary outputs
	Copy and paste selected state
	Delete state

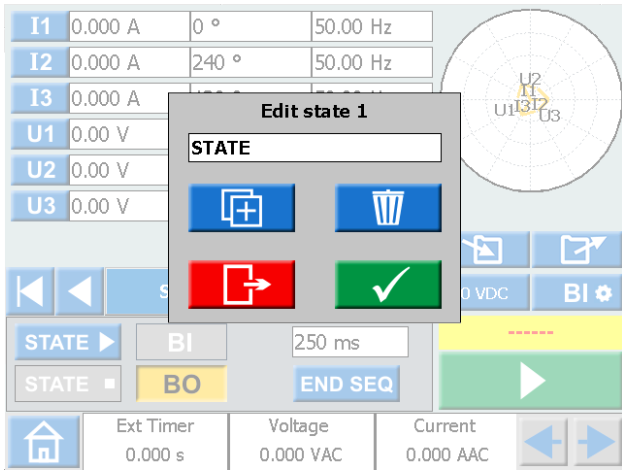
- 1] Press  to copy or delete a state.
- 2] You can give the state a new name, for example "Prefault 1(16)".



- 3] Press  to make a copy of the selected state. It will be inserted as a new state. New configuration for that state can be done. Press  to delete the state.
- 4] Press to set the time (milliseconds).
- 5] Press  button to configure, voltage/contact sensing, Hysteresis and Debounce.

Note *When this is changed in any "state" it will automatically be valid for all states.*

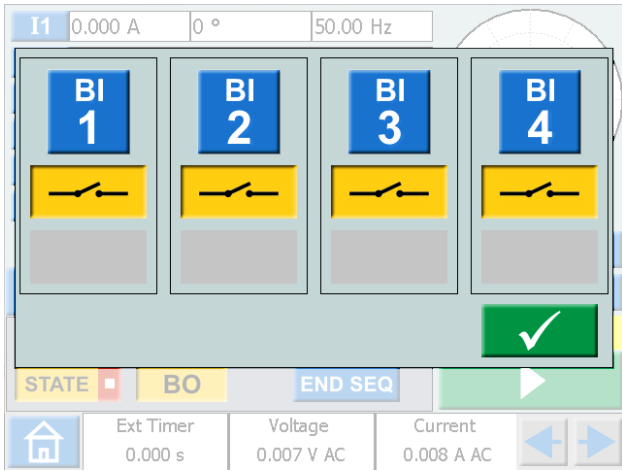

- 6] Select binary inputs and make the settings. Voltage or contact sense. Hysteresis voltage (BI 1 only), see page 23. Debounce filter, see page 23

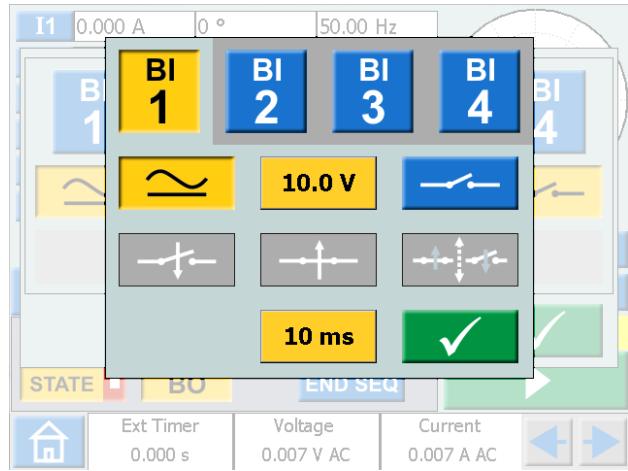

- 7] Press  button to activate the and 

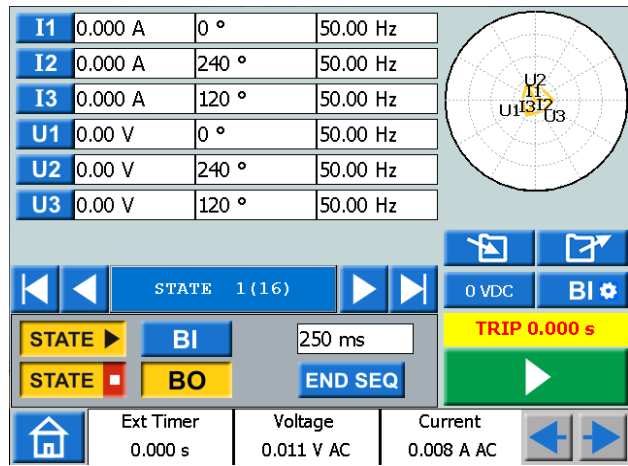

- 8] Press 
- 9] Select binary inputs and make the settings.

Note *For setting BI, see explanation in BI menu, page 22*

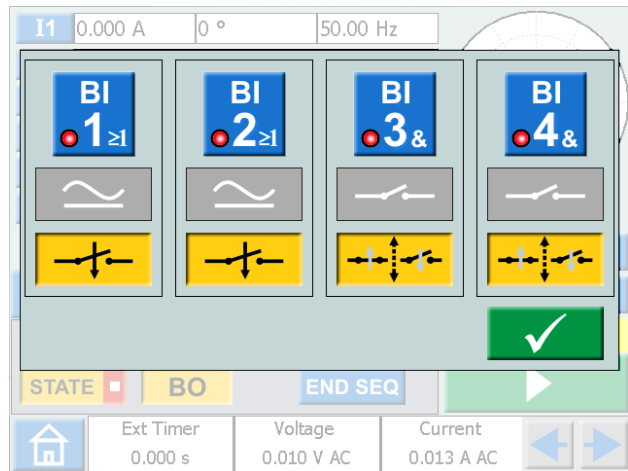

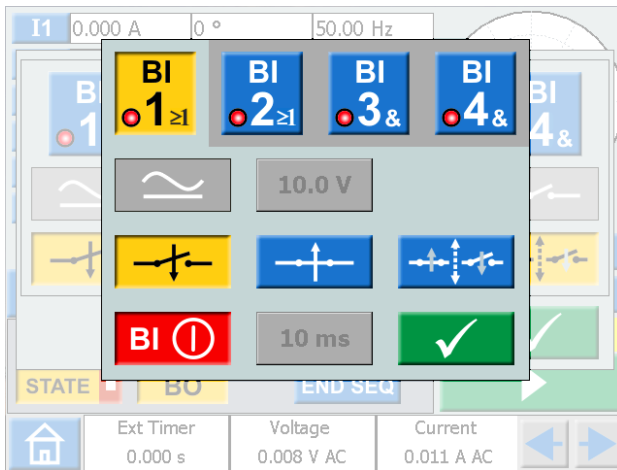

- 10] Press **STATE** to set a stop condition for the selected state.
The sequence is terminated when a trip signal is detected in that particular state
- 11] Press **END SEQ** to set the current state to be the last state in the sequence. It also stops to step further up to a higher numbered state.
- 12] Press **BO** to set the binary output position for each state, see "3.4 Binary Output" on page 11.
- 13] Start a sequence by pressing .
As soon as the condition for a state has been fulfilled the sequencer goes to next state, irrespective of set time (max time for each state).

The results are shown in new window when any of the following occurred:

- After stop on a trip signal
- The sequence is terminated with the stop button
- All the states have passed.

When the "condensed" view is selected, only the generators used are shown.

#	I1: A	°	Hz	BI	Time: ms	BO
1	1.000	0	50.00	1	739	1
2	2.000	0	50.00	1	132	1
3	3.000	0	50.00	1	1169	1
4	4.000	0	50.00	1	1077	1

Condensed

Ext Timer: 0.000 s | Voltage: 7.594 V AC | Current: 0.007 A AC

The check box "Condensed" is in bottom of the result window.

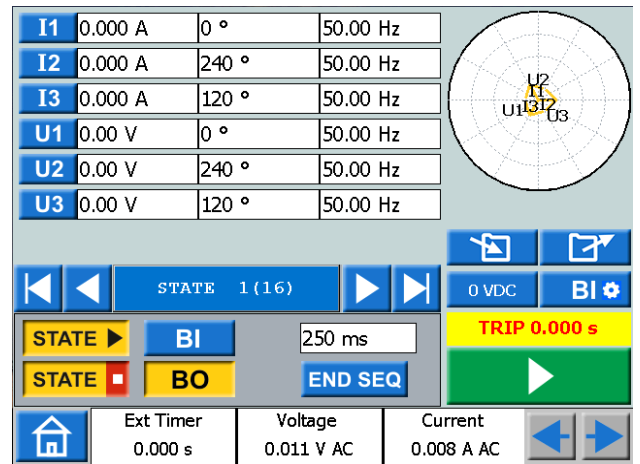

Note You can return to the result window by pressing the yellow or red field above the button.
When a test is saved the field is red.

Note The BO relay has a switching time at opening or closing of relay contact that is not compensated for. The switching time is normally around 5 to 7 ms. When doing a sequence the BO relay will be switched directly after the change of sequence state. Meaning that the switching relay time extends this transition between the states with this 5 to 7 ms.

Note The AND condition for the BI inputs is valid only within for each specific state.

4.7 CT magnetization instrument

In the lid is an accessory placed that is to be used for the CT magnetization instrument.



The CT magnetization instrument is used to determine the knee point voltage of a current transformer.

In CT-mode SVERKER 900 can generate up to 900 V by connecting the four voltage generators in series and 300 V by connecting the four voltage in parallel.

The magnetization can be made manual or automatic or as a combination, to start in manual mode and then switch to auto for the demagnetization part. This method is good to use for the first test on a CT.



CTM-box to be used in serial with volt/lampere meter and CT.

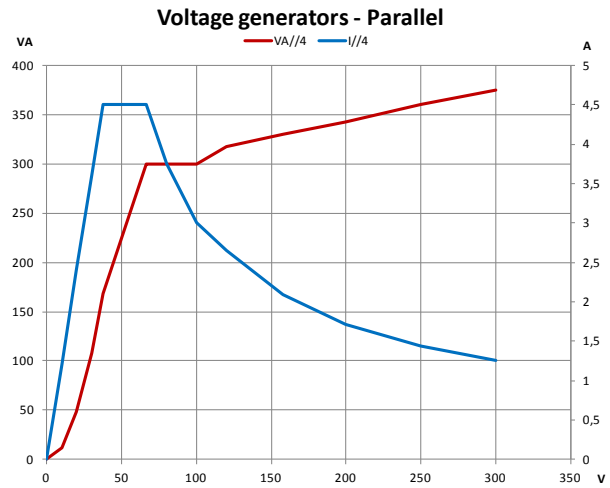
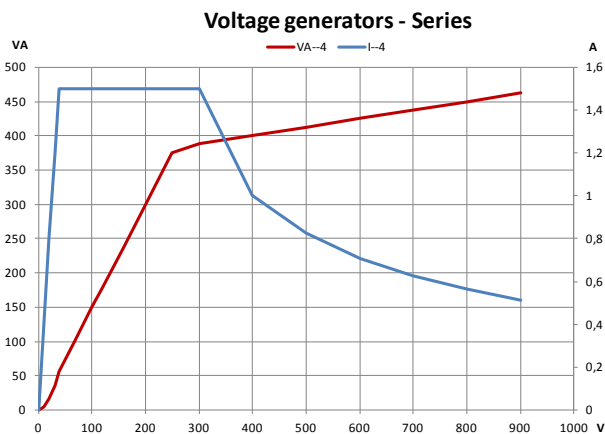



CT magnetization instrument buttons

Symbol	Description
	Set maximum voltage Possible in all test modes
	Set maximum current Possible in all test modes
	Manual mode for the test
	Automatic mode for the test

Set-up

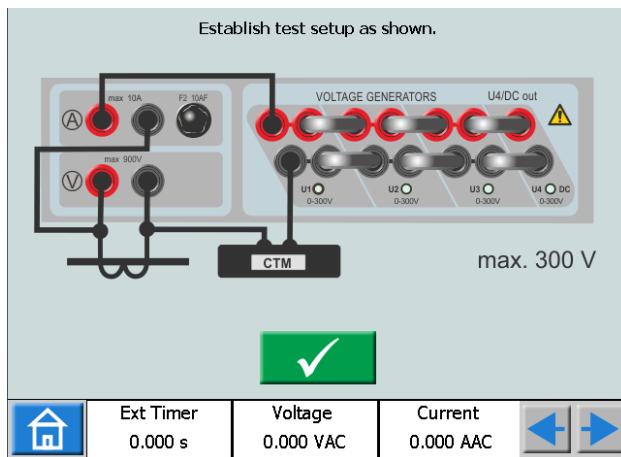
- From the Home menu you press to configure the voltage generators. Two configurations are possible to use, 4 generators in parallel (300 V) or serial (900 V) mode, depending on desired output voltage and power. See adjacent diagrams for guidance.
- From the Home menu you press Select IEC or IEEE(45° or 30°) standard.
- From the Home menu you press the CT instrument button When the CT instrument is opened, a picture shows how to connect the voltage output to the CT.



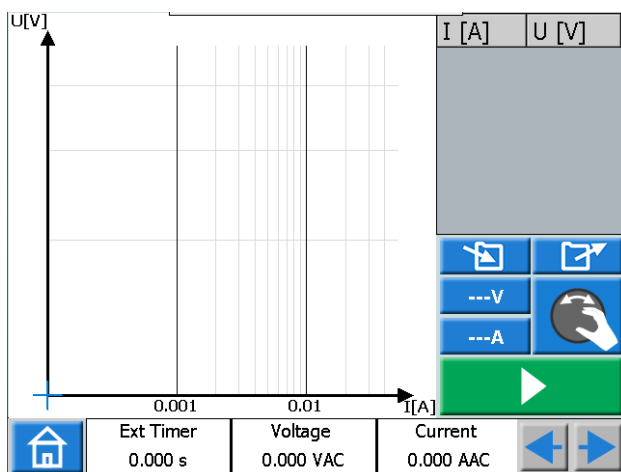

- 4) Press  to confirm the connection. The screen will show as below.



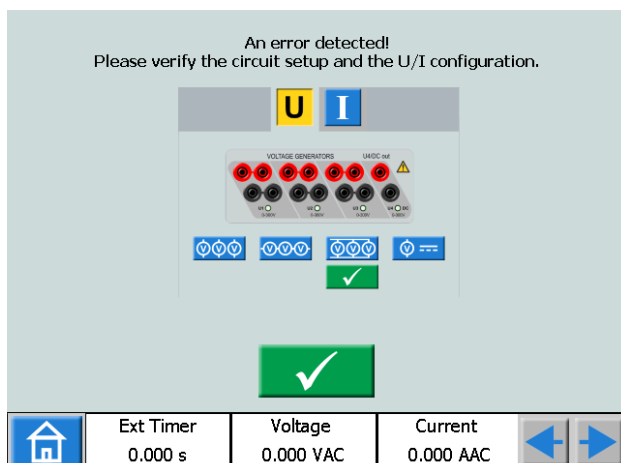

Note *If the screen will show as below you must correct your configuration, see step 1 above.*

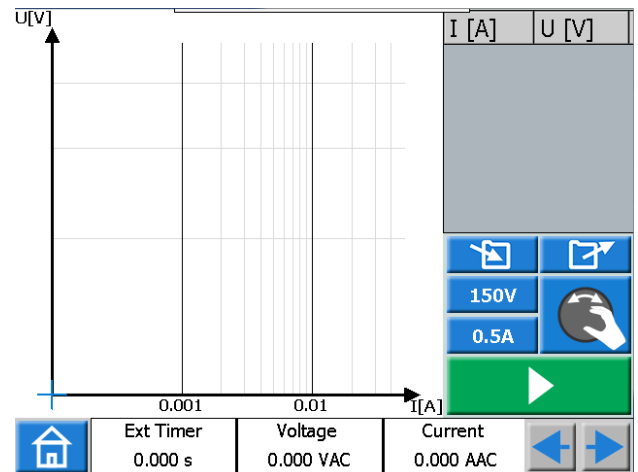

Manual test

- 1) The default mode is manual mode . If not, press the button.
- 2) You can set limits for maximal voltage and current if needed. Press the buttons  or  and make the settings.



- 3) Start test by pressing  and then slowly turn the control knob clockwise until knee point is reached.

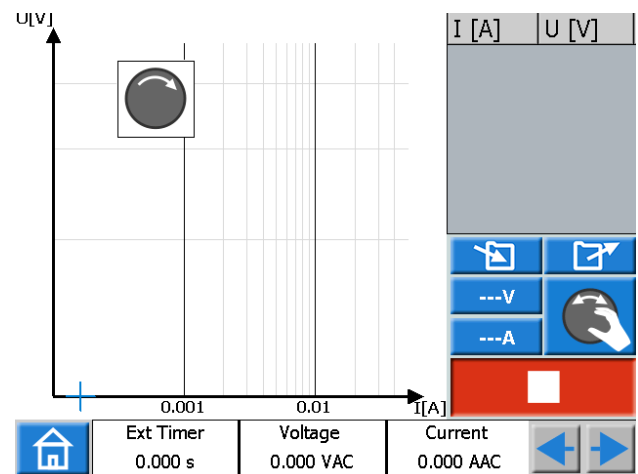

Note *If the control knob is not turned a knob symbol will pop-up in upper left corner to indicate that turning should be done.*

Note *The magnetization can be stopped manually by turning the control knob back to zero.*

- 4) When the arrow on the control knob symbol changes direction, from clockwise to anti-clockwise, you should start the demagnetization by turning the control knob anticlockwise.

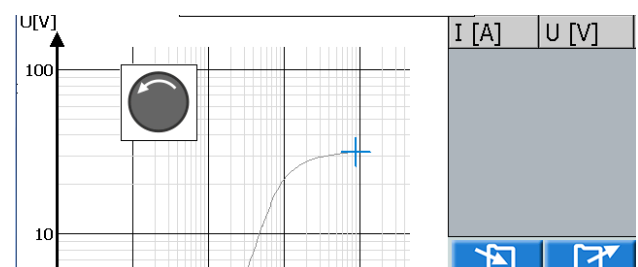

- 5) Press the control knob repeatedly to plot the graph during the demagnetization.

The graph is plotted and the knee point with plotting values presented.

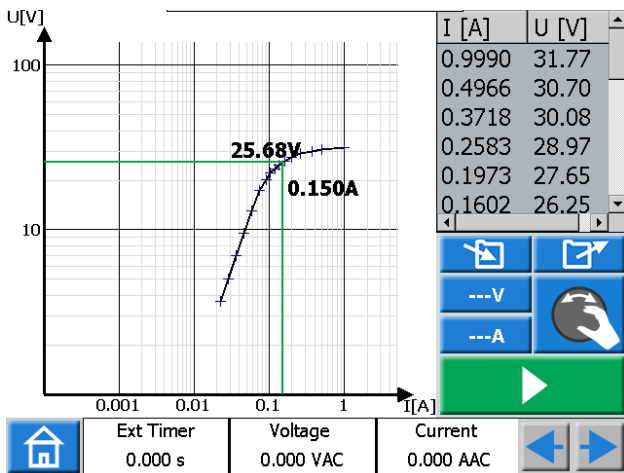

- 6] Press the diagram to get full screen. Press again to return.
- 7] The test is completed and ready to save.

Manual/auto test

- 1] Start in the same way as for the manual test
- 2] When the arrow on the control knob symbol changes direction, from clockwise to anti-clockwise, press 

- 3] The demagnetization and plotting will be made automatically.

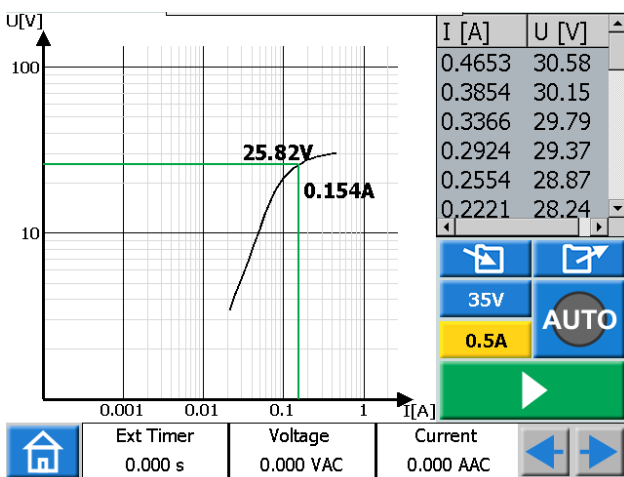

- 4] The test is completed and ready to save.

Auto test

- 1] Press the  button to position 

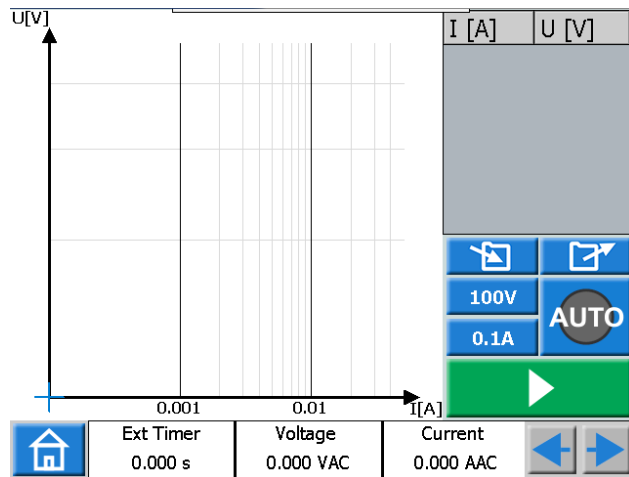

- 2] Start test by pressing 
- 3] Demagnetization of the CT is automatically done when the knee point is reached. The graph will be automatically plotted and the knee point with plotting values presented.
- 4] The test is completed and ready to save.

Demagnetization

If the demagnetization is interrupted by e.g. pressing the  button a warning message will be displayed.

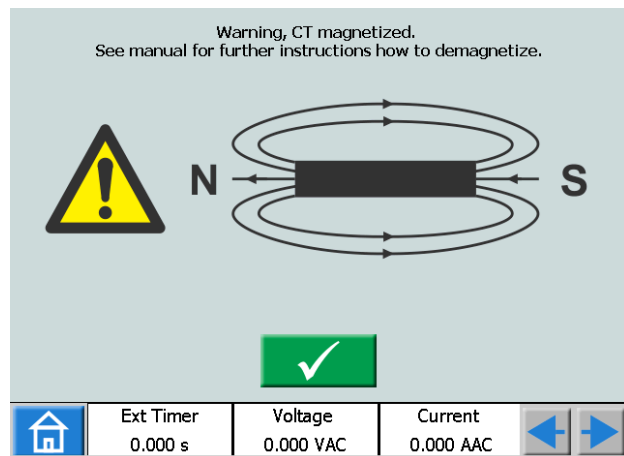

Important

Make a couple of magnetization and demagnetization sequences manually before you continue with the test.

4.8 Test file management

From all instruments you can save any test results or test configuration in SVERKER 900 persistent storage or to an external USB memory.

When you save a test the first time you will have to select where to save the test.











When a second test is to be saved, it will by default be saved in the previous used test file.



Tip!

In the active windows you can turn the Control knob to browse lists and press the knob to select an item.

Buttons in Test file management

Symbol	Description
	Save test
	Open test
	Quick save
	View
	Edit
	Save to USB
	Open USB
	Open test file library
	Create new file
	Delete test file



Save a test



1] Press  to save a test.

If no test file are selected the window below will be shown: "SELECT TEST FILE FOR STORAGE".

SELECT TEST FILE FOR STORAGE						
Date	Station	Position	Type	Serial...	#	
2014-03-25	megger...	table	schne...	ty12	2	
2014-03-31	Danderyd	H1	Test		1	

- 2] Select file by pressing on desired row in table and press  To save in a new file, see point 5 below.

STORE TEST	
Station: danderyd	
Position: stor trax trafo	
Type: ct	
Serialnr.: 12345	
Test no: 5	
Name	<input type="text"/>
Comments	<input type="text"/>
[MAIN, OFF Settings: I1: 0A, 0°, 50Hz I2: 0A, 240°, 50Hz I3: 0A, 120°, 50Hz U1: 63V, 0°, 50Hz U2: 63V, 240°, 50Hz	
	

- 3] Type in the name of the test and add comments.
If you want to select another file to save the test, press 
- 4] Press  to save.
- 5] To create a new file, press 

SELECT TEST FILE FOR STORAGE						
Date	Station	Position	Type	Serial...	#	
2014-03-25	megger...	table	schne...	ty12	2	
2014-03-31	Danderyd	H1	Test		1	

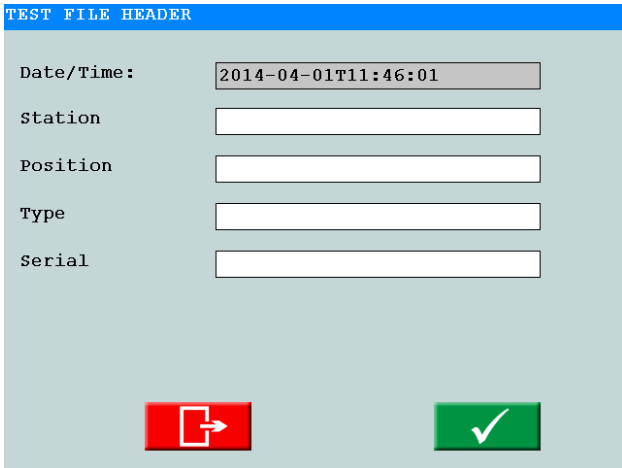





- 6] Enter the label names.
- 7] Press  to confirm.

Quick save

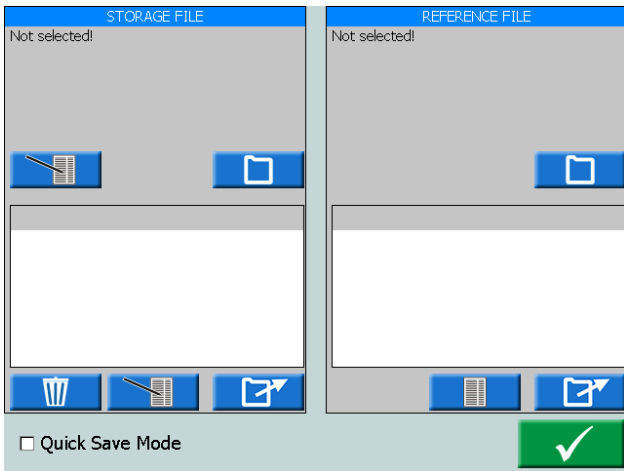
Note *By using this option you can save additional tests in the same file. The first test in the file cannot be in quick save mode.*

- 1] Press  and press the check box "Quick save mode".



- 2] Press 
- 3] After each following test press  to save.
The test are not named but placed in the same file as the first test.
- 4] To leave Quick save mode, press  and press, to uncheck, the check box "Quick save mode".



View and reuse test files

- 1] Press 

From the "STORAGE FILE" and "REFERENCE FILE" all the test files can be selected and opened. Selected test will be opened in the instrument that is running.



Note *Only tests made for the instrument that is running can be opened.*

Storage file

- 1] In the "STORAGE FILE" window, press  "SELECT TEST FILE FOR STORAGE" is opened.
- 2] In "STORAGE FILE" window, press the upper button  to edit the "Test File Header".
- 3] In "STORAGE FILE" window, press the lower  button to edit test name and comments.

Reference file

In the "REFERENCE FILE" window you can view and open a test for reuse.

- 1] In the "REFERENCE FILE" window, press  "SELECT REFERENCE TEST FILE" window is opened.
- 2] Select the test file you want to reuse for your test.
- 3] Press 



In the "REFERENCE FILE" window a list of the tests will be shown and in the left window "PREVIEW" you can see the test settings.

- 4] Select the test you want to reuse and press 





The test settings will be uploaded to the running instrument.

Transfer files to PC

Transfer files to PC for further handling by saving them to an USB stick.

- 1] Press  for the Home menu.
- 2] Press  to open the "Test file manager".

TEST FILE MANAGEMENT						
	Date	Station	Position	Type	Serial...	#
<input type="checkbox"/>	2014-03-31	Danderyd	H1	Test		1
<input type="checkbox"/>	2014-03-31	Danderyd	H1	Test		0
<input type="checkbox"/>	2014-04-01	Danderyd	H1	Test		0

- 3] Here one or more files can be selected and copied to an USB stick.
- 4] Select file by scrolling the list and press the Control knob, or press on check box to select a test file.
- 5] Press the  button to save.

Note: *The USB buttons are enabled when a USB stick is connected to SVERKER 900.*

The button  opens an edit file menu for the label data.

The files are saved as ".csv" files in the root directory on the USB stick.

Selected test file can also be put to the waste bin.

The right most column shows how many tests are included for each test file.

The csv file can be opened on a PC by double clicking, or by associate the csv file to be opened in Excel or Word, or other program.

Copy test files from USB stick to SVERKER 900

- 1] Insert a USB stick to the SVERKER 900.
- 2] Click the  button.
The test files on the USB stick are shown and can be copied to SVERKER 900.

5 Troubleshooting and Error messages

Problem	Cause	Remedy
Outputs		
No current or voltage output	Channel disabled	Activate channel
	The thermal cut-out may have tripped due to an overload	Wait until the unit has cooled
No Binary output	Miniature circuit breaker F1 may have tripped	Check the miniature circuit breaker
Cannot set U4/ DC amplitude, grayed out	Voltage generators are set in parallel or serial mode(U1 – U4)	Set generators to work separately
BINARY INPUTS		
Binary Inputs do not operate	Wrong setting in BI menu	Check the BI menu, voltage/contact sense open or closing
	Debounce filter time is inappropriate	Set the debounce filter time to be appropriate
Harmonics		
Cannot set Harmonics	SVERKER is in wrong mode	Go to system configuration menu and select "Advanced mode" ON
Voltmeter / Ammeter		
Built in ammeter malfunction	Fuse F2 faulty	Replace F2
Ammeter / voltmeter shows incorrect values	Wrong settings	Check settings AC/ DC and ranges
File handling		
Cannot copy files to USB memory	Test file is not checked in "Test file management"	Check the test files in the "Test file management"
	USB memory not inserted to SVERKER or corrupted USB memory	Verify the USB memory
EXTRA TIMER		
The Extra Timer value is not saved to test file	The "Save test" button is not marked in the Extra Timer setup menu	Mark the "Save test" button

Problem	Cause	Remedy
START and STOP does not react on input signals.	Wrong setting for the debounce time	Check the debounce time setting
	Wrong setting for the START/STOP	Check the START/ STOP settings menu, voltage/contact sense open or closing.
Error messages		
CAN address error / CAN BUS ERROR	Internal communication error	Restart unit, if same error persist contact Megger representative
DISTORTION	Measured output signal differs too much from the desired output signal	Check the output load
FAN #1 FAULTY	Big upper fan faulty	Check fan and if error persists contact Megger representative
FAN #2 FAULTY	Big lower fan faulty	Check fan and if error persists contact Megger representative
ILLEGAL OPERATION	Internal firmware error	Close menu and check setup of SVERKER and connections
INPUT POWER	The desired operation cannot be performed due to too high output power	Decrease the output settings or load
LOAD LIMIT	The output load has been exceeded	Decrease the load
Unknown! Unknown0 Unknown8	Internal communication error	Restart unit, if same error persist contact Megger representative
ZC CALCULATION	Internal firmware error	Restart unit, if same error persist contact Megger representative
SVERKER 900 unexpected error: 0x0	Internal fault	Restart unit, if same error persist contact Megger representative

Problem	Cause	Remedy
Please power cycle	Internal fault	Restart unit, if same error persist contact Megger representative
OPEN CURRENT CIRCUIT	The current output circuit has been disconnected	Check connections
VOLTAGE SHORT CIRCUIT	The voltage output is short circuit connected	Check connections

6 Specifications

Specifications SVERKER 900

Specifications are valid for resistive load, at 170-240 voltage supply and ambient temperature $+25^{\circ}\text{C} \pm 3^{\circ}\text{C}$, ($77^{\circ}\text{F} \pm 5.4^{\circ}\text{F}$) after 30 minutes warm up time and in the frequency range 10 Hz to 70 Hz. All hardware data are for full scale values. Specifications are subject to change without notice.

Environment

Application field For use in high-voltage substations and industrial environments.

Temperature

Operating 0°C to $+50^{\circ}\text{C}$ (32°F to $+122^{\circ}\text{F}$)
Storage & transport -40°C to $+70^{\circ}\text{C}$ (-40°F to $+158^{\circ}\text{F}$)
Humidity 5% – 95% RH, non-condensing
Altitude (operational) 2000 m (6500 ft)
Shock and vibration IEC 60068-2-27
Vibration IEC 60068-2-6

CE-marking

EMC IEC61326-1
LVD IEC61010-1:2010

General

Mains input 100 - 240 V AC, 50 / 60 Hz
Current consumption 10 A (max)
Power consumption 1800 VA (max)
Dimensions
Instrument 350 x 270 x 220 mm (13.8" x 10.6" x 8.7")
Flight case with wheels 615 x 295 x 500 mm (24.2" x 11.6" x 19.7")
Flight case 620 x 295 x 365 mm (24.4" x 11.6" x 14.4")
Weight 14.9 kg (32.8 lbs) Instrument only
 29.0 kg (64 lbs) with accessories and flight case (with wheels, GD-00185)
 23.9 kg (52.7 lbs) with accessories and flight case (GD-00182)
Display 5.7" LCD Touch screen
Available languages English, French, German, Spanish, Swedish

Measurement section

BINARY INPUTS 1, 2, 3, 4 and EXTERNAL TIMER Start/Stop

Number 6
Type Dry or wet contacts max, 240V AC or 340VDC
Galvanic Isolation Galvanically separated
Max measuring time 35 minutes
Debounce filter Settable, 0 to 999 ms
BINARY INPUT 1 Adjustable threshold and hysteresis

Timer

Range	Inaccuracy
0 – 50 ms	≤ 1 ms
50 – 500 ms	≤ 2 ms
> 500 ms	$\leq 1\%$

Resolution 1 ms

Voltmeter

Measurement method: AC true RMS, DC mean value

Insulation 900 V, 1273 V_{peak}
Input rating 900 V

Inaccuracy

Ranges DC

0-1 V $\pm 0.5\%$ of reading + 3 mV
0-10 V $\pm 0.5\%$ of reading + 7 mV
0-100 V $\pm 0.5\%$ of reading + 30 mV
0-900 V $\pm 0.5\%$ of reading + 300 mV

Ranges AC

0-1 V $\pm 1\%$ of reading + 5 mV
0-10 V $\pm 1\%$ of reading + 10 mV
0-100 V $\pm 1\%$ of reading + 50 mV
0-900 V $\pm 1\%$ of reading + 300 mV

Resolution

1 mV

Frequency

Range 10 Hz – 600 Hz
Inaccuracy $< 0.01\%$
Resolution < 10 mHz

Ammeter

Measurement method: AC true RMS, DC mean value

Inaccuracy

Ranges DC

0-200 mA $\pm 0.5\%$ of reading + 2 mA
0-1.5 A $\pm 0.5\%$ of reading + 3 mA
0-10 A $\pm 0.5\%$ of reading + 10 mA

Ranges AC

0-200 mA $\pm 1\%$ of reading + 2 mA
0-1.5 A $\pm 1\%$ of reading + 3 mA
0-10 A $\pm 1\%$ of reading + 20 mA

Resolution

1 mA

Frequency

Range 10 Hz – 600 Hz
Inaccuracy $< 0.01\%$
Resolution < 10 mHz

Extra measurements

Power factor and phase angle measurements

	Ranges	Resolution	Inaccuracy
Power factor $\cos\varphi$	-0.01 (cap) to 1 to +0.01 (ind)	< 0.01	< 0.04
Phase angle ($^{\circ}$) ¹⁾	0° - 360°	$< 0.1^{\circ}$	$< 0.8^{\circ}$

Impedance and power measurement

AC $Z(\Omega)$, $R(\Omega)$, $X(\Omega)$, $P(W)$, $S(VA)$, $Q(VAR)$

DC $R(\Omega)$, $P(W)$

Range Up to 999 kX (X=unit)

¹⁾ Valid with current > 1 A and voltage > 10 V

BINARY OUTPUTS

Insulation 250 V AC
Current 1 A (max)
Voltage 250 V AC or 120 V DC

Generation section

VOLTAGE GENERATORS

Voltage outputs U1, U2, U3 and U4/DC out

All voltage sources/generators are galvanically separated from each other and from ground.

Floating common return is made by using jumper connectors

Range

4-phase AC	4 x 300 V
4-channel DC	4 x 300 V

Power

4-phase AC	4 x 125 VA (max)
4-channel DC	4 x 125 W (max)

Inaccuracy 0.03% range + 0.05% of reading

Distortion(THD+N)¹⁾ < 0.14% typical (0.25% max)

Resolution 10 mV

Phase

Angle range	0° - 360°
Inaccuracy ²⁾	< 0.5° (at 50-60 Hz)
Resolution	< 1°

Frequency

Range	10 Hz - 600 Hz
Inaccuracy ²⁾	< 0.03 % (45 Hz - 66 Hz)
Resolution	< 10 mHz

- 1) THD+N: Values at 50/60 Hz, 200-300 V, $\geq 1500 \Omega$ load. Measurement band with 22-22 kHz.
- 2) The specification is valid for resistive load $> 2000 \Omega$ for voltage output separately U1, U2, U3 and U4/DC out.

Voltage generators in single-phase mode, AC or DC			
4 Voltage generators in parallel: U1 // U2 // U3 // U4	Voltage	Power (max)	Current (max)
	300 V	375 VA	1.2 A
	100 V	300 VA	3.0 A
	67 V	300 VA	4.5 A
External load: min. 7 Ω			
3 Voltage generators in parallel: U1 // U2 // U3	Voltage	Power (max)	Current (max)
	300 V	312 VA	1.0 A
	100 V	250 VA	2.5 A
	67 V	250 VA	3.7 A
External load: min. 9 Ω			
Voltage generators - Parallel and separate 			
4 Voltage generators in series: U1 - U2 - U3 - U4	Voltage	Power (max)	Current (max)
	900 V	450 VA	0.5 A
	400 V	360 VA	0.9 A
	268 V	350 VA	1.3 A
External load: min. 100 Ω			

3 Voltage generators in series: U1 - U2 - U3	Voltage	Power (max)	Current (max)
	900 V	350 VA	0.4 A
	300 V	280 VA	0.9 A
	200 V	275 VA	1.4 A
External load: min. 75 Ω			

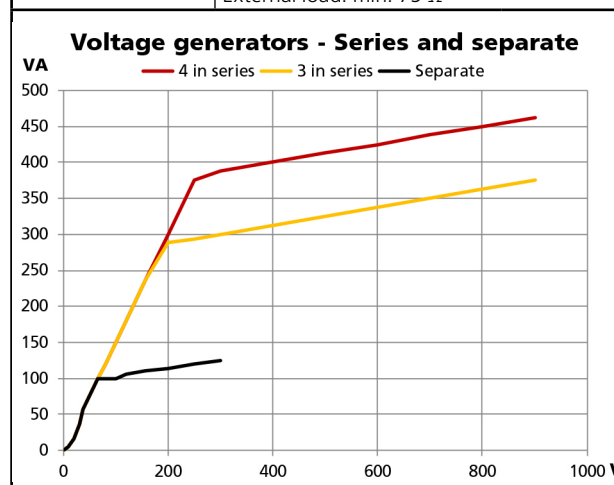

CURRENT GENERATORS

Current outputs I1, I2 and I3

All current generators are galvanically separated from each other and from ground

Floating common return, is made by using jumper connectors

Range

3-phase AC	3 x 35 A
	At least 15 repetitions: 10 s ON and 20 s OFF
3-channel DC	3 x 35 A
	At least 15 repetitions: 10 s ON and 20 s OFF
3-phase AC	3 x 20 A continuous
3-channel DC	3 x 17 A continuous

Power

3-phase AC	3 x 250 VA (max)
3-channel DC	3 x 250 W (max)

Inaccuracy < 0.5 % of reading, in range 0.5 A - 35 A
< 8 mA in range 0 A - 0.5 A

Distortion(THD+N)¹⁾ < 0.13% typical (0.25% max)

Resolution 1 mA

Compliance voltage ≤ 50 Vrms

Phase

Angle range	0° - 360°
Inaccuracy ²⁾	< 0.2° (50 - 60 Hz)
Resolution	< 1°

Frequency

Range	10 Hz - 600 Hz
Inaccuracy ²⁾	< 0.03 % (45 - 66 Hz)
Resolution	< 10 mHz

1) THD+N: Values at 50/60 Hz, 10-30 A, 0.5 VA load. Measurement band with 22-22 kHz.

2) The specification is valid for resistive load $\leq 0.08 \Omega$ and $I \geq 0.15$ A.

Current generators in single-phase mode, AC or DC			
Current generators in parallel: I1 // I2// I3			
Current	Power (max)	Voltage (max)	Duty cycle
15 A	750 VA	50 V	Continuous
45 A	750 VA	16.5 V	Continuous
50 A	750 VA	14.7 V	Continuous
60 A	600 VA	10 V	Continuous (AC)
105 A	300 VA	2.8 V	At least 15 repetitions: 10 s ON and 20 s OFF

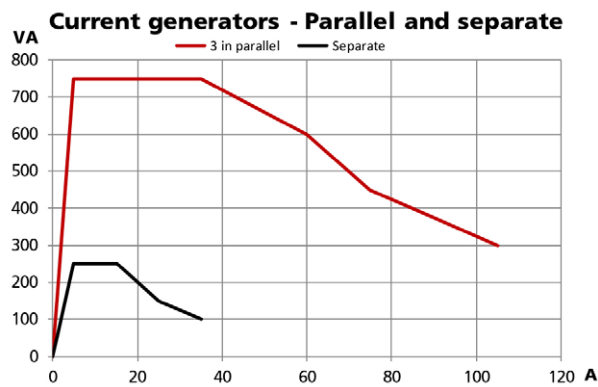

Current generators in series: I1 – I2 – I3			
Current (max)	Power (max)	Voltage (max)	Duty cycle
10 A	625 VA	140 V	Continuous

External load : min. 5 Ω

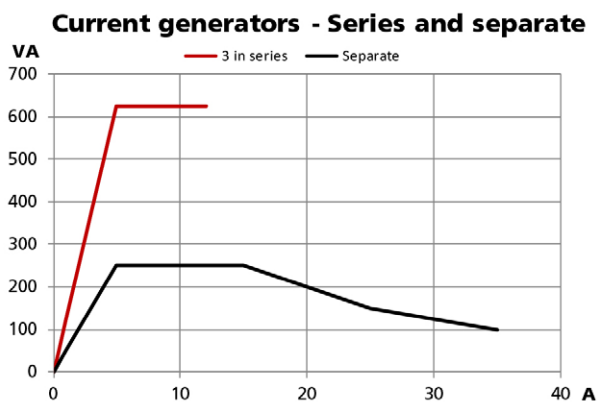

Optional accessories

Low current adapters LCA1 and LCA2

Dimensions

- LCA1 110 x 64 x 28 mm (4.3" x 2.5" x 1.1")
- LCA2 110 x 64 x 44 mm (4.3" x 2.5" x 1.7")

Weight 0.2 kg (0.4 lbs)

Input 5 A (max)

Index

A	
A-meter.....	15
AND condition.....	23
Application or removal of AC or DC voltage ..	11
Auto test	32
B	
Balance.....	21
Binary Inputs.....	11,22
Binary Output.....	11
C	
Copy test files from USB	35
CT magnetization instrument.....	30
Current generators	12
D	
DC supply	13
Debounce filter	23
Demagnetization.....	32
Drop-off.....	22
Dry contacts Close	11
Dry contacts Open.....	11
E	
Equals.....	21
Error messages	36
Ethernet port.....	17
External timer	14
F	
Firmware upgrade	16
G	
Generator settings	20
H	
Harmonics	24
Home menu	18
Hysteresis voltage	24
I	
Instrument description	10
L	
Local interface	18
Low current generation.....	17
M	
Main instrument.....	20
Make BI settings.....	23
Manual test.....	31
N	
Numerical keypad.....	21
O	
OFF+TIME.....	21
ON+TIME	21
OR condition.....	23
P	
Panels.....	10
Pick-up.....	22
Prefault->Fault instrument.....	25
Q	
Quick save.....	34
R	
Ramping instrument	26
Reference file	34
Reuse test files	34
S	
Safety	6
Safety instructions	6
Save a test.....	33
Sequencer instrument	27
Service and support.....	9
Special settings available for BI1.....	23
Specifications	38
Storage file	34
Symbols on the instrument.....	6
System configuration	19
T	
Test file management	33
The phase angle graph.....	26
Training courses	9
Transfer files to PC.....	34
Troubleshooting.....	36
U	
Unpack system.....	8
USB port.....	16

V

View and reuse test files.....	34
V-meter	15
Voltage generators	13

Your "One Stop" Source for all your electrical test equipment needs

- Battery Test Equipment
- Cable Fault Locating Equipment
- Circuit Breaker Test Equipment
- Data Communications Test Equipment
- Fiber Optic Test Equipment
- Ground Resistance Test Equipment
- Insulation Power Factor (C&DF) Test Equipment
- Insulation Resistance Test Equipment
- Line Testing Equipment
- Low Resistance Ohmmeters
- Motor & Phase Rotation Test Equipment
- Multimeters
- Oil Test Equipment
- Portable Appliance & Tool Testers
- Power Quality Instruments
- Recloser Test Equipment
- Relay Test Equipment
- T1 Network Test Equipment
- Tachometers & Speed Measuring Instruments
- TDR Test Equipment
- Transformer Test Equipment
- Transmission Impairment Test Equipment
- Watthour Meter Test Equipment
- STATES® Terminal Blocks & Test Switches
- Professional Hands-On Technical and Safety Training Programs

Megger is a leading global manufacturer and supplier of test and measurement instruments used within the electric power, building wiring and telecommunication industries.

With research, engineering and manufacturing facilities in the USA, UK, Germany and Sweden, combined with sales and technical support in most countries, Megger is uniquely placed to meet the needs of its customers worldwide.

Megger is certified according to ISO 9001 and 14001. Megger is a registered trademark.

Megger Group Limited
UNITED KINGDOM
Dover, Kent CT17 9EN
ENGLAND

- | | |
|----------------------|------------------------|
| ■ AUSTRALIA | ■ POLAND |
| ■ BULGARIA | ■ ROMANIA |
| ■ CANADA | ■ RUSSIA |
| ■ CZECH REPUBLIC | ■ SINGAPORE |
| ■ CHINA | ■ SLOVAK REPUBLIC |
| ■ FRANCE | ■ SOUTH AFRICA |
| ■ GERMANY | ■ SPAIN |
| ■ HUNGARY | ■ SWEDEN |
| ■ INDIA | ■ SWITZERLAND |
| ■ INDONESIA | ■ TAIWAN |
| ■ KINGDOM OF BAHRAIN | ■ THAILAND |
| ■ KOREA | ■ UNITED ARAB EMIRATES |
| ■ MALAYSIA | ■ USA |
| ■ PAKISTAN | ■ VIETNAM |
| ■ PHILIPPINES | |



Megger

WWW.MEGGER.COM

Postal address:
Megger Sweden AB
Box 724
SE-182 17 DANDERYD
SWEDEN

Visiting address:
Megger Sweden AB
Rinkebyvägen 19
SE-182 36 DANDERYD
SWEDEN

T +46 8 510 195 00 seinfo@megger.com
F +46 8 510 195 95 www.megger.com