



USER MANUAL

KPG 25 kV

Edition: October 2010

Kilovolt Prueftechnik Chemnitz GmbH
Annaberger Straße 73
09111 Chemnitz
Germany

Tel: +49 / 371 / 53 032 - 10
Fax: +49 / 371 / 53 032 - 11
E-Mail: info@kilovolt.biz

CHAPTER 1

General

CHAPTER 2

Technical description

CHAPTER 3

Preparation for use

CHAPTER 4

Operating instructions

CHAPTER 5

Care, maintenance
and repair

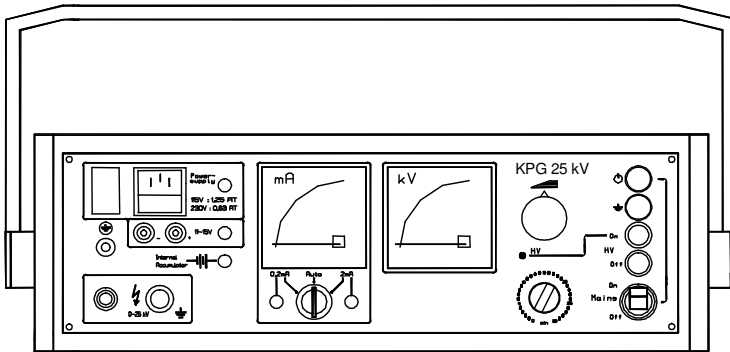

KPG 25 kV

CONTENTS

1	GENERAL	3
1.1	Safety instructions	3
1.2	Indications used in the description.....	5
2	TECHNICAL DESCRIPTION.....	9
2.1	Description of the set.....	9
2.1.1	Set version	9
2.1.2	Scope of supply	9
2.1.3	Use of the set.....	10
2.2	Design of the set.....	11
2.3	Function	12
2.4	Specifications	13
3	PREPARATION FOR USE.....	17
3.1	Operating requirements.....	17
3.2	Power supply.....	18
3.2.1	Internal rechargeable battery	18
3.2.2	Mains.....	18
3.2.3	External battery	19
3.2.4	Maintenance procedure (internal battery).....	19
3.3	Connecting the test equipment.....	20

4	OPERATING INSTRUCTIONS	25
4.1	Controls and displays	25
4.2	Operating procedure	27
4.2.1	Performing measurements	27
4.2.2	Ending testing	28
4.2.3	Safety measures	29
5	CARE, MAINTENANCE AND REPAIR.....	33

CHAPTER 1

GERNERAL

1 GENERAL

The KPG 25 kV is a generator of high direct voltages.

The insulation of cables, electrical plant and plant components can be tested for electric strength with this set. The insulation resistance of test objects can be determined by measuring current and voltage using integrated measuring instruments.

Thanks to its small size and low weight, the KPG 25 kV is portable and can be used directly on site. The clear arrangement of controls and displays makes the set comfortable to handle.

The set has an integrated rechargeable battery.

A special protective ground circuit ensures a high level of safety.

1.1 Safety instructions

All persons involved in the transport, installation, operation, maintenance and repair of this system must have read this user manual carefully.

The system and its accessories are in accordance with the current state of safety technology at the time of delivery. Owing to the work processes involved, however, there may be parts of the system and its peripherals which cannot be given optimum protection without an unreasonable reduction in function and usability.

The following safety instructions must be complied with.

GENERAL INSTRUCTIONS

Work on this system and its peripherals must only be performed by qualified and/or trained staff. Other persons must be kept away.

This user manual must be available for the supervisory, operating and maintenance staff to refer to.

Improper use may endanger life and limb, the system and connected equipment, as well as the efficient functioning of the system.

Always use correct tools in perfect condition.

Checks must be made to ensure that the relevant safety regulations are being complied with.

Only operate the system if it is in technically perfect condition.

No non-original parts may be used for the system and its peripherals, as the necessary safety will not be guaranteed. No mode of working which detracts from the safety of the system must be used.

The user is under an obligation to report any changes in the system to the supervisor responsible without delay.

ELECTROTECHNICAL INSTRUCTIONS

The system and all additional equipment must be connected properly.

The relevant DIN and VDE regulations must be complied with.

Maintenance work must only be carried out when the system is switched off (dead) and then only by qualified and/or trained staff.

1.2 INDICATIONS USED IN THE DESCRIPTION

Important instructions concerning personal protection, work safety and technical safety are indicated as follows:

WARNING: Warning indicates work and operating procedures which must be complied with in full to exclude the possibility of persons being put at risk. This includes instructions concerning particular dangers when handling the system.

ATTENTION: Attention indicates work and operating procedures which must be complied with in full to prevent the system/peripherals from being damaged or destroyed.

N.B.: N.B. indicates special technical requirements to which the user must pay particular attention when using the system.

CHAPTER 2

TECHNICAL DESCRIPTION

2 TECHNICAL DESCRIPTION

2.1 Description of the set

2.1.1 Set version

KPG 25 kV

2.1.2 Scope of supply

The scope of supply includes the following:

Item	Description
00001	KPG 25 kV with built in batteries and protective case
00002	Mains connecting cable
00003	Connecting cable for external battery
00004	Protective ground cable (green/yellow)
00005	Operation ground cable (black)
00006	HV- connecting cable (shielded) incl. clamp
00007	User manual /Service pack
00008	Packing

Table 2.1 Scope of supply

2.1.3 Use of the set

The KPG 25 kV is used for electrical testing of power cables and plant with direct voltage:

Areas of application include:

- Reclosing control after repairs and work on power cables, etc.
- Testing newly laid cables before initial use
- Testing disconnected cables
- Testing electrical equipment

CAUTION: Owing to the high voltages which occur, special safety measures are required. These are explained in later sections of the manual (see also chapter 1).

2.2 Design of the set

The compact KPG 25 kV is very portable thanks to its small size and low weight and can be used directly on-site. State-of-the-art technique and clearly designed operation panel for easy application. The control and display elements as well as the high-voltage outlet are arranged on the control panel.

A timer is provided for preselecting the testing time.

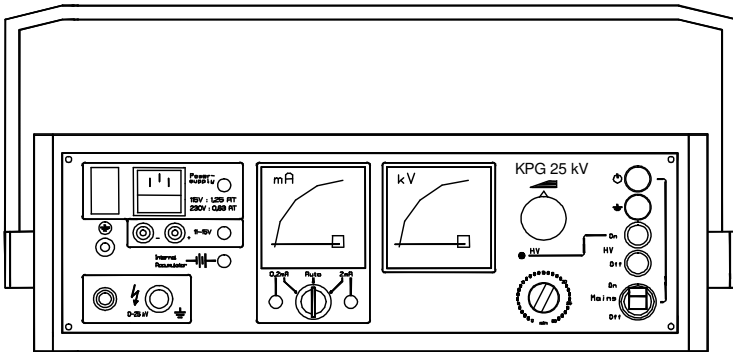

Fig. 2.1 High Voltage Tester KPG 25 kV

2.3 Function

Before the set can be used, the KPG 25 kV has to be grounded properly.

When the high-voltage adjuster is set to zero and the timer works, the test voltage can be switched on at the press of a button and increased continuously between 0 V and the nominal voltage.

The condition of the test object with regard to electric strength and insulation quality can be determined from the values for test voltage and leakage current displayed on the operation unit.

After testing, the object under test is discharged through the built-in discharging facility.

2.4 Specifications

Power supply	mains 115 or 230 V AC built-in rechargeable batteries external DC voltage 11-15 V
Power consumption	120 W max
DC output voltage	0...25 kV (negative polarity, infinitely variable)
Output current	1,5 mA
Short-circuit current	1,6 mA \pm 0,1 mA
Voltage measuring range	0 - 30 kV
Current measuring range	0 - 0,2 mA and 0 - 2 mA
Discharge energy	3000 J max.
Operating time at full load with built-in batteries	appr. 45 min
Operating temperature	-25°C to + 55 °C
Output	short circuit and open circuit proof
Weight incl. batteries	appr. 13,5 kg
Dimensions (WxHxD)	467 mm x 167 mm x 284 mm

CHAPTER 3

PREPARATION FOR USE

3 PREPARATION FOR USE

3.1 Operating requirements

The carrying handle of KPG 25 kV is designed for one-hand operating. After putting down the device carrying handle can be locked in 30°-steps by using a pull spring. Pulling on handle unfixes the lock.

WARNING: The clearance between the high-voltage unit and grounded or live parts as stipulated in DIN VDE 0104 must be complied with.

CAUTION: Warning notices reading

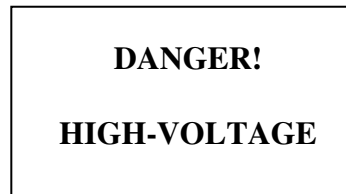

When the equipment is set up in the field, it must be placed outside the cable trench and protected against dirt and moisture.

The KPG 25 kV should be set up inside the cordon at a distance of appr. 3 m from the high-voltage, preferably at operating height.

3.2 Power supply

3.2.1 Internal rechargeable battery

The set has an integrated rechargeable battery. This supplies power when the "Mains" switch is actuated.

The mains and external battery, if connected, take precedence, however, and cause the internal battery to be switched off.

If the voltage is too low, the color of the LED [13] p. 25 changes from green to red. The high voltage will then be switched off after approximately 10 minutes.

3.2.2 Mains

If the set is connected to the mains, the external DC voltage and internal battery are switched off (signalled by the green LED [11] p. 25). Mains operation is accompanied by recharging / floating operation of the internal battery.

The set is switched on with the "Mains" switch, which is signalled by the white standby indicator [4] p. 25.

The KPG 25 kV has a monitoring circuit which switches the high voltage off if the voltage is too low.

The set remains connected to the mains even once the "Mains" switch has been turned off, allowing recharging / floating operation of the internal battery.

CAUTION: Take care of the voltage selector switch [1], p. 20!

3.2.3 External battery

The external DC voltage must be in the 11-15 V range. This is indicated by the green LED [12] p. 25. If the voltage is too low, the color changes to red. The high voltage will then be switched off after approximately 10 minutes.

3.2.4 Maintenance procedure (internal battery)

To charge the internal battery connect the mains supply to the KPG 25 kV (LED [11] p.25 lights up).

The 'Mains' switch doesn't have to be switched on.

It takes approx. 10 hours to fully charge the internal battery from low battery level.

The current is changed automatically between recharging / floatig operation of the internal accumulator.

3.3 Connecting the test equipment

The connecting cable is in the front of the carrying case.

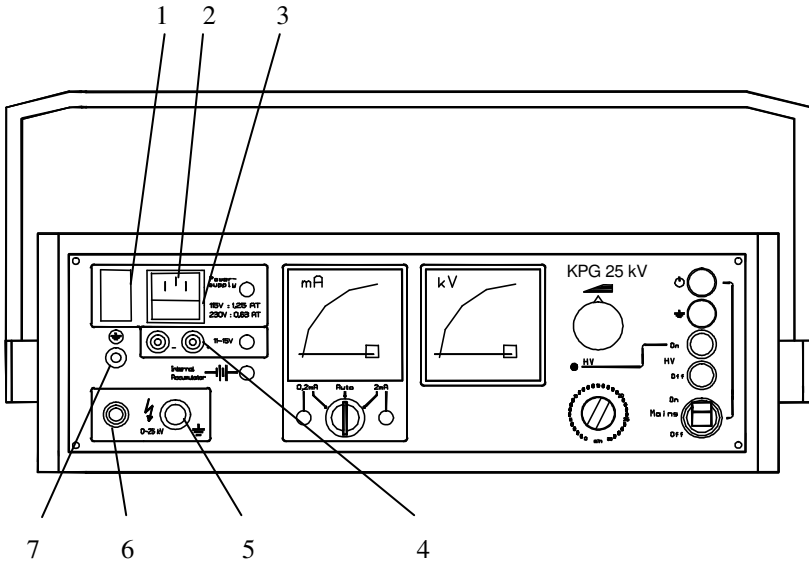

- 1 Voltage selector
- 2 Power supply
- 3 Fuse
- 4 Connector for external battery
- 5 Station ground
- 6 HV connector
- 7 Protective conductor terminal

Fig. 3.2 KPG 25 kV

Before the test equipment is connected, safe isolation from supply must be established and safeguarded in accordance with DIN VDE 0105. The requirements of DIN VDE 0104 and DIN VDE 0105

must be complied with. The test equipment should be connected in the following order:

1. Ground and short-circuit the conductor of the test object that is not going to be tested (connect to station ground or auxiliary ground point). In the case of ungrounded test objects, the test set can only be used if an auxiliary ground is provided.
2. Establish a conductive connection between the station/auxiliary ground and the ground terminal [5] of the KPG 25 kV.
3. In the case of mains operation the ground safety circuit checks whether the protective ground (protective conductor terminal [7]) and station ground have the same potential. The yellow lamp indicates that the potential is the same. If the lamp does not light up, the potential of the station ground must be checked and a connection established between the protective ground terminal and the station ground. The housing of the KPG 25 kV has the same potential as the protective ground terminal.
4. In the case of internal or external batteries establish a conductive connection between the protective conductor terminal [7] and station ground.
5. Connect the high-voltage terminal [6] to the test object.



Abb. 3.3 Example for connecting KPG 25 kV

CHAPTER 4

OPERATING INSTRUCTION

4 OPERATING INSTRUCTIONS

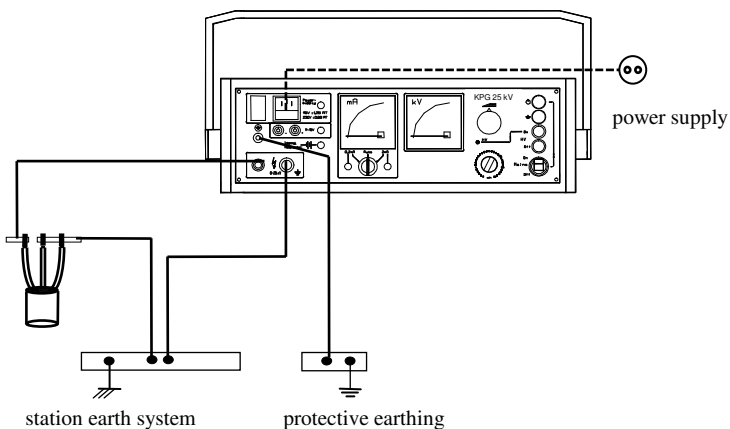
4.1 Controls and displays

The controls and displays needed to operate the KPG 25 kV are on the front of the operation unit.

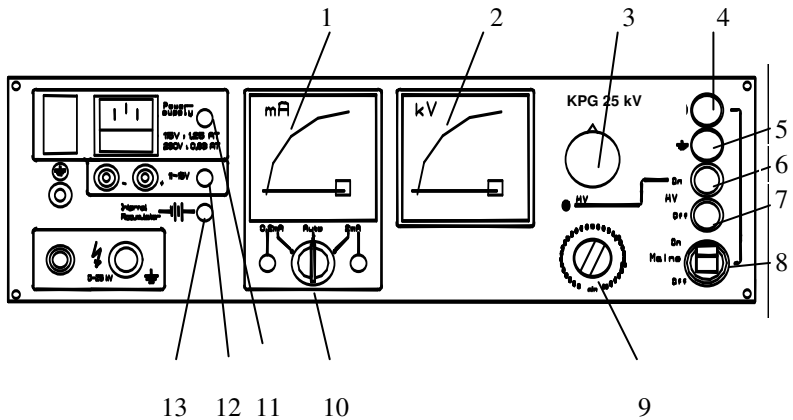

Fig. 4.1 Front of the KPG 25 kV

The following tables explain the controls:

Item	Description	Remarks
1	Ammeter	Displays the current flowing through the test object
2	Voltmeter	Displays the voltage connected to the test object
3	HV adjuster	Adjuster for the high-voltage with forced zero position
4	"Unit on" lamp	Lights up when the unit is switched on with the mains switch [8]

Table 4.1 Controls and displays (part 1)

Item	Description	Remarks
5	"Ground terminal" lamp (yellow)	Lights up when the KPG 25 kV is grounded properly
6	Illuminated "HV on" button (green)	Button for switching on the high voltage (lights up, when operational readiness)
7	Illuminated "HV off" button (red)	Illuminated button for switching off the high voltage (lights up when the high-voltage is switched on)
8	Mains switch	optional: key-switch
9	Timer	
10	"Current measuring range" selector switch	Switches between the current measuring ranges or 'AUTO'
11-13	LED's	for Power supply, internal batteries and external batteries

Table 4.1 Controls and displays (part 2)

4.2 OPERATING PROCEDURE

4.2.1 Performing measurements

When the mains switch is turned on, the white pilot lamp (Fig. 4.1 [4], p. 25) lights up. If the equipment is grounded properly, the yellow pilot lamp also lights up.

If this does not happen, the KPG 25 kV still has to be grounded (protective conductor terminal).

This pilot lamp [5] signals proper connection of the station and protective grounds independently of the high voltage being connected.

The equipment will only work when all three lamps are lit and the timer is in action.

The green "**HV on**" [6] button switches the high voltage on if the HV adjuster [3] in zero position at left stop (second switching operation, interlock, forced zero position).

HINWEIS: If you want to select testing times shorter than 5 min, turn the rotary knob of the timer first beyond the position "5" and then to the desired time.

The red illuminated "**HV off**" [7] button lights up at the same time, indicating that the "high voltage is switched on".

The test voltage can now be set by **slowly** turning the adjuster anticlockwise. While doing this, remember to follow the increase in voltage and current on the instruments.

The output current can be measured in two measuring ranges (0.2 mA, 2 mA), which can be set using a selector switch [10].

In the central switch position (Auto), the measuring range is changed automatically.

The relevant LED indicates the selected measuring range.

N.B.: The end stage of the KPG 25 kV is secured against thermal overload by a reverse voltage divider. In case of overload (e.g., short-circuit at the output), the output current is reduced to a value of about 0,5 mA.

4.2.2 Ending testing

Once testing is complete, turn the voltage down and switch the equipment off ("HV off" Fig. 4.1 p. 25 [7]).

When the test time expires, the high-voltage is switched off automatically by the timer and the discharge device is activated. The discharge process of the test object can be followed on the measuring instrument.

ATTENTION: After four discharge processes at a maximum, a break of about 30 minutes shall be made.

Once the displayed high-voltage reading has dropped to 0, the test object can be grounded and the KPG 25 kV disconnected.

Finally ground/short-circuit the test object itself.

WARNING: The high-voltage connector must not be plugged in / unplugged when live.

In an emergency, the high voltage must be switched off by a second operator pressing the red "HV off" button.

4.2.3 Safety measures

The set must only be operated by electricians in accordance with DIN VDE 1005. It must only be operated in areas which have been secured and/or cordoned off and marked in accordance with DIN VDE 0104 and DIN VDE 0105.

In an emergency, the high voltage must be switched off by a second operator pressing the red "HV off" button.

N.B.: Never put equipment with moisture condensation into operation.

Please also follow the safety instructions in chapter 1.

Reliable grounding of the KPG 25 kV is always necessary in addition to adequate protection against electric shock.

CAUTION: Care must be taken during testing that the far end is also reliably protected against electric shock.

Be aware that residual charges may still be present after discharge in the case of capacitive tests.

WARNING: Parallel cables may also still be charged after testing.

CHAPTER 5

CARE, MAINTENANCE AND REPAIR

5. CARE, MAINTENANCE AND REPAIR

The repair work which can be done on the KPG 25 kV by the user is limited to the replacement of fuses and lamps. Fuses, lamps and tools are included in the service kit.

The KPG 25 kV is test equipment and as such must be handled and looked after with care.

Moisture, external soiling, direct sunlight and ambient temperatures in excess of 55°C must be avoided.

The exchange of the internal accumulator has to be carried out by a service workshop.

Don't store the KPG 25 kV with empty battery!